



**FACSIMILE EQUIPMENT
SERVICE MANUAL**

**MODEL: MFC3100C/MFC580/
FAX1800C**

PREFACE

This publication is a Service Manual covering the specifications, construction, theory of operation, and maintenance of the Brother facsimile equipment. It includes information required for field troubleshooting and repair--disassembly, reassembly, and lubrication--so that service personnel will be able to understand equipment function, to rapidly repair the equipment and order any necessary spare parts.

To perform appropriate maintenance so that the facsimile equipment is always in best condition for the customer, the service personnel must adequately understand and apply this manual.

This manual is made up of six chapters and appendices.

CHAPTER 1 GENERAL DESCRIPTION

CHAPTER 2 INSTALLATION

CHAPTER 3 THEORY OF OPERATION

CHAPTER 4 DISASSEMBLY/REASSEMBLY AND LUBRICATION

CHAPTER 5 MAINTENANCE MODE

CHAPTER 6 ERROR INDICATION AND TROUBLESHOOTING

Appendix 1. EEPROM Customizing Codes

Appendix 2. Firmware Switches (WSW)

Appendix 3. Circuit Diagrams

This manual describes the models and their versions to be destined for major countries. The specifications and functions are subject to change depending upon each destination.

CHAPTER 1 GENERAL DESCRIPTION

CONTENTS

1.1 EQUIPMENT OUTLINE 1-1

 1.1.1 External Appearance and Weight 1-1

 1.1.2 Components 1-1

1.2 SPECIFICATIONS..... 1-2

1.1 EQUIPMENT OUTLINE

1.1.1 External Appearance and Weight

The figure below shows the equipment appearance and approximate dimensions.

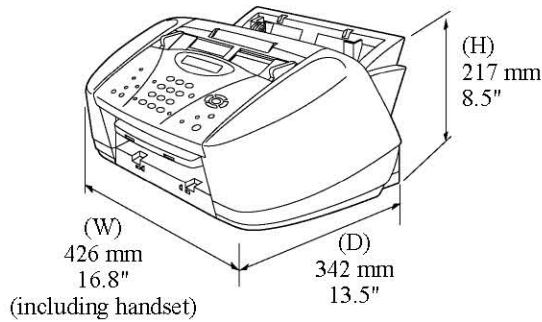

Weight:	Machine proper	Approx. 6.5 kg (14.3 lbs.)
	In package	Approx. 10.5 kg (23.2 lbs.)

1.1.2 Components

The equipment consists of the following major components:

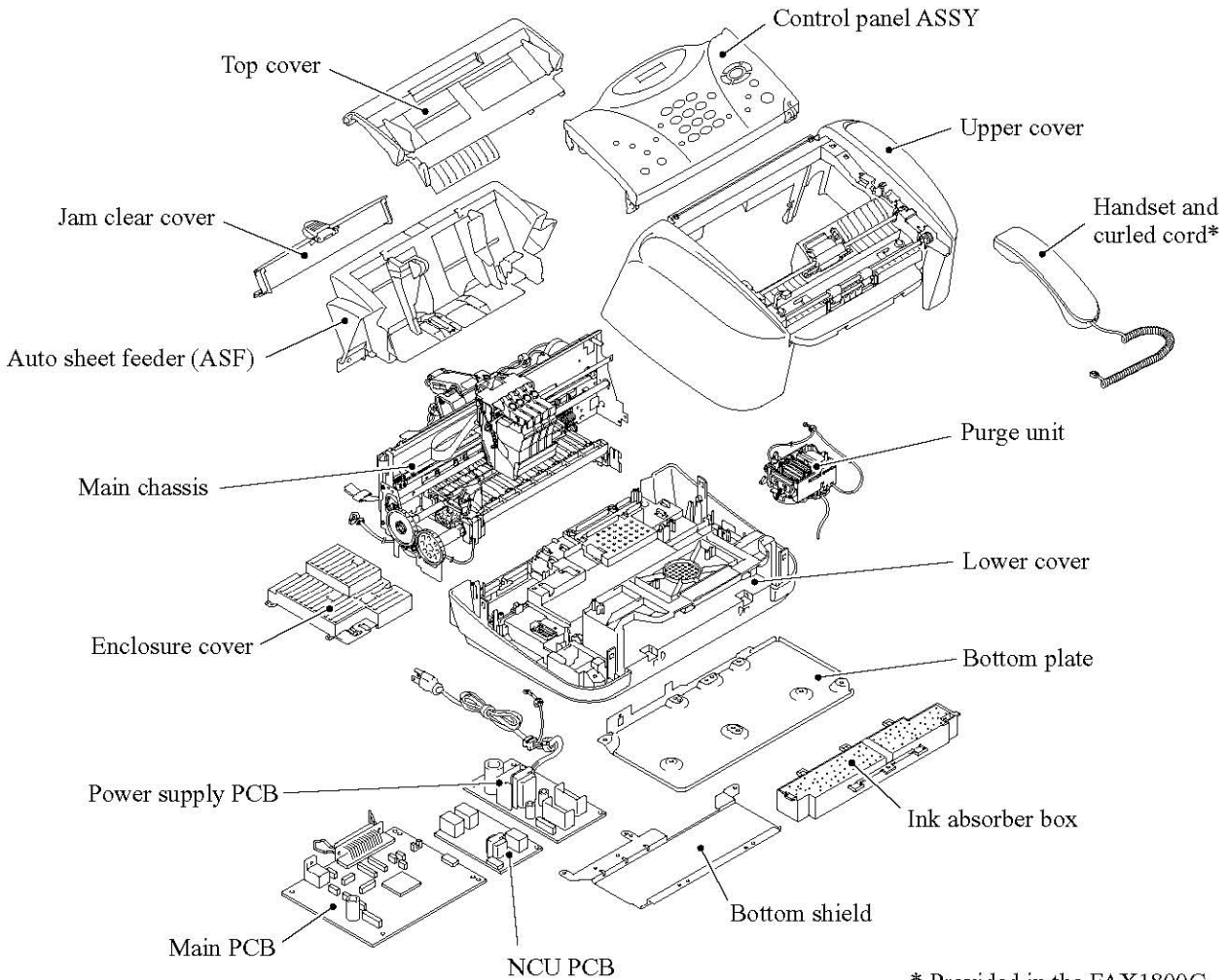

* Provided in the FAX1800C.

1.2 SPECIFICATIONS

Model Name	MFC 3100C
GENERAL	
Print Engine	Ink Jet (BH 2-head)
Modem Speed (bps)	14,400 (Fax)
Transmission Speed (sec.)	6 (Brother#1,MMR)
ITU-T Group	G3
Coding Method	MH/MR/MMR/JPEG
Document/Print Paper Width	3.5"-8.5"/3.5"-8.5"
Document/Print Paper Length	5.0"-14"/5.0"-14"
Print Paper Margin (upper, lower, left, right)	0.12, 0.43, 0.12, 0.12 inch (3,11, 3, 3 mm)
ADF (pages)	Up to 20
LCD Columns	16 characters
LCD Line	Single line
LCD Backlight	No
Backup Clock	Yes
Memory Backup	N/A
Memory Capacity (physical)	2MB (RAM)
Optional Memory	No
Dimensions w/o Carton (WxDxH)	16.8"x13.5"x8.5" (426x342x217 mm)
Dimensions w Carton (WxDxH)	20.4"x18.0"x14.8" (517x458x375 mm)
Weight w/o Carton	6.5kg/14.3lbs
Weight w Carton	10.5 kg/23.2lbs
Color	Gray 1495
Operating Environment Temperature	5 - 35 degrees Centigrade
Humidity	60% +-25%
Power Source	120VAC 50/60Hz
Power Consumption (Standby/Peak)	Under 7W/35W
On/Off Switch	No
TELEPHONE	
Handset	No
One-Touch Dial	No
Speed Dial	Max. 40
Speaker Phone	No
Chain Dialing	Yes
Caller ID	No
Call Waiting Caller ID	No
Distinctive Ringing	Yes
Hold/Mute Key	No
Hook Key	No
Power Failure Dialing	No
Speaker Volume	No
Ring Volume	Yes (2 steps + OFF)
Handset Volume	No
FAX	
Scan Speed (A4:Standard)	Approx. 5 sec./page (A4:standard)
Memory Transmission (Brother#1 Chart)	Yes (100:MMR)
Memory Transmission (ITU-T Chart)	Yes (85:MMR)
Out-of-Paper Reception (Brother #1 Chart)	Yes (100:MMR)
Out-of-Paper Reception (ITU-T Chart)	Yes (85:MMR)
Color FAX (Document Send/Receive)	Yes/Yes
Color FAX (Memory Send/Receive)	No/Yes
INTERFACE	
External TAD Interface	Yes
Host Interface (IEEE1284)	Yes
Host Interface (USB)	Yes
LAN Interface	No

Model Name	MFC 3100C
PRINTER	
Color/Mono	Color/Mono
Engine Type	Piezo Ink Jet (2-head BH: 75 nozzles/color)
Resolution (dpi)	1200x1200 /2400x1200 (Mono/Color)
Speed (ppm)	10/8 (Mono/Color: 600*150) 4/3.5 (Mono/Color: 600*300) 2/1.5 (Mono/Color: 600*600) 0.2/0.2 (Mono/Color: 1200*1200/2400*1200)
Paper Capacity (sheets)	100
Output Paper Capacity (sheets)	50
Standard Print Language	Windows GDI
Emulation	No
Resident Fonts	Yes
Fonts Disk Based	Yes
Paper Handling Size	LTR, LGL, A4, B5, A5, EXE, Post Card, Index Card
Manual Feed Slot	N/A
Other Paper Type	OHP, Envelopes
Sheet Weight (Paper Cassette) (Manual Slot)	64-120 g/m ² (17 - 32 lb) N/A
Printer Driver	Win95/98/98SE/Me/2000Professional/NT4.0/ MacOS 8.5-9.1
COPY	
Color/Mono	Color/Mono
Speed (cpm)	7/4 (Mono/Color)
Multi Copy(Stack)	Yes (B&W only) or Via PC
Multi Copy (Sort)	N/A or Via PC
Resolution (dpi)	Max. 1200x1200 (color)
SCANNER	
Color/Mono	Color/Mono
Resolution (dpi) (Physical)	CIS: 300x600 (Opt.)
Resolution (dpi) (Logical)	2400 (Int.)
Speed (ppm)	Max. 5sec
Gray Scale	256
TWAIN Compliant & Operating System	Win95/98/98SE/2000Professional/NT4.0/Me MacOS 8.6-9.1
PCI Scanner (Parallel/Serial)	Parallel/USB
ACCESSORY	
Cartridge	4 colors (each separate tank)
Life / Yield (Normal, 5% Coverage)	Black: 950, Color: 450

Model Name	MFC-580
GENERAL	
Print Engine	Ink Jet (BH 2-head)
Modem Speed (bps)	14,400 (Fax)
Transmission Speed (sec.)	6(Brother#1,MMR)
ITU-T Group	G3
Coding Method	MH/MR/MMR/JPEG
Document/Print Paper Width	90-216/90-216mm
Document/Print Paper Length	127-356/127-356mm
Print Paper Margin (upper, lower, left, right)	0.12, 0.43, 0.12, 0.12 inch (3,11, 3, 3 mm)
ADF (pages)	Up to 20
LCD COLUMNS	16 characters
LCD Line	1 Line
LCD Backlight	N/A
Backup Clock	Yes (1 hour)
Memory Backup	N/A
Memory Capacity (Physical)	2MB as spec.(Actually 8MB)
Optional Memory	No
Dimensions w/o Carton (WxDxH)	16.8"x13.5"x8.5" (426x342x217 mm)
Dimensions w Carton (WxDxH)	20.4"x18.0"x14.8" (517x458x375 mm)
Weight w/o Carton	6.5kg/14.3lbs
Weight w Carton	10.5 kg/23.2lbs
Color	Gray 1495
Operating Environment Temperature Humidity	5 - 35 degrees Centigrade 60% + -25%
Power Source	240VAC 50/60Hz
Power Consumption (Standby/Peak)	Under 6W/35W
On/Off Switch	No
TELEPHONE	
Handset	N/A
One-Touch Dial	N/A
Speed Dial	40
Speaker Phone	No
Chain Dialing	Yes
Caller ID	No
Call Waiting Caller ID	No
Distinctive Ringing	Yes (only for UK, Denmark)
Hold/Mute Key	No
Hook Key (Tel key)	Tel (for F/T switch)
Power Failure Dialing	No
Speaker Volume	No
Ring Volume	Yes (2 steps + OFF)
HandSet Volume	No
FAX	
Scan Speed (A4:Standard)	Approx. 5 sec./page (A4:standard)
Memory Transmission (Brother#1 Chart)	Yes (100:MMR)
Memory Transmission (ITU-T Chart)	Yes (85:MMR)
Out-of-Paper Reception (Brother #1 Chart)	Yes (100:MMR)
Out-of-Paper Reception (ITU-T Chart)	Yes (85:MMR)
Color FAX (Document Send/Receive)	Yes/Yes
Color FAX (Memory Send/Receive)	No/Yes
INTERFACE	
External TAD Interface	Yes
Host Interface (IEEE1284)	Yes
Host Interface (USB)	Yes
LAN Interface	No

Model Name	MFC-580
PRINTER	
Color/Mono	Color/Mono
Engine Type	Piezo Ink Jet (2-head BH: 75 nozzles/color)
Resolution (dpi)	1200x1200/2400x1200 (B&W/Color)
Speed(ppm)	10/8 (Mono/Color: 600*150) 4/3.5 (Mono/Color: 600*300) 2/1.5 (Mono/Color: 600*600) 0.2/0.2 (Mono/Color: 1200*1200/2400*1200)
Paper Capacity (sheets)	100
Output Paper Capacity (sheets)	50
Standard Print Language	Windows GDI
Emulation	N/A
Resident Fonts	Yes
Fonts Disk Based	Yes
Paper Handling Size	LTR, LGL, A4, B5, A5, EXE, Photo Card, Index Card
Manual Feed Slot	N/A
Other Paper Type	OHP, Envelopes
Sheet Weight (Paper Cassette) (Manual Slot)	64-105 g/m ² (17 - 28 lb) N/A
Printer Driver	Win95/98/98SE/Me/2000Professional/NT4.0/ MacOS 8.5-9.1
COPY	
Color/Mono	Color/Mono
Speed (ppm)	7/4 (Mono/Color)
Multi Copy (Stack)	Yes (B&W only) or Via PC
Multi Copy (Sort)	N/A or Via PC
Resolution (dpi)	Max. 1200x1200
SCANNER	
Color/Mono	Color/Mono
Resolution (dpi) (Physical)	CIS: 300x600 (Opt.)
Resolution (dpi) (Logical)	2400 (Int.)
Speed (ppm)	Max. 5sec
Gray Scale	256
TWAIN Compliant & Operating System	Win95/98/98SE/2000Professional/NT4.0/Me MacOS 8.6-9.1
PCI Scanner (Parallel/Serial)	Parallel/ USB
ACCESSORY	
Cartridge	4 colors (each separate tank)
Life / Yield (Draft, 5% Coverage)	Black: 950, Color: 450

Model Name	Fax 1800C
GENERAL	
Print Engine	Ink Jet (BH 2-head)
Modem Speed(bps)	33,600 (Fax)
Transmission Speed(sec.)	4 (Brother#1,MMR)
ITU-T Group	G3
Coding Method	MH/MR/MMR/JPEG
Document/Print Paper Width	3.5"-8.5"/3.5"-8.5"
Document/Print Paper Length	5.0"-14"/5.0"-14"
Print Paper Margin (upper, lower, left, right)	0.12, 0.43, 0.12, 0.12 inch (3,11, 3, 3 mm)
ADF(pages)	up to 20
LCD Columns	16 Characters
LCD Line	1 Line
LCD Back Light	No
Backup Clock	Yes
Memory Backup	N/A
Memory Capacity(Physical)	8MB (RAM)
Optional Memory	No
Dimensions w/o Carton (WxDxH)	19.1"x13.5"x8.5" (486x342x217 mm)
Dimensions w/ Carton (WxDxH)	22.6"x18.0"x14.8" (573x458x375 mm)
Weight w/o Carton	6.5 kg (14.3 lbs.)
Weight w/ Carton	9.2 kg (20.3 lbs.)
Color	Gray(1495)/Purple(6255)
Operating Environment Temperature	10 - 35 degrees Centigrade
Humidity	60% +-25%
Power Source	120 VAC 50/60Hz
Power Consumption (Standby/Peak)	under 7W/35W
On/Off Switch	No
TELEPHONE	
Handset	Yes
One-Touch Dial	12 (6x2)
Speed Dial	100
Speaker Phone	No
Caller ID	Yes
Distinctive Ringing	Yes
Hold/Mute Key	Yes
Hook Key (Tel key)	Yes
Power Failure Dialing	No
Speaker Volume	Yes
Ring Volume	Yes (2 steps + OFF)
Handset Volume	Yes
FAX	
Scan Speed (A4:Standard)	Approx. 8 sec./page (A4:standard)
Memory Transmission(Brother#1 Chart)	Yes (480:MMR)
Memory Transmission(ITU-T Chart)	Yes (400:MMR)
Out-of-Paper Reception (Brother #1 Chart)	Yes (480:MMR)
Out-of-Paper Reception (ITU-T Chart)	Yes (400:MMR)
Color FAX (Document Send/Receive)	Yes/Yes
Color FAX (Memory Send/Receive)	No/Yes
INTERFACE	
External TAD Interface	Yes
Host Interface (IEEE1284)	No
Host Interface (USB)	Yes
LAN Interface	No

Model Name	Fax 1800C
PRINTER	
Color/Mono	Color/Mono
Engine Type	Piezo Ink Jet (2 head BH: 75 nozzle/color)
Resolution(dpi)	1200x1200/2400x1200 (B&W/Color)
Speed(ppm)	10/8 (Mono/Color: 600*150) 4/3.5 (Mono/Color: 600*300) 2/1.5 (Mono/Color: 600*600) 0.2/0.2 (Mono/Color: 1200*1200/2400*1200)-
Paper Capacity(sheets)	100
Output Paper Capacity(sheets)	50
Standard Print Language	Windows GDI
Emulation	N/A
Resident Fonts	Yes
Fonts Disk Based	N/A
Paper Handling Size	LTR, LGL, A4, B5, A5, EXE, Post Card
Manual Feed Slot	N/A
Other Paper Type	OHP, Envelopes
Sheet Weight (Paper Cassette) (Manual Slot)	64-150 g/m ² (17 - 32 lb) N/A
Printer Driver	Win/98/98SE/Me/2000Professional/ MacOS 8.5/8.5.1/8.6/9.0/9.0.4/9.1
COPY	
Color/Mono	Color/Mono
Speed(ppm)	7/4 (Mono/Color)
Multi Copy(Stack)	Yes(B&W/Color)
Multi Copy(Sort)	N/A(B&W/Color)
Resolution(dpi)	Max. 1200x1200
SCANNER	
Color/Mono	Color/Mono
Resolution(dpi)(Physical)	CIS: 300x600(Opt.)
Resolution(dpi) (Logical)	N/A
Speed(ppm)	N/A
Gray Scale	N/A
TWAIN Compliant&Operating System	N/A
PCI Scanner (Parallel/Serial)	N/A
ACCESSORY	
Cartridge	4 colors (each separate tank)
Life / Yield (Draft, 5% Coverage)	BK: 950, CL: 450

CHAPTER 2 INSTALLATION

CONTENTS

2.1	INSTALLING THE UPDATE DATA TO THE FACSIMILE MACHINE.....	2-1
2.2	SETTING ID CODES TO FACSIMILE MACHINES	2-5
2.3	UPDATING HEAD PROPERTY INFO STORED IN THE FACSIMILE MACHINE	2-7

2.1 INSTALLING THE UPDATE DATA TO THE FACSIMILE MACHINE

If you want to update the current program stored in the flash ROM of the main PCB to the newer version or after you replace the main PCB, install the update program onto the flash ROM.

The program installation requires a PC/AT-compatible computer running MS-DOS, Windows 95, or Windows 98. For the FAX1800C, it requires Windows 98.

■ MFC3100C/MFC580

Connecting the facsimile machine to your PC

- (1) Make sure that your PC is turned off.
- (2) Make sure that the power cord of the facsimile machine is unplugged from a wall socket.
- (3) Connect the parallel interface cable to the parallel port on the back of the machine and secure it with the lock wires.
- (4) Connect the other end of the interface cable to the printer port of your PC and secure it with two screws.
- (5) While pressing the **5** key on the machine's control panel, plug the machine's power cord into a wall socket.
- (6) Check to see that the following pattern displays on the LCD. If it does not display, go back to step (2) above.



- (7) Turn on your PC.

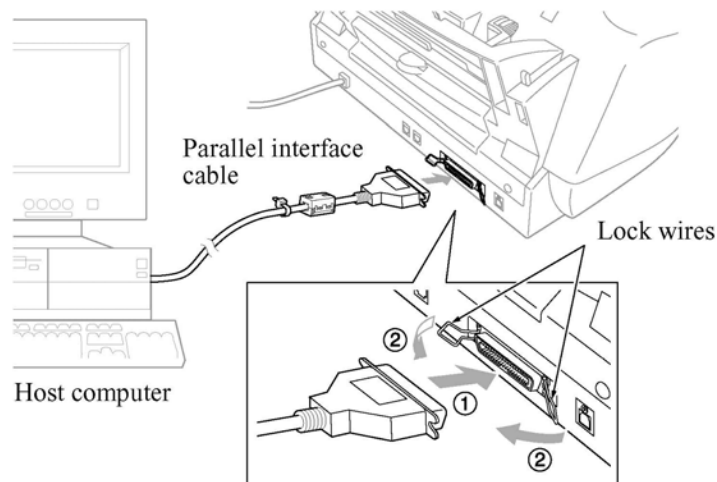

Installing the update data onto the flash ROM of the facsimile machine

NOTE: The following is an installation procedure example on a PC that is running Windows 98.

- (1) Copy the update data and transfer utility onto the desired directory of the hard disk.
e.g., C:\UPDATE
- (2) Click the Start button, point to Programs, and then click MS-DOS Prompt to open an MS-DOS window.
- (3) Type the drive letter where the update data and transfer utility are located. In the above example, type C:\ from the command line and press the **ENTER** key.

Then type CD UPDATE and press the **ENTER** key.

- (4) Check that your PC is connected with the facsimile machine correctly.
- (5) To start the transfer utility transmitting the update data to the flash ROM of the facsimile machine, type the following:

```
ICEN filename /b
```

Where *filename* is an update data file, e.g., 3100x.upd and 580xxxx.upd.

Then press the **ENTER** key.

During downloading, the machine beeps *intermittently*.

Upon completion of the downloading, the machine beeps *continuously*.

NOTE: If the facsimile machine cannot return to the standby state after completion of downloading, turn the power off and on.

■ FAX1800C

CAUTION: During installation, do not turn the power off, interrupt downloading, or download invalid data. If you do so, downloading will fail so that you need to replace the main PCB of the facsimile machine with a new one and download update data again. The failure PCB is no longer usable.

Connecting the facsimile machine to your PC

If you want to update the current program to the newer version:

- (1) Make sure that your PC is turned on.
- (2) Unplug the power cord of the facsimile machine from the wall socket.
- (3) While holding down the **Menu** key, plug the power cord of the facsimile machine into a wall socket.
- (4) Connect the USB cable to the USB port of your PC.
- (5) Connect the other end of the cable to the USB port on the back of the facsimile machine.

After you replace the main PCB:

- (1) Make sure that your PC is turned on.
- (2) Make sure that the power cord of the facsimile machine is unplugged from a wall socket.
- (3) Place the facsimile machine in the maintenance mode (refer to CHAPTER 5, Section 5.1), then connect the USB cable to the USB port on the back of the machine.
- (4) Connect the other end of the cable to the USB port of your PC.
- (5) Plug the power cord of the facsimile machine into a wall socket.

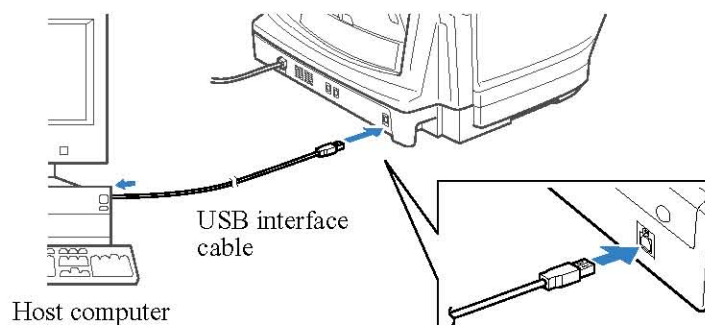

Installing the update data onto the flash ROM of the facsimile machine

NOTE: The following is an installation procedure example on a PC that is running Windows 98.

If you want to update the current program to the newer version:

- (1) Type 0, 3, and 2 on your PC.
- (2) Drag and drop the "Filedg32" from the Service Data Bank onto the desk top of your PC.
- (3) Drag and drop the 1800usaA.dat file onto the "Filedg32."

During downloading, the facsimile machine beeps *intermittently*.

Upon completion of the downloading, the facsimile machine beeps *continuously*.

- (4) Disconnect the USB interface cable from the facsimile machine and your PC.

NOTE: Do not place the facsimile machine in the maintenance mode when the USB interface cable is connected.

After you replace the main PCB:

- (1) Drag and drop the "Filedg32" from the Service Data Bank onto the desk top of your PC.
- (2) Drag and drop the 1800usaA.dat file onto the "Filedg32."

During downloading, the facsimile machine beeps *intermittently*.

Upon completion of the downloading, the facsimile machine beeps *continuously*.

- (3) Disconnect the USB interface cable from the facsimile machine and your PC.

NOTE: Do not place the facsimile machine in the maintenance mode when the USB interface cable is connected.

2.2 SETTING ID CODES TO FACSIMILE MACHINES

Brother facsimile machines are assigned unique ID codes (character strings) at the factory. If you replace the main PCB of the machine, the machine will lose its assigned ID code so that it will not be identified by the connected PC*.

You need to assign a unique ID code (character string) to the machine according to the procedure given here. For models covered by this manual, set serial numbers given to individual machines as ID codes.

(*ID codes are essential when more than one machine is connected to a single PC via USB.)

Connecting the facsimile machine to your PC (See the illustration on page 2-1.)

- (1) Make sure that your PC is turned off.
- (2) Make sure that the power cord of the facsimile machine is unplugged from a wall socket or other power source.
- (3) **MFC3100C/MFC580:** Connect the parallel interface cable to the parallel interface port on the back of the facsimile machine and secure it with the lock wires.
FAX1800C: Place the machine in the maintenance mode (refer to CHAPTER 5, Section 5.1), then connect the USB interface cable to the USB port on the back of the machine.
- (4) **MFC3100C/MFC580:** Connect the other end of the interface cable to the printer port of your PC.
FAX1800C: Connect the other end of the interface cable to the USB port of your PC.
- (5) While holding down the **Menu** key, plug the machine's power cord into a wall socket or other power source.
- (6) Turn on your PC.

Running the setup utility

- (1) On your PC, run the ID/head property setup utility (BRUSBSN.EXE). The following window will appear.

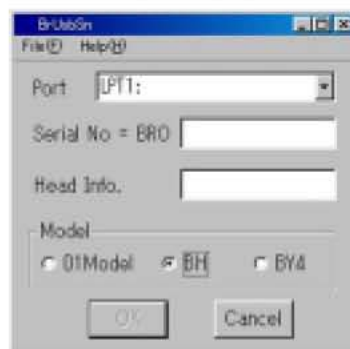

- (2) On the **Model** menu, click **BH**.
MFC3100C/MFC580: Click the **Port** down arrow to select the LPT1.

FAX1800C: Click the **Port** down arrow to select the USB port to which the FAX1800C is connected.

- (3) In the **Serial No = BRO** box, type the 9-digit serial number (e.g., G01012345) printed on the nameplate labeled to the back of the facsimile machine as an ID code. Then press the **Enter** key.

The setup utility will transmit the entered data from your PC to the facsimile machine and then it will terminate.

The facsimile machine will automatically return to the standby mode.

- (4) To check whether the entered character string (ID code) is correct, make the machine enter the maintenance mode (refer to CHAPTER 5, Section 5.1) and then press the **1** key twice (Subsection 5.3.5).

The facsimile machine will print out a Configuration List. At the right top of the list, "SER.#: BROXXXXXXXXXX" is printed.

- (5) Check that the character string entered in step (3) is printed in "XXXXXXXXXX."

If it is OK, press the **9** key twice to exit from the maintenance mode.

If something other than that is printed in XXXXXXXXXXXX, check the connection between the PC and facsimile machine and go back to step (1).

2.3 UPDATING HEAD PROPERTY INFO STORED IN THE FACSIMILE MACHINE

To keep the print quality, the controller optimizes the head drive strength, ink jet-out timing, and other drive conditions depending upon the electromechanical properties unique to individual print heads and ambient temperature. The head property information is stored in the EEPROM of the main PCB.

If you replace the print head unit and/or main PCB of the machine, then you need to update head property information according to the procedure given here.

TIP: The updating procedure given here uses a PC. For the updating procedure in the maintenance mode without using a PC, refer to CHAPTER 5, Subsection 5.3.14.

Connecting the facsimile machine to your PC (See the illustration on page 2-1.)

- (1) Make sure that your PC is turned off.
- (2) Make sure that the power cord of the facsimile machine is unplugged from a wall socket or other power source.
- (3) **MFC3100C/MFC580:** Connect the interface cable to the parallel interface port on the back of the facsimile machine and secure it with the lock wires.
FAX1800C: Place the machine in the maintenance mode (refer to CHAPTER 5, Section 5.1), then connect the USB interface cable to the USB port on the back of the machine.
- (4) **MFC3100C/MFC580:** Connect the other end of the interface cable to the printer port of your PC.
FAX1800C: Connect the other end of the interface cable to the USB port of your PC.
- (5) While holding down the **Menu** key, plug the machine's power cord into a wall socket or other power source.
- (6) Turn on your PC.

Running the setup utility

- (1) On your PC, run the ID/head property setup utility (BRUSBSN.EXE). The following window will appear.



- (2) On the **Model** menu, click **BH**.

MFC3100C/MFC580: Click the **Port** down arrow to select the LPT1.

FAX1800C: Click the **Port** down arrow to select the USB port to which the FAX1800C is connected.

- (3) In the **Head Info.** box, type upper 12 digits (e.g., 66667F657031) out of the 13-digit property code (enclosed with asterisks, e.g., *66667F657031H*) which is printed on the bar code label attached to the print head unit. Then press the **Enter** key.

The setup utility will transmit the entered data from your PC to the facsimile machine and then it will terminate.

The facsimile machine will automatically return to the standby mode.

- (4) To check whether the entered head property is correct, make the machine enter the maintenance mode (refer to CHAPTER 5, Section 5.1) and then press the **7** key twice.

The facsimile machine will print out the Equipment's Log. On the line about 1/3 of full length of the log sheet below from the top, the 12-digit code is printed.

NOTE: The MFC3100C may fail to print it out correctly if the four starting numerals of the entered property code are other than 6666, 7777, and 8888. To print it correctly, update the current program stored in the EEPROM.

- (5) Check that the character string entered in step (3) is printed in "XXXXXXXXXXXXX."

If it is OK, press the **9** key twice to exit from the maintenance mode.

If something other than that is printed in XXXXXXXXXXXXX, check the connection between the PC and facsimile machine and go back to step (1).

CHAPTER 3

THEORY OF OPERATION

CHAPTER 3 THEORY OF OPERATION

CONTENTS

3.1	OVERVIEW	3-1
3.2	MECHANISMS	3-2
3.2.1	Scanner Mechanism	3-3
3.2.1.1	Document feeding and ejecting mechanism	3-3
3.2.1.2	Scanner	3-3
3.2.2	Ink Jet Printing Mechanism	3-4
3.2.2.1	Paper pulling-in, registration, feeding, and ejecting mechanisms	3-4
3.2.2.2	Ink jet printing and capping mechanisms	3-6
3.2.2.3	Purging mechanism	3-9
3.2.2.4	Carriage drive mechanism	3-12
3.2.3	Sensors and Actuators	3-13
3.3	CONTROL ELECTRONICS	3-16
3.3.1	Configuration	3-16

3.1 OVERVIEW

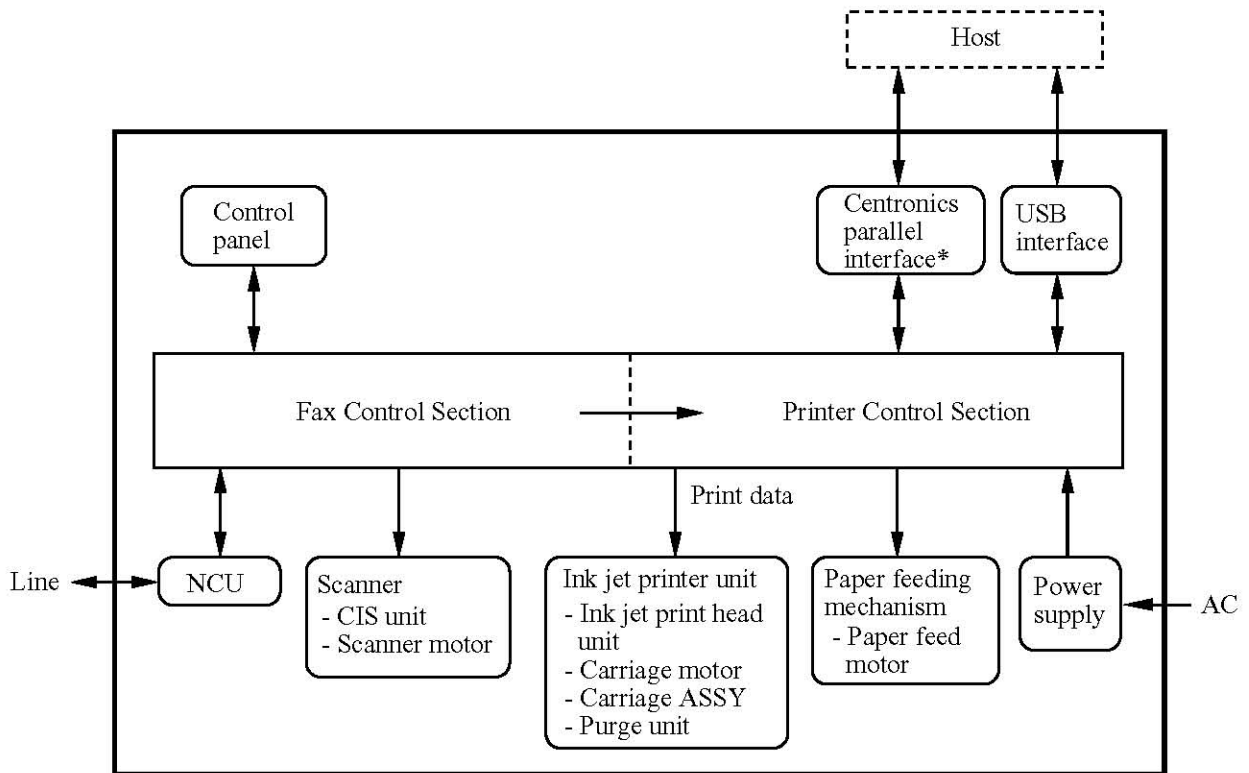

*Not provided in the FAX1800C.

3.2 MECHANISMS

The facsimile machine is classified into the following mechanisms:

- SCANNER MECHANISM
 - Document feeding and ejecting mechanism
 - Document scanning mechanism
- INK JET PRINTING MECHANISM
 - Paper pulling-in, registration, feeding, and ejecting mechanisms
 - Ink jet printing and head capping mechanisms
 - Purging mechanism
 - Carriage drive mechanism
- SENSORS AND ACTUATORS

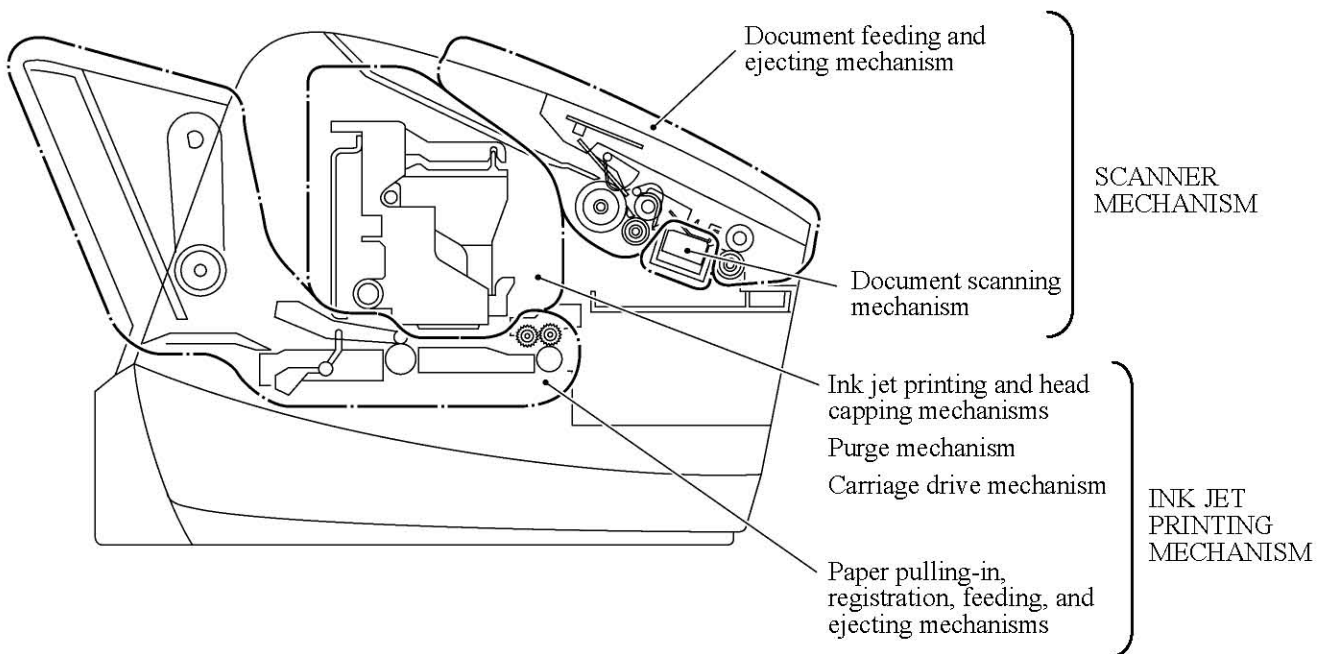

3.2.1 Scanner Mechanism

3.2.1.1 Document feeding and ejecting mechanism

This mechanism consists of the document stacker, automatic document feeder (ADF), document feed roller ASSY, document ejection roller ASSY, and document sensors. (For details about the sensors, refer to Subsection 3.2.3.)

If you set documents on the document stacker with their faces down and start the scanning operation, then the scanner motor rotates so that the ADF (which consists of the separation roller and ADF parts) feeds those documents into the machine, starting from the bottom sheet (first page) to the top (last page), page by page. Each document advances with the document feed roller ASSY to the scanner, and then it is fed out of the machine with the document ejection roller ASSY.

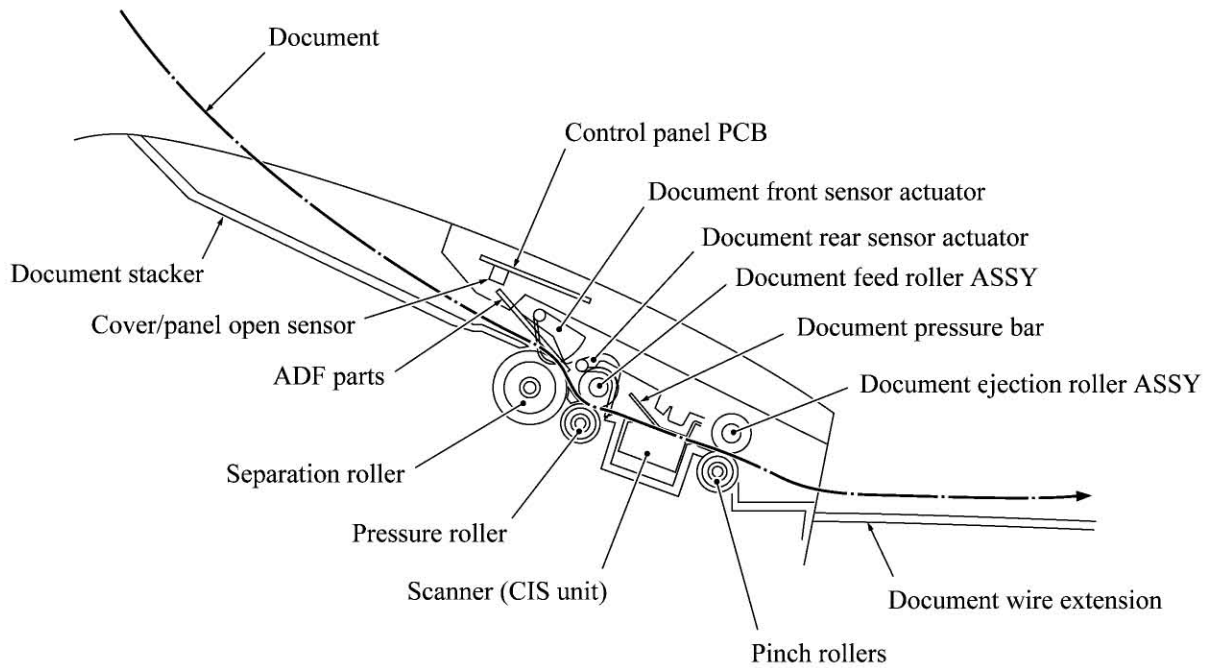

3.2.1.2 Scanner

The scanner uses a contact image sensor (CIS) unit which consists of an LED array illuminating documents, a self-focus lens array collecting the reflected light, a CIS PCB carrying out photoelectric conversion to output picture element data, and a cover glass on which a document advances. When the document passes between the document pressure bar and the cover glass, it is scanned.

3.2.2 Ink Jet Printing Mechanism

3.2.2.1 Paper pulling-in, registration, feeding, and ejecting mechanisms

The paper pulling-in, registration, feeding, and ejecting mechanisms are driven by a single paper feed motor located at the left side of the main chassis via the gear train. (See the illustration given on the next page.)

First, the paper feed motor rotates clockwise (when viewed from the output gear). The rotation is transmitted to the PF roller gear that rotates paper feed roller. At the right end of the paper feed roller is the PF roller gear R which is always engaged with the ASF/purge idle gear. Engaged with the ASF/purge idle gear, the ASF-purge switching gear 23 transmits the rotation via gear 25 and the ASF gear train to the ASF roller unit. This way, the ASF roller will pull in paper.

When the ASF roller is pulling in paper, the paper feed roller rotates in the backward direction to register the leading edge of the pulled-in paper.

Next, the paper feed motor rotates counterclockwise to rotate the paper feed roller in the forward direction. The paper will advance through the paper path. During the paper feeding operation, no rotation is transmitted to the ASF roller because of the planetary gear system built in the ASF roller unit.

The above paper pulling-in and feeding operations take place when the carriage is in printing operation. If the carriage reaches the purge position, the ASF-purge switching gear 23 will be disengaged from the gear 25 and engaged with purge bevel gear A. For the purging mechanism, refer to Subsection 3.2.2.3.

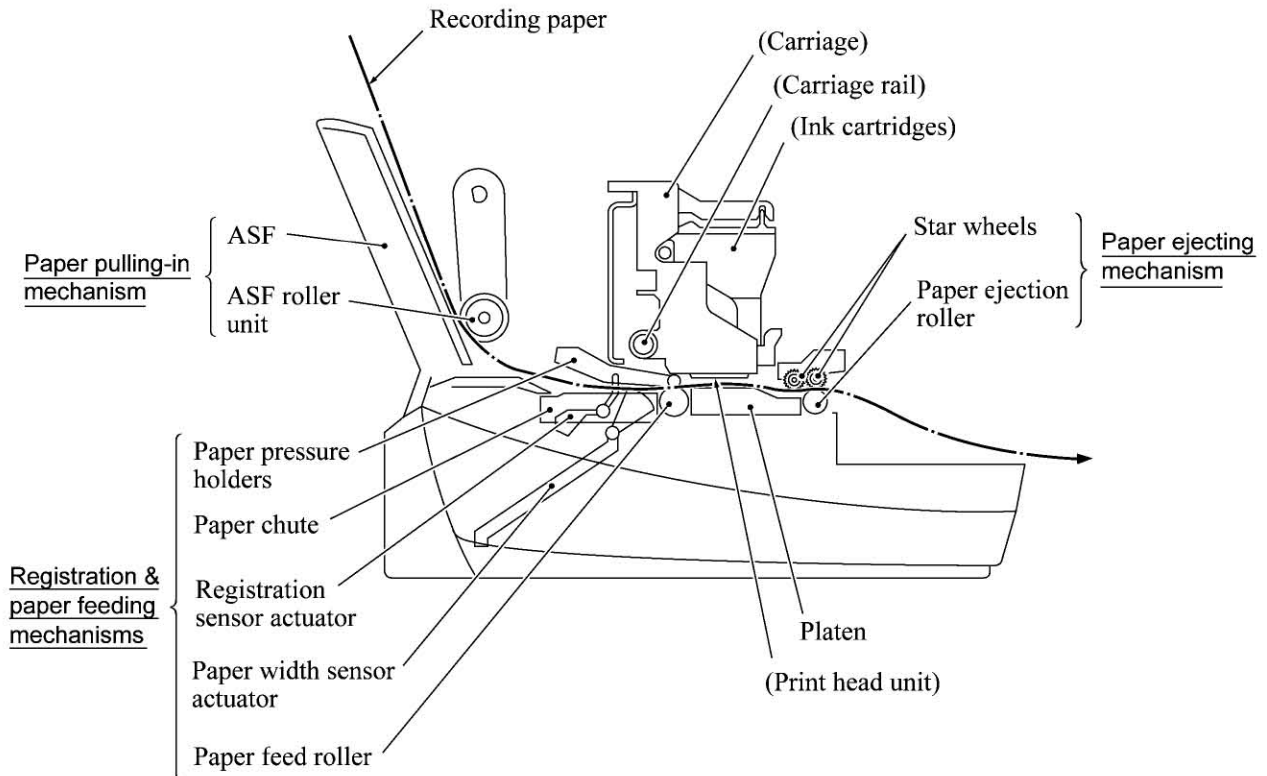

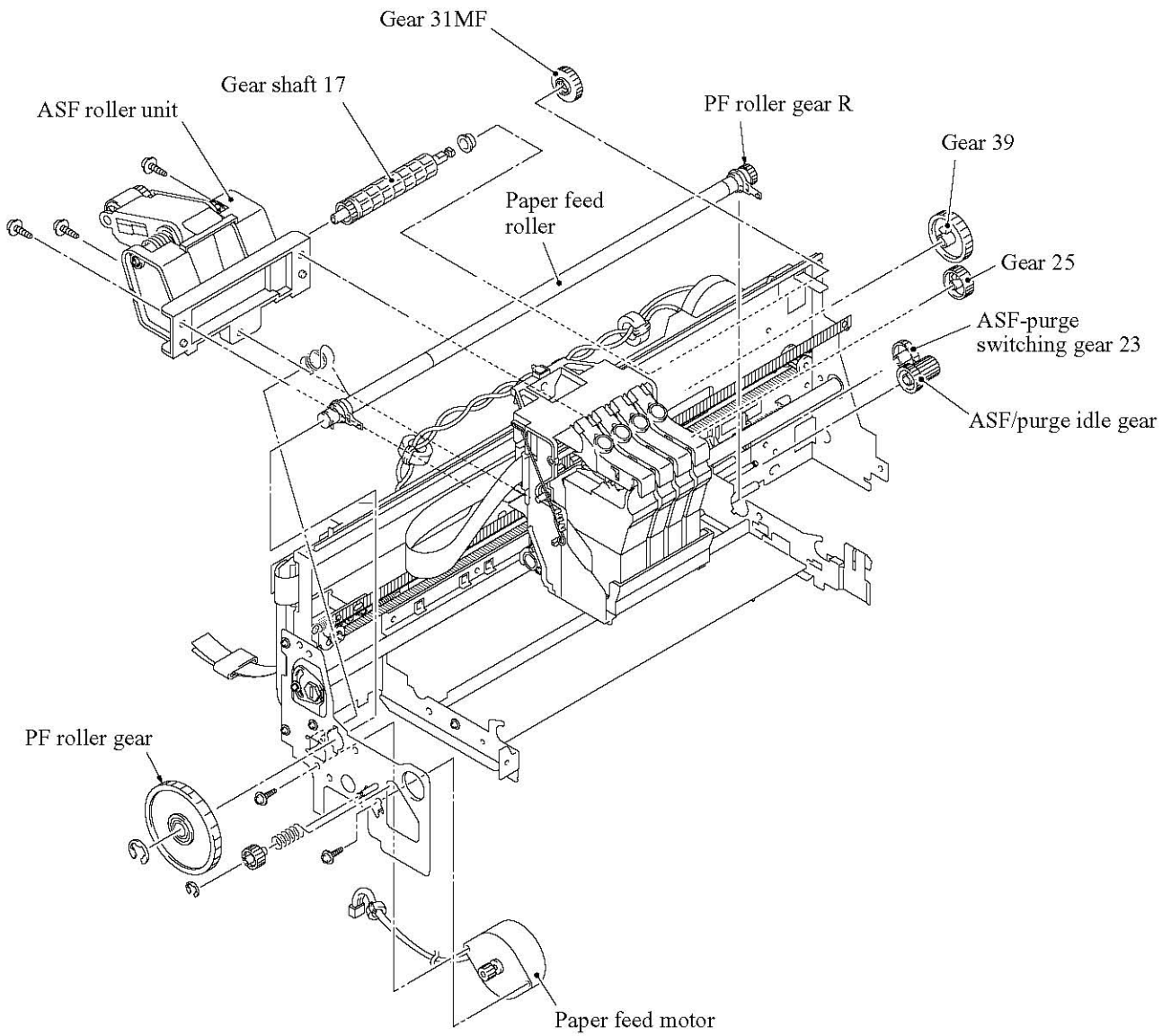

3.2.2.2 Ink jet printing and capping mechanisms

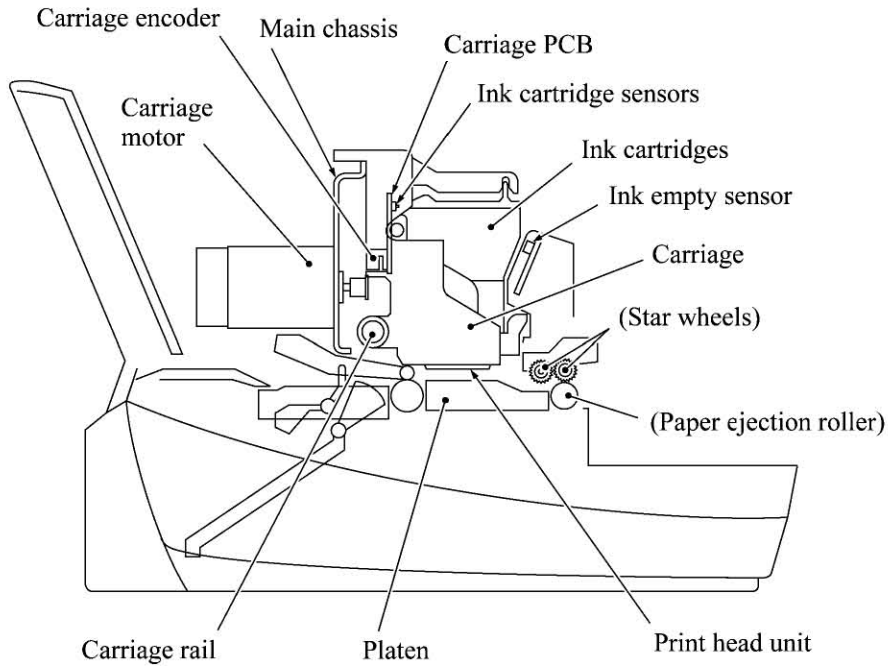

(1) Print head unit

This machine uses drop-on-demand ink jet printing. Each of the right and left print heads has an ink-jet unit that has a pair of nozzle columns for two color inks. A nozzle column consists of 75 nozzles, 75 channels covered with piezoelectric ceramic (PZT), a manifold, and filter. As illustrated below, the pair of nozzle columns is staggered.

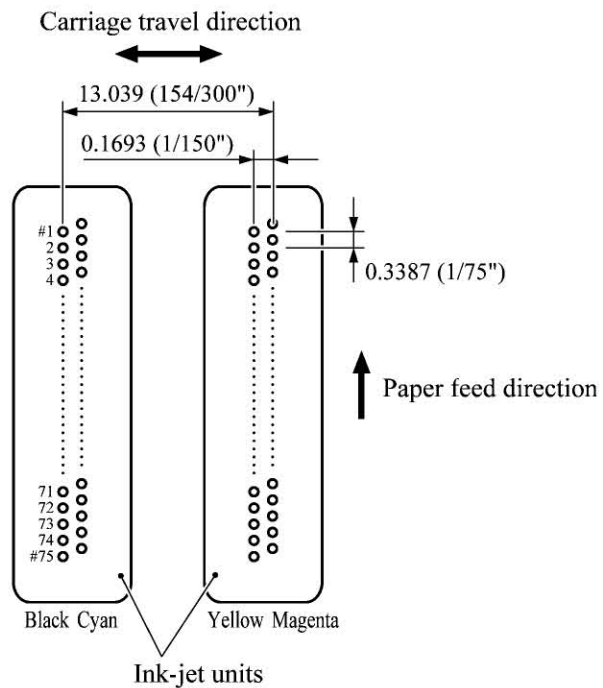

Nozzle Layout (viewed from the bottom)

If the controller issues a print command, a biased voltage will be applied to all electrodes formed on the surface of the piezoelectric ceramic so that each actuator will be distorted as shown with broken lines.

If the electrodes on a target channel are deenergized according to drive signals, then the associated piezoelectric ceramic actuator returns to the previous form so that the ink in the manifold will be vacuumed out to the channel.

If the voltage is applied again, the piezoelectric ceramic actuator will be distorted again to apply pressure to the ink in the channel, causing the ink to jet out through the nozzle. The jetted-out ink drop will be splashed and produce a dot on paper held by the platen.

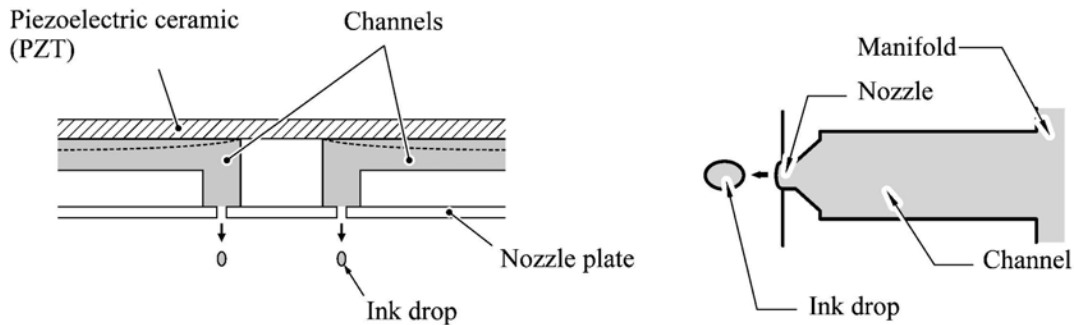

As the carriage holding the print head unit travels at the printing speed, the controller sends print command pulses to the piezoelectric actuator driver circuit embedded in the print head unit.

(2) Ink cartridges

The machine uses four ink cartridges (black, cyan, yellow, and magenta) of disposable type to supply ink to the print head unit. As shown below, an ink cartridge contains an ink-impregnated urethane foam. If ink-jet print operation or purging operation takes place, ink comes out of the urethane foam and is supplied to the print head unit through the ink room, filters, and manifold.

For the ink cartridge sensors on the carriage PCB, refer to Subsection 3.2.3.

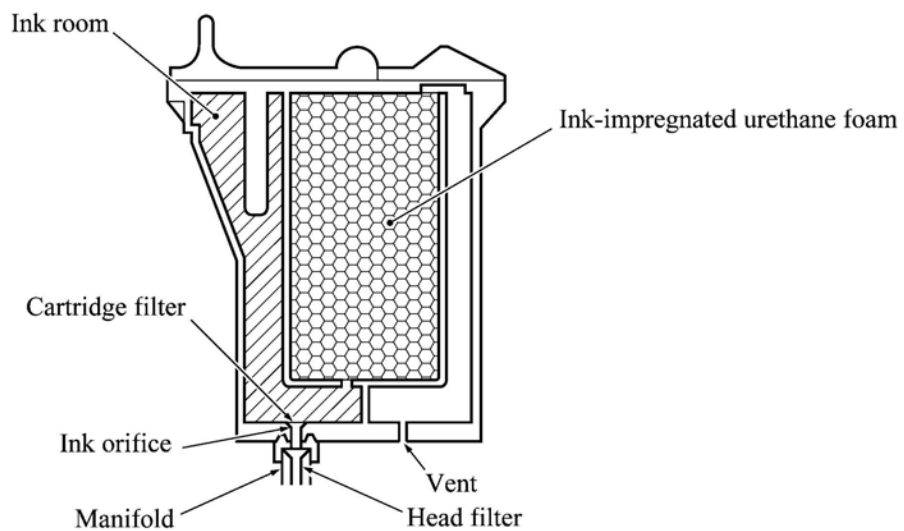

(3) Head caps

Shown below is a head cap mechanism that prevents the nozzles of the print heads from drying up when they are not in use.

Upon completion of printing, the carriage travels to the right and moves the head cap holder provided on the purge unit to the right together. In the head cap holder is a head cap unit which is supported with a lift lever. The rightward movement of the head cap holder turns the lift lever and pushes up the head cap unit to the position where the head caps come into tight contact with the print heads. This way, the nozzles will be capped.

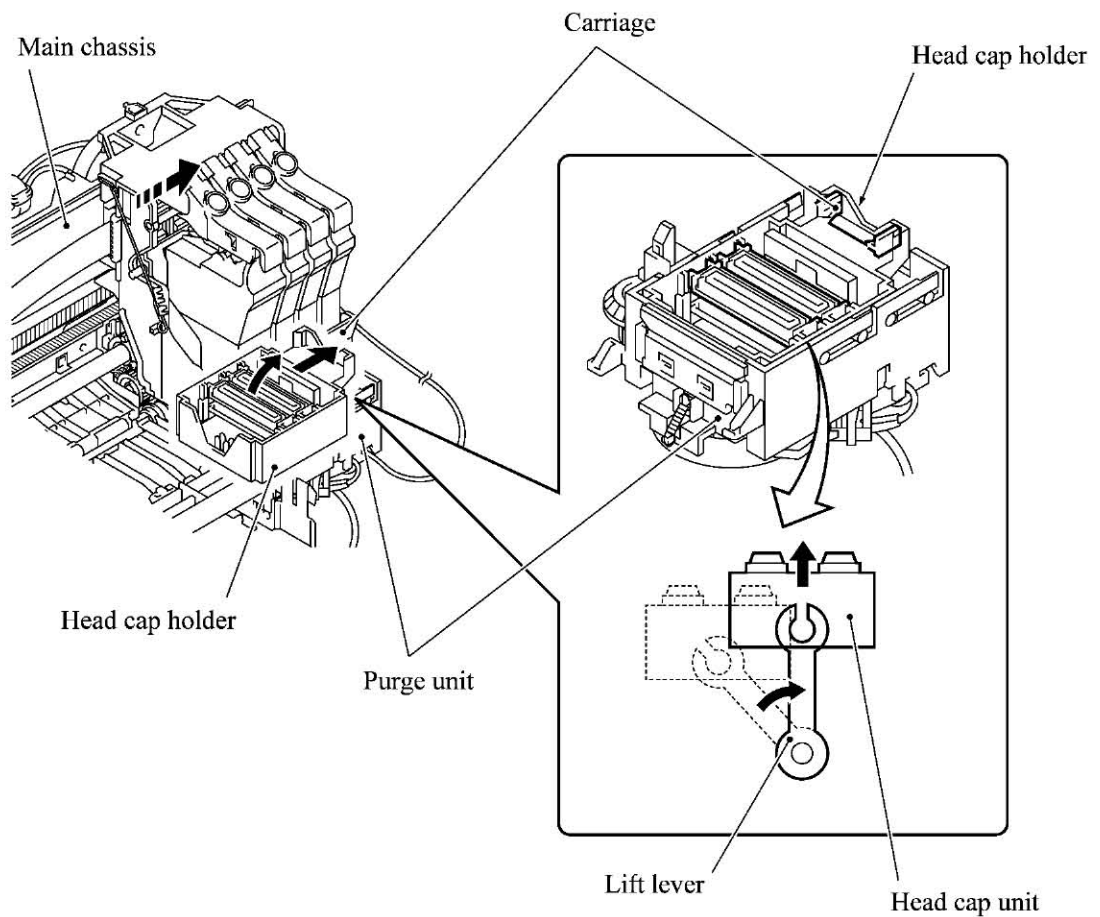

3.2.2.3 Purging mechanism

The purge mechanism is driven by the paper feed motor located at the left side of the main chassis.

As described in Subsection 3.2.2.1, the motor rotation is transmitted to the ASF/purge idle gear at the right side of the main chassis. Engaged with the ASF/purge idle gear, the ASF-purge switching gear 23 works as a clutch gear.

When the carriage travels from the left to right to reach the purge position, the tab provided on the back of the carriage pushes the purge lever on the main chassis to the right (see the illustration below). Accordingly, the ASF-purge switching gear 23 (which was shifted to the left by the purge lever) will move to the right by the switching gear spring so as to become disengaged from the gear 25 and engaged with the purge bevel gear A. (See the illustration given on the next page.) This engagement will transmit the motor rotation to the purge bevel gear B on the purge unit. This way, when the carriage is in the purge position, the motor rotation is transmitted to the purge unit.

On the contrary, if the carriage travels from the purge position to the left, the tab on the back of the carriage releases the purge lever which will be pulled back to the left. The ASF-purge switching gear 23 will be disengaged from the purge bevel gear A.

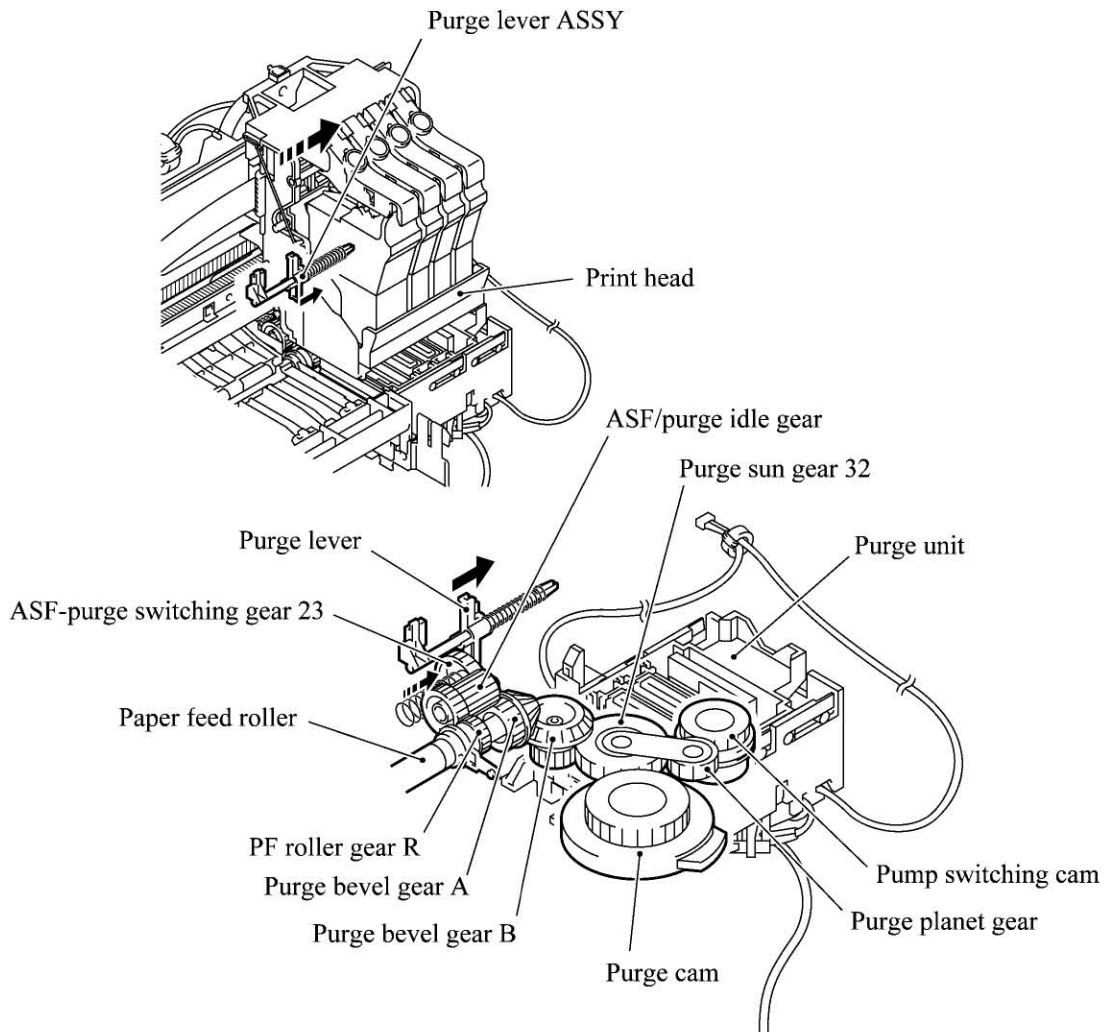

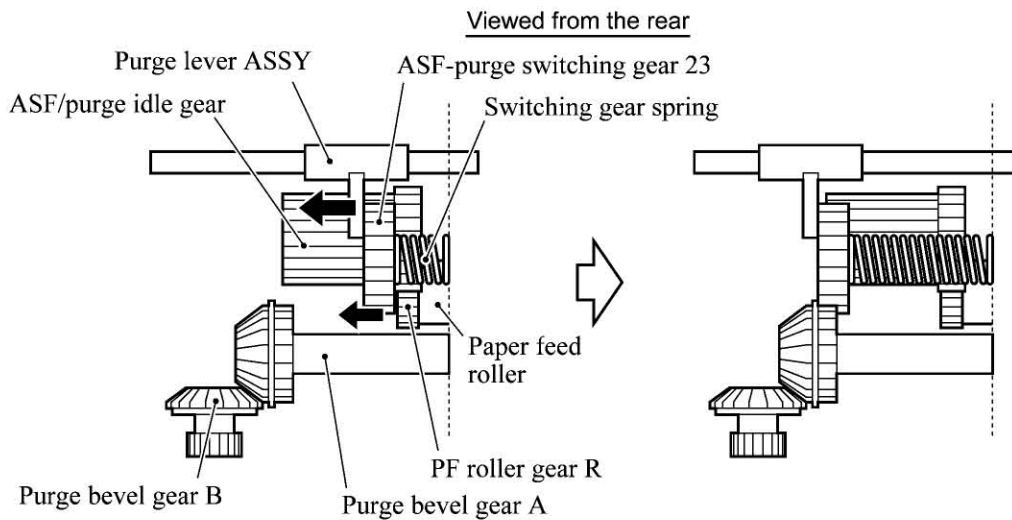

During printing: The ASF-purge switching gear 23 is not engaged with purge bevel gear A (but engaged with gear 25 in the ASF gear train).

During purging: The ASF-purge switching gear 23 is engaged with purge bevel gear A.

When the motor rotation is transmitted to the purge unit, its counterclockwise rotation will drive the purge cam and its clockwise rotation, the pump switching unit (when viewed from the output gear of the motor).

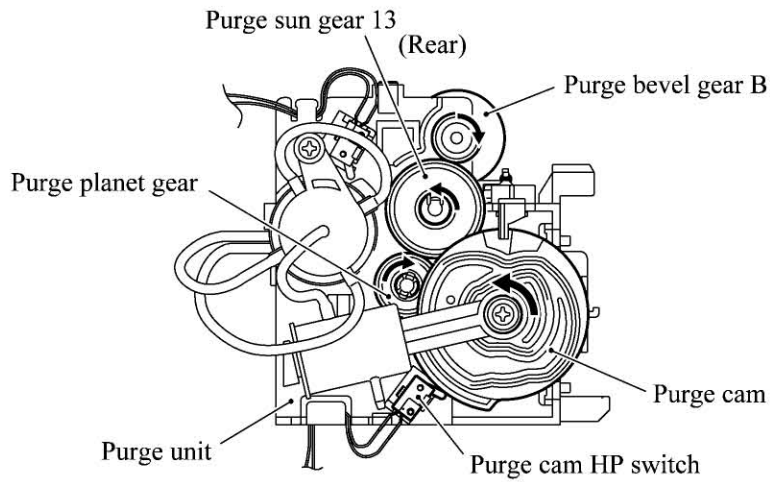

When the paper feed motor rotates counterclockwise

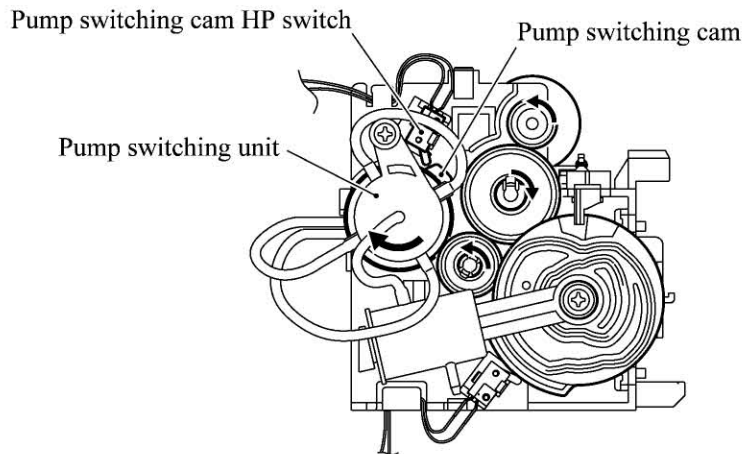

When the paper feed motor rotates clockwise

The purge cam is so designed that:

- the carriage lock pops out to lock the carriage before purging and pops in before cleaning with the head wiper (see the illustration below),
- the pump works to draw out ink from each of the four head nozzles and drain it to the ink absorber felts, and
- the head wiper comes out to clean the nozzle surface (see the illustration below).

The pump switching cam is so designed that:

- the pump switching unit switches application of the pump's negative pressure between the four head nozzles in the order of black, cyan, yellow, and magenta nozzles. When the pump switching cam is in the home position, normal atmospheric pressure will be restored.

The home position of the purge cam and pump switching cam are detected by their HP switches. For those switches, refer to Subsection 3.2.3.

(1) Carriage lock

If the purge cam is driven, the carriage lock of the purge unit pops out and locks the carriage to align ink-jet units with the mating head caps during purge operation. After purging but before cleaning with the head wiper, it pops in to release the carriage. When the power is off, the carriage lock keeps the print heads pressed against the head caps.

(2) Purging

If activated, the pump draws out ink to purge air bubbles or dust from the inside of the head nozzles and channels. As the purge cam rotates by one turn, the piston of the pump reciprocates two strokes. To complete purging of all four nozzles and channels, the purge cam rotates by two turns and the piston reciprocates four strokes.

(3) Draining

The pump drains drawn ink into the ink absorber felts.

(4) Cleaning with the head wiper

After purging operation, the head wiper comes out and the carriage moves from the right to left so as to clean ink remaining on the heads' surface.

(5) Restoring the pump's pressure to normal atmospheric pressure

When the pump switching cam is in the home position, the controller stops to produce negative pressure and restore the pump's pressure to normal atmospheric pressure.

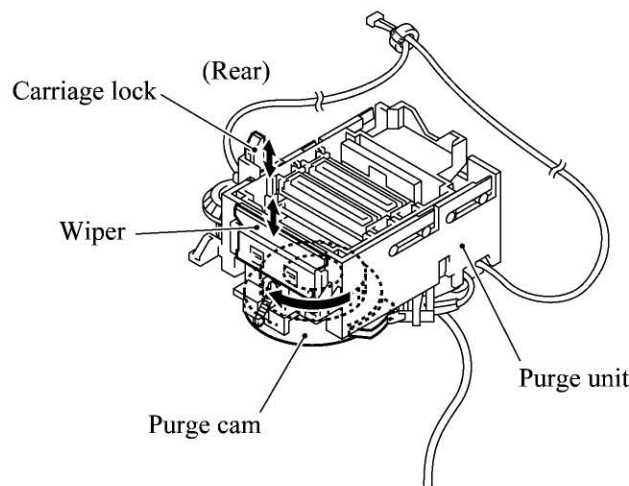

3.2.2.4 Carriage drive mechanism

The carriage motor controls horizontal motion. The motor rotation is transmitted via the motor pulley to the timing belt.

The carriage, which is supported and guided by the carriage rail, is secured to the timing belt. Clockwise and counterclockwise rotations of the carriage motor move the carriage to the right and left, respectively.

On the back of the carriage is the carriage encoder which tells the control circuitry the current carriage position counted based on the carriage motor position by using the encoder strip attached to the main chassis.

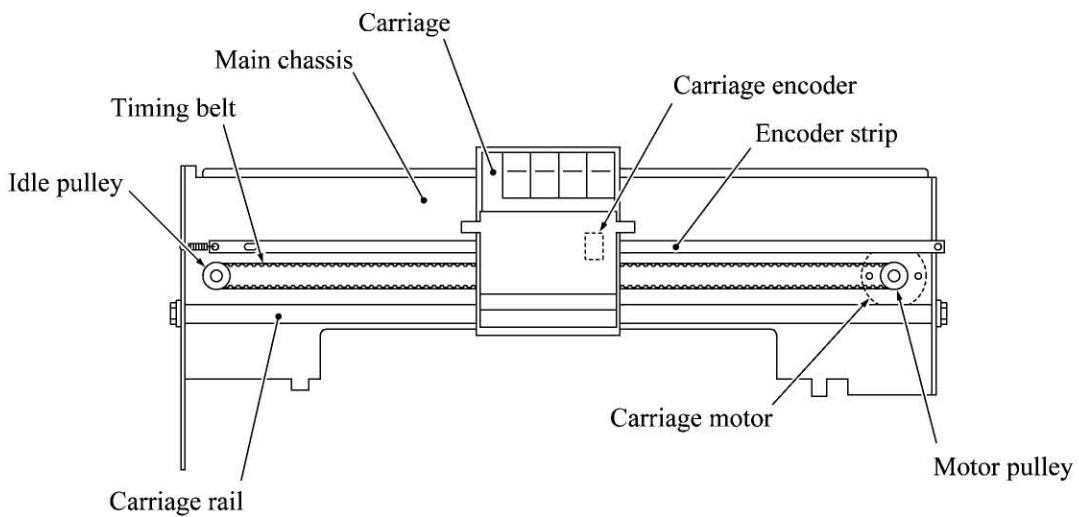

3.2.3 Sensors and Actuators

This machine has the following sensors and thermister.

Sensor name	Type	Located on
Document front sensor	Photosensor	
Document rear sensor	Photosensor	Control panel PCB
Cover/panel open sensor	Mechanical switch	
Registration sensor	Photosensor	Paper chute
Paper width sensor	Photosensor	Main PCB
Ink empty sensor	Photosensor	Sensor support
Ink cartridge sensors	Mechanical switches	
Carriage encoder	Photosensor	Carriage PCB
Head thermister	Thermister	
Purge cam HP switch	Mechanical switch	Purge unit
Pump switching cam HP switch	Mechanical switch	
Hook switch*	Mechanical switch	Hook switch PCB*

*Provided in the FAX1800C.

- Document front sensor which detects the presence of documents.
- Document rear sensor which detects the leading and trailing edges of pages to tell the control circuitry when the leading edge of a new page has reached the starting position and when the scan for that page is over.
- Cover/panel open sensor which detects whether the top cover and control panel are closed.
- Registration sensor which detects the leading and trailing edges of paper, which allows the controller to determine the registration timing and check paper jam.
- Paper width sensor which detects whether the paper width is "A4-size or wider" or "narrower than A4-size."
- Ink empty sensor which detects at the start of printing whether any of the four ink cartridges is near empty. According to this sensor signal, the controller may display "NEAR EMPTY XXX" message.
- Ink cartridge sensors, each of which detects whether an ink cartridge is loaded.
- Carriage encoder which detects the current carriage position and carriage travel speed. If the carriage travels speed varies abnormally, the controller regards it as a paper jam.
- Head thermister which allows the controller to control the temperature of the print heads. According to the change of the thermister's internal resistance monitored, the control circuitry regulates the drive voltage applied to the piezoelectric ceramic actuators on each print head since the viscosity of the ink varies depending upon the temperature.
- Purge cam HP switch which detects whether the purge cam is in the home position.
- Pump switching cam HP switch which detects whether the pump switching cam is in the home position.
- Hook switch which detects whether the handset is on the hook.

These photosensors (except the ink empty sensor that is a reflection type) are a photointerrupter consisting of a light-emitting diode and a light-sensitive transistor. Each of them has an actuator separately arranged as shown on the next page.

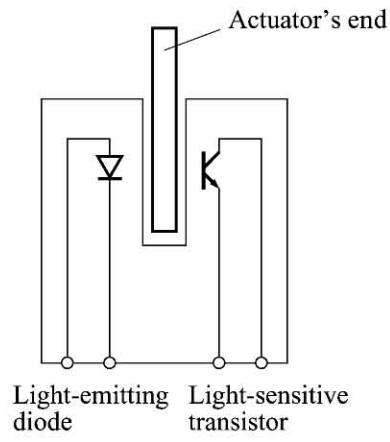

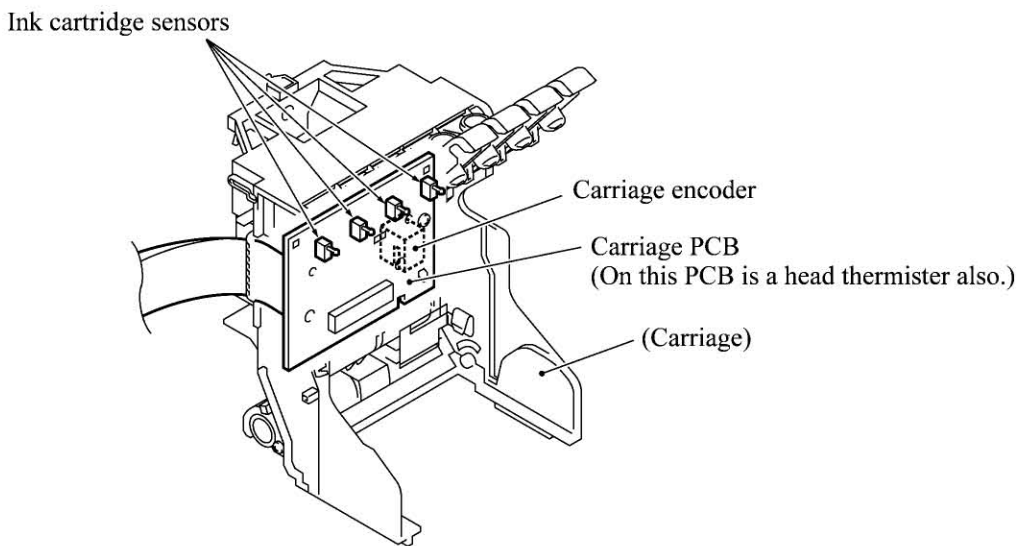
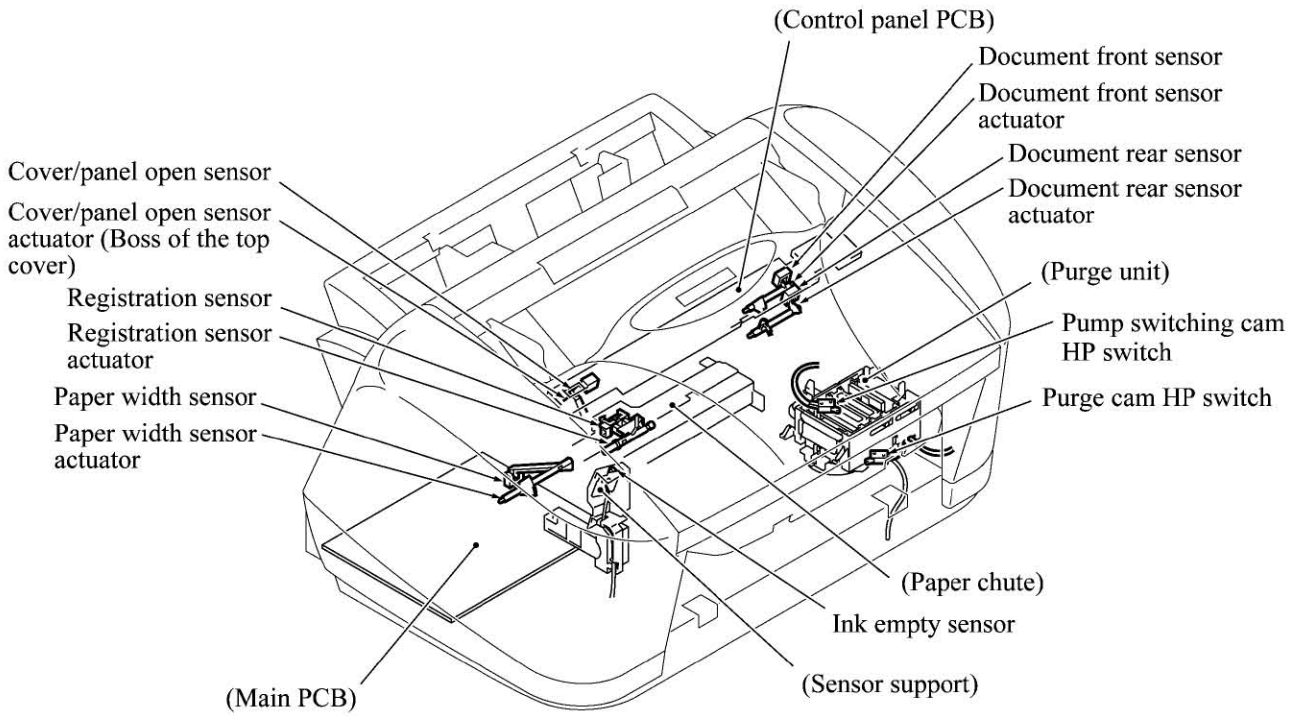

Location of Sensors and Actuators

NOTE: The hook switch (not shown above) is provided in the FAX1800C.

3.3 CONTROL ELECTRONICS

3.3.1 Configuration

The hardware configuration of the facsimile machine is shown below.

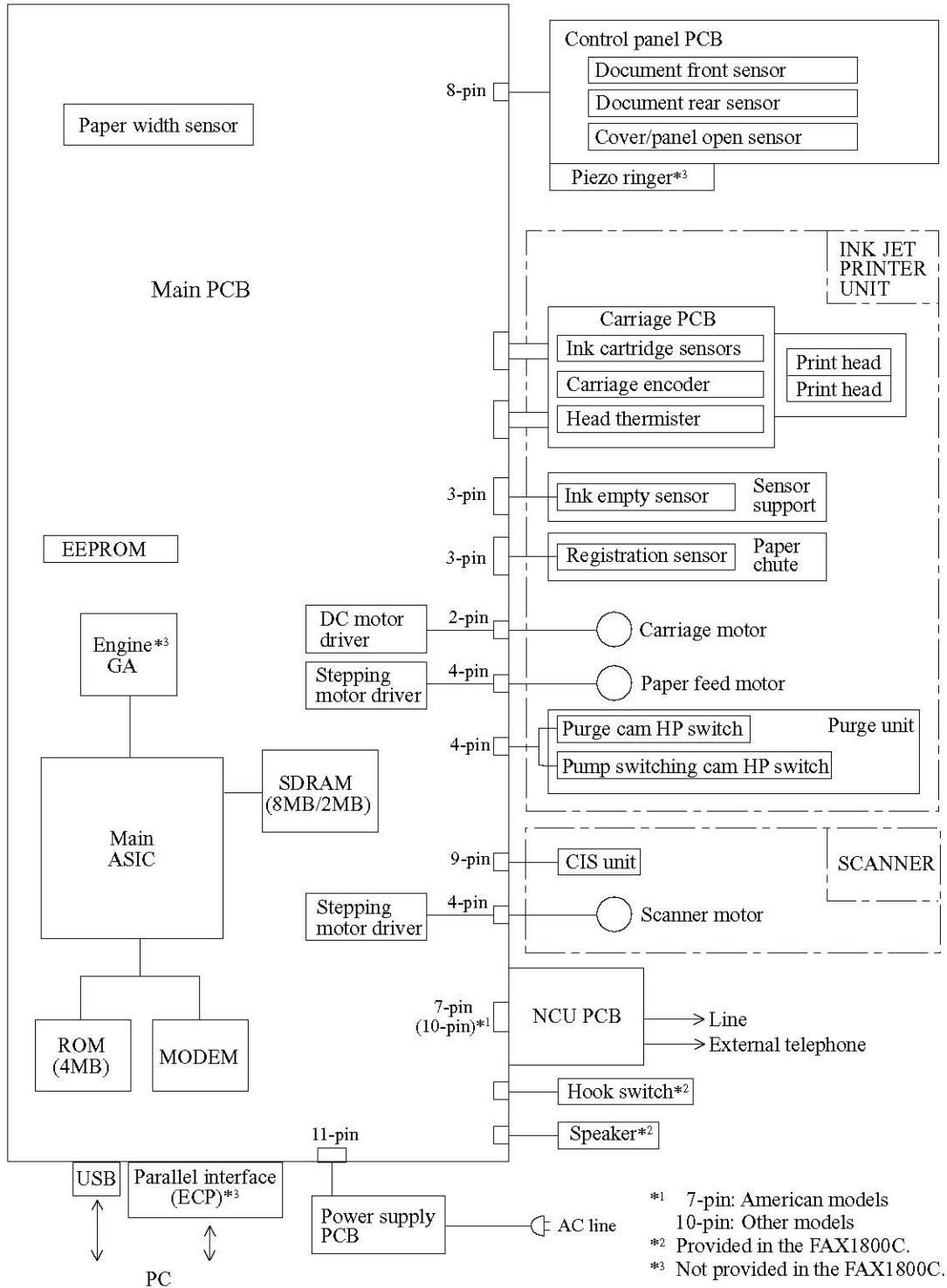

Configuration of Facsimile Machine

CHAPTER 4 DISASSEMBLY/REASSEMBLY, LUBRICATION, ADJUSTMENT

CONTENTS

4.1	DISASSEMBLY/REASSEMBLY	4-1
■	Safety Precautions	4-1
	Tightening Torque List	4-2
■	Preparation	4-3
■	How to Access the Object Component	4-3
■	Disassembly Order Flow	4-4
4.1.1	Print Head Unit	4-5
4.1.2	Jam Clear Cover and Auto Sheet Feeder (ASF)	4-9
4.1.3	Bottom Plate, Ink Absorber Box, Main PCB, NCU PCB, and Power Supply PCB	4-11
4.1.4	Enclosure Cover and Paper Width Sensor Actuator	4-16
4.1.5	Top Cover	4-17
4.1.6	Control Panel ASSY	4-18
4.1.7	Panel Rear Cover and Control Panel	4-19
4.1.8	CIS Unit	4-22
4.1.9	Upper Cover	4-23
4.1.10	Document Feed Roller ASSY, Document Ejection Roller ASSY, Pressure Roller, and Pinch Rollers	4-25
4.1.11	Panel Lock Springs, Scanner Chassis, Separation Roller, Scanner Drive Unit, and Scanner Motor	4-26
4.1.12	Purge Unit	4-29
4.1.13	Main Chassis	4-31
4.1.14	ASF Roller Unit and its Related Gears	4-32
4.1.15	Roller Pressure Holders	4-34
4.1.16	Paper Chute and Registration Sensor	4-35
4.1.17	Paper Ejection Roller Gear, Ink Empty Sensor PCB, Platen, Star Wheel Support, and Paper Ejection Roller	4-37
4.1.18	Paper Feed Motor and Paper Feed Roller	4-40

4.1.19	Encoder Strip and Carriage Motor.....	4-41
4.1.20	Carriage Rail, Carriage ASSY, and Purge-Related Parts	4-43
4.1.21	Flushing Box.....	4-48
4.1.22	Harness Routing.....	4-49
4.2	LUBRICATION	4-51
4.3	ADJUSTMENT	4-56

4.1 DISASSEMBLY/REASSEMBLY

■ Safety Precautions

To prevent the creation of secondary problems by mishandling, observe the following precautions during maintenance work.

- (1) Unplug the power cord from the power outlet before replacing parts or units. When having access to the power supply, be sure to unplug the power cord from the power outlet.
- (2) Be careful not to lose screws, washers, or other parts removed for parts replacement.
- (3) When using soldering irons and other heat-generating tools, take care not to damage the resin parts such as wires, PCBs, and covers.
- (4) Before handling the PCBs, touch a metal portion of the machine to discharge static electricity; otherwise, the electronic parts may be damaged due to the electricity charged in your body.
- (5) When transporting PCBs, be sure to wrap them in conductive sheets such as aluminum foil.
- (6) Be sure to reinsert self-tapping screws correctly, if removed.
- (7) Tighten screws to the torque values listed on the next page.
- (8) When connecting or disconnecting cable connectors, hold the connector bodies not the cables. If the connector has a lock, always slide the connector lock to unlock it.
- (9) Before reassembly, apply the specified lubricant to the specified points. (Refer to Subsection 4.2 in this chapter.)
- (10) After repairs, check not only the repaired portion but also that the connectors and other related portions function properly before operation checks.
- (11) Once the print head unit prints, it will start head locking operation after five seconds from the end of printing. The head locking operation will take 5 to 10 seconds. NEVER unplug the power cord before the machine completes the head locking operation; doing so will make the print head unit unusable and require replacement with a new print head unit.

When you receive the machine from the user or when you pack it for sending it back to the user, check the head locking state.

Tightening Torque List

Location	Screw type	Q'ty	Tightening torque N•m (kgf•cm)	
ASF	Taptite, bind B M4x12	4	0.88 ±0.10	(9 ±1)
Bottom plate	Taptite, cup B M3x12	9	0.78 ±0.10	(8 ±1)
Grounding terminal	Screw, pan (washer) M4x8	1	0.59 ±0.10	(6 ±1)
Bottom shield plate	Taptite, cup B M3x12	2	0.78 ±0.10	(8 ±1)
	Taptite, cup S M3x5	2	0.49 ±0.10	(5 ±1)
Parallel & USB I/F connectors	Screw, pan M3x6	3	0.39 ±0.10	(4 ±1)
FG plate R (Lower cover) (Main chassis)	Taptite, cup B M3x12	1	0.78 ±0.10	(8 ±1)
	Taptite, cup S M3x5	1	0.78 ±0.10	(8 ±1)
ADF parts	Taptite, cup B M3x6	1	0.49 ±0.10	(5 ±1)
Panel rear cover	Taptite, cup B M3x8	2	0.49 ±0.10	(5 ±1)
CIS side spring	Taptite, cup B M3x10	1	0.78 ±0.10	(8 ±1)
Upper cover	Taptite, bind B M4x12	2	0.88 ±0.10	(9 ±1)
Panel lock spring R	Taptite, cup S M3x5	1	0.98 ±0.10	(10 ±1)
Panel lock spring L	Taptite, cup B M3x10	1	0.78 ±0.10	(8 ±1)
Scanner chassis	Taptite, cup B M3x10	4	0.78 ±0.10	(8 ±1)
Scanner motor	Screw, pan (s/p washer) M3x6DA	1	0.49 ±0.10	(5 ±1)
Purge unit	Taptite, cup B M3x8	2	0.59 ±0.10	(6 ±1)
FG plate L	Taptite, cup S M3x5	1	0.78 ±0.10	(8 ±1)
ASF roller unit	Taptite, cup S M3x6	3	0.98 ±0.10	(10 ±1)
ASF gear holders	Taptite, cup B M3x10	1	0.49 ±0.10	(5 ±1)
Paper chute	Taptite, cup S M3x6	1	0.98 ±0.10	(10 ±1)
Sensor support	Taptite, cup S M3x6	1	0.98 ±0.10	(10 ±1)
Ink empty sensor PCB	Taptite, cup B M3x8	1	0.59 ±0.10	(6 ±1)
Platen	Shoulder screw	1	0.59 ±0.10	(6 ±1)
	Screw, bind B tite, M3x10	1	0.59 ±0.10	(6 ±1)
Platen plate R	Taptite, bind B M2.6x10	1	0.39 ±0.10	(4 ±1)
Platen plate L	Taptite, bind B M2.6x10	1	0.39 ±0.10	(4 ±1)
Paper feed motor	Screw, pan (s/p washer) M3x6	2	0.78 ±0.10	(8 ±1)
Idle pulley holder	Taptite, cup S M3x8	1	0.98 ±0.10	(10 ±1)
	Shoulder screw	1	0.78 ±0.10	(8 ±1)
	Screw, cup S tite, M3x6	1	0.98 ±0.10	(10 ±1)
Carriage motor	Screw, pan (s/p washer) M3x6	2	0.78 ±0.10	(8 ±1)
Eccentric bushings R, L	Screw, pan (s/p washer) M3x6DB	2	0.78 ±0.10	(8 ±1)

■ Preparation

Prior to proceeding to the disassembly procedure,

(1) Unplug

- the modular jack of the telephone line,
- the modular jack of the curled cord* (and remove the handset*),
- the PC interface cable if connected (Not shown below), and
- the modular jack of an external telephone set if connected (Not shown below).

*Provided in the FAX1800C.

(2) Remove

- the document support,
- the paper wire extension,
- the document wire extension, and
- the paper tray.

NOTE: Do not remove the ink cartridges when disassembling the machine except when removing the print head unit.

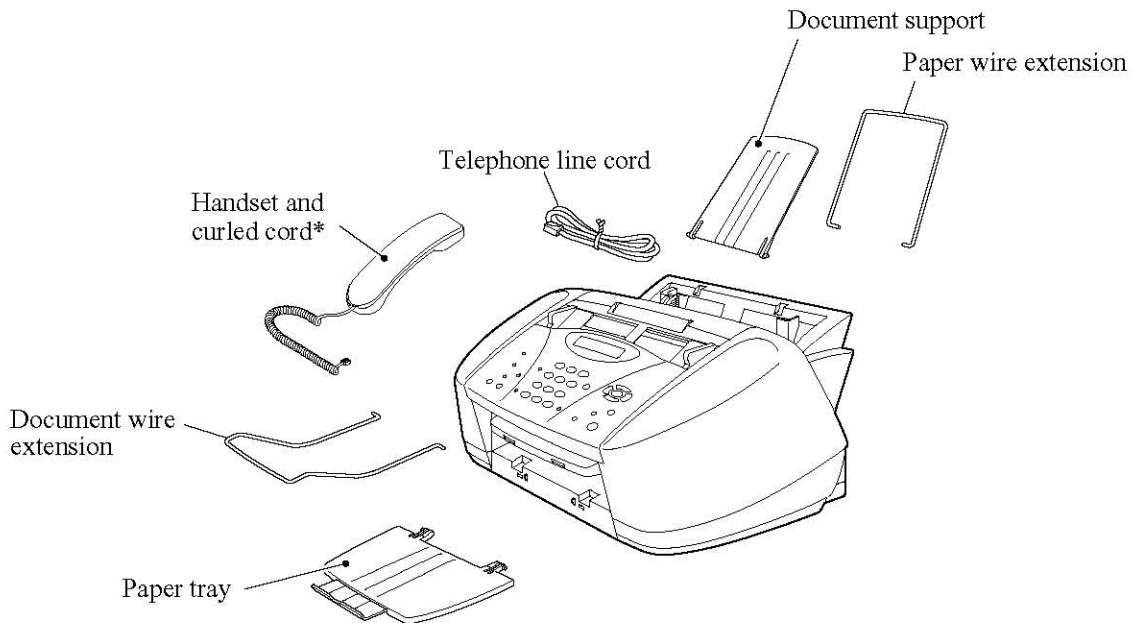

* Provided in the FAX1800C.

■ How to Access the Object Component

- On the next page is a disassembly order flow which helps you access the object components. To remove the platen, for example, first find it on the flow and learn its number (4.1.17 in this case). You need to remove parts numbered 4.1.1, 4.1.2, 4.1.9, 4.1.13, 4.1.15, and 4.1.16 so as to access the platen.
- Unless otherwise specified, the disassembled parts or components should be reassembled in the reverse order of removal.

■ Disassembly Order Flow

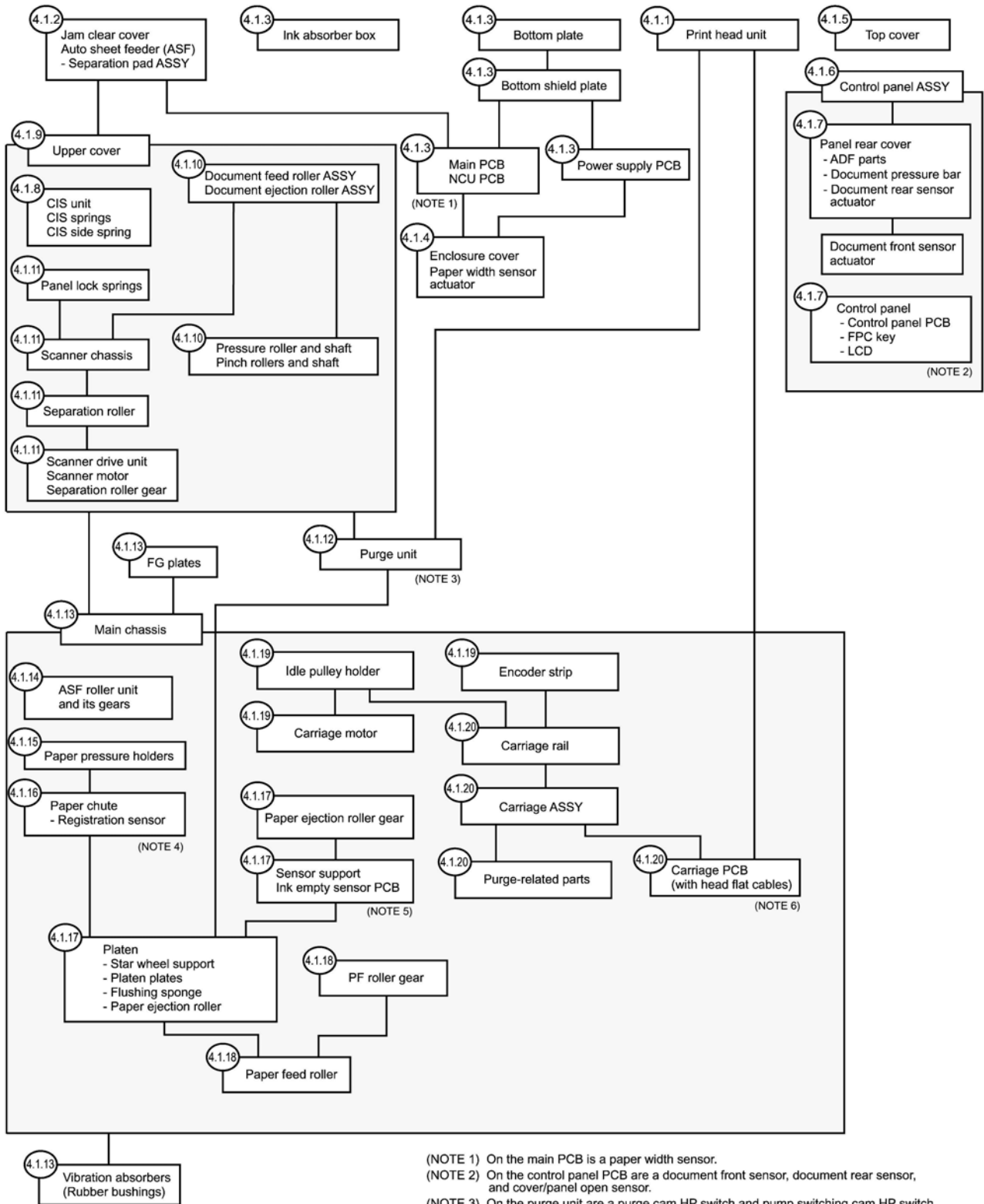

(NOTE 1) On the main PCB is a paper width sensor.

(NOTE 2) On the control panel PCB are a document front sensor, document rear sensor, and cover/panel open sensor.

(NOTE 3) On the purge unit are a purge cam HP switch and pump switching cam HP switch.

(NOTE 4) On the paper chute is a registration sensor.

(NOTE 5) On the sensor support is an ink empty sensor.

(NOTE 6) On the carriage PCB are four ink cartridge sensors, a carriage encoder, and head thermister.

4.1.1 Print Head Unit

During disassembly jobs (except when removing the purge unit, carriage rail, or carriage ASSY), the print head unit and all the four ink cartridges should be kept in place.

NOTE: To replace the print head unit with a new one, you need to move the carriage to the ink replacement position by placing the machine in the ink replacement mode. Do not move the carriage by hand when the power is off.

NOTE: If you replace the print head unit with a new one, replace also the ink absorber box and ink cartridges with new ones.

- (1) Plug the power cord into a wall socket.
- (2) Press the **Ink** key to place the machine in the ink replacement mode.
- (3) Press the **2** key to choose "2. REPLACE INK."
- (4) Press the **Menu/Set** key.

The carriage automatically moves to the ink replacement position.

- (5) Unplug the power cord from the wall socket.
- (6) Open the control panel ASSY and top cover.
- (7) Push the colored ink cartridge covers and remove all ink cartridges. (Or, remove the shipping cover.)

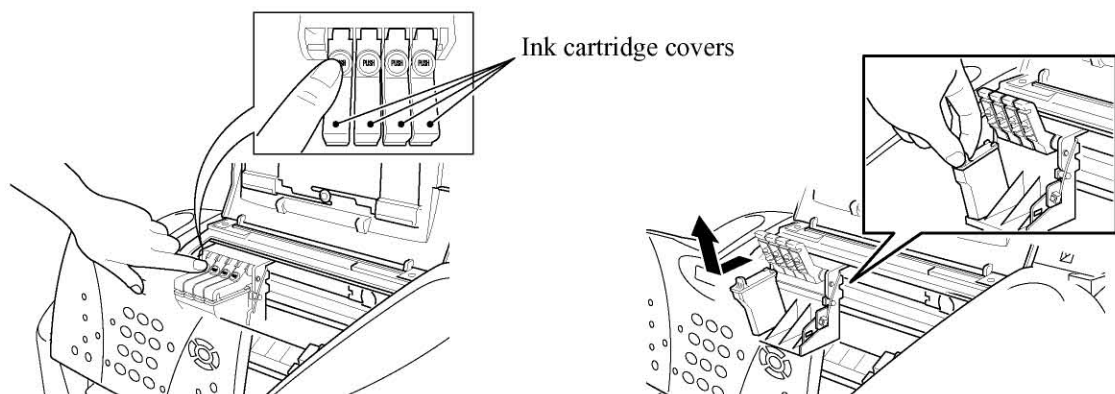

- (8) Pull the head clamp springs in the direction of arrows ① shown below to release the print head unit.
- (9) Lift the print head unit up and out of the carriage (arrow ②).

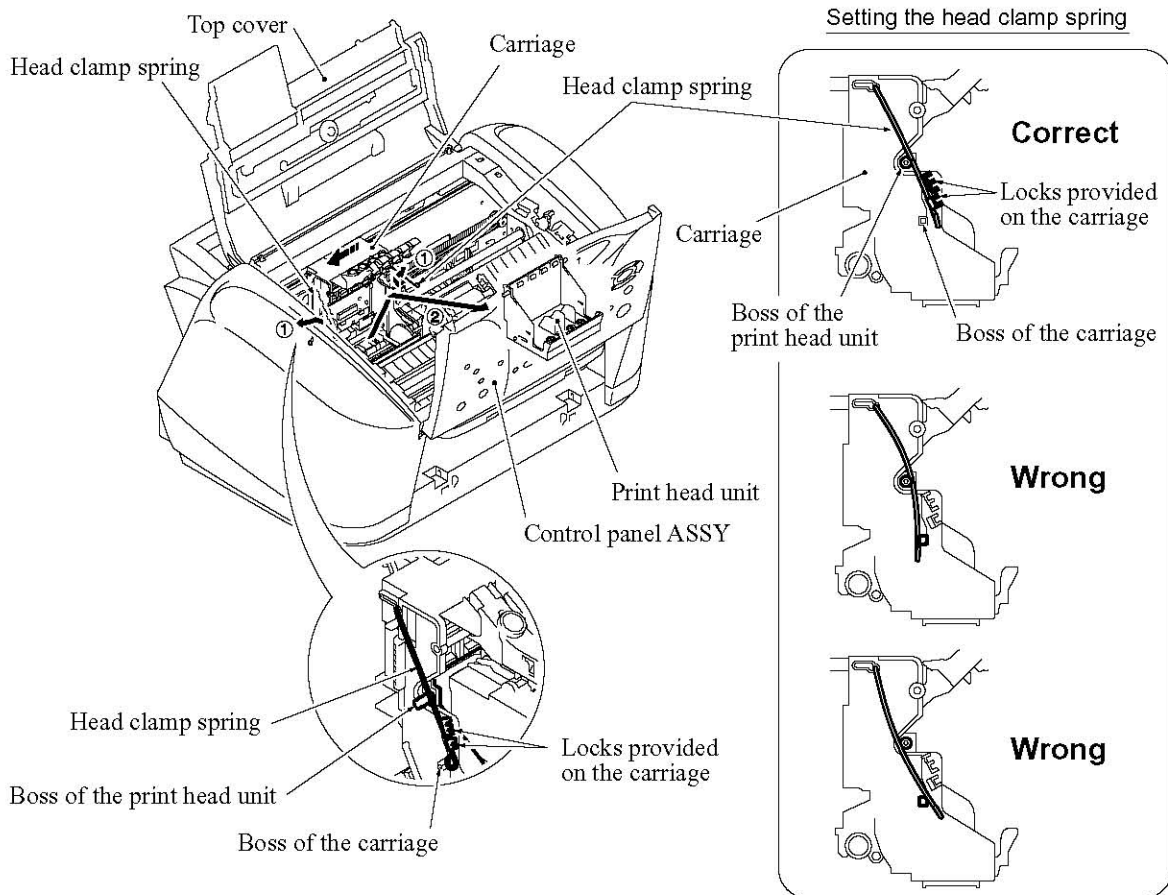

NOTE: Do not touch the printing ends (nozzles) of the print head unit or the ink orifices of the ink cartridges; doing so will not only stain your hands with ink but result in an ink jet-out failure. Once you touch them, clean them with a dedicated cleaning stick and liquid.

NOTE: Be sure to put a head nozzle seal and filter seal on the print head unit as shown below. Leaving the print head unit without those seals will dry up its printing ends and filters, resulting in a damaged head.

NOTE: Do not touch the dimple contact section of the print head unit.

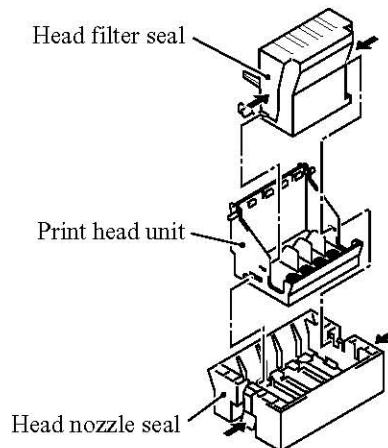

NOTE: Once the ink cartridges are removed, their colored covers rise upright. If you turn the machine upside down with those covers being upright, then they will break. To prevent it, set them to the horizontal position by turning them in the direction of arrow ① and pushing them up in the direction of arrow ②.

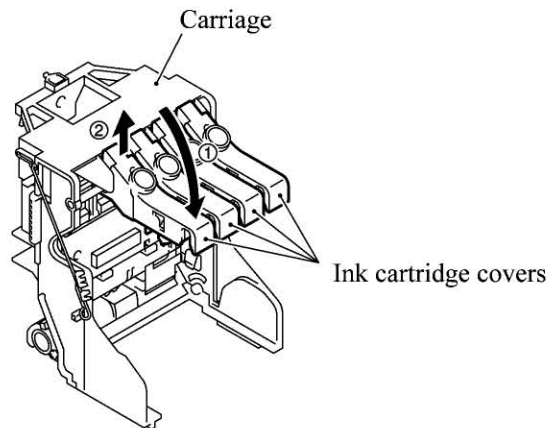

(10) Turn the head adjuster lever located on the right side of the carriage to position 1.

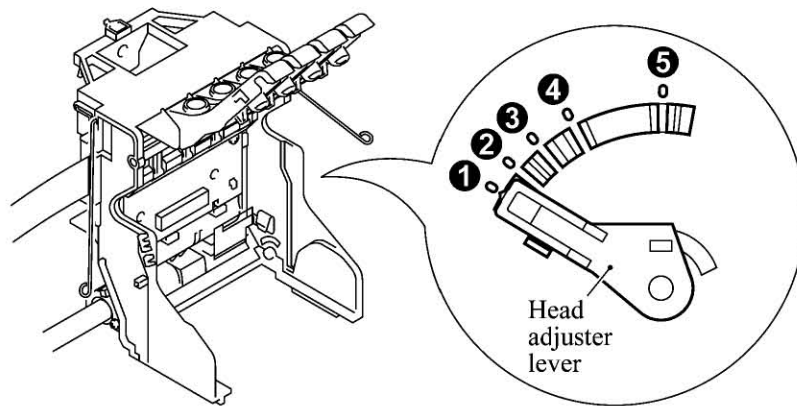

(11) To install a new (or removed) print head unit, remove the head nozzle seal.

(12) Put the print head unit into the carriage with care for the dimple contact so that the electrical contact on the head PCB comes into uniform contact with that on the carriage PCB as illustrated below.

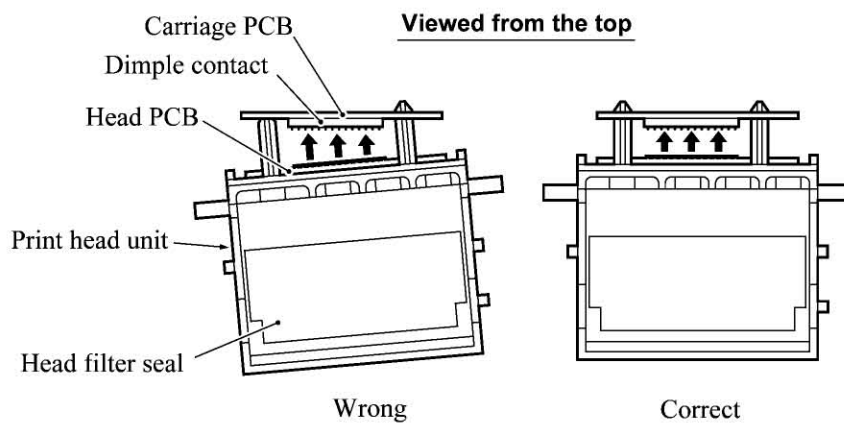

- (13) Press the front center of the carriage to the rear and move the print head unit to the right and left several times. This is to assure the dimple contact between the head PCB and carriage PCB.

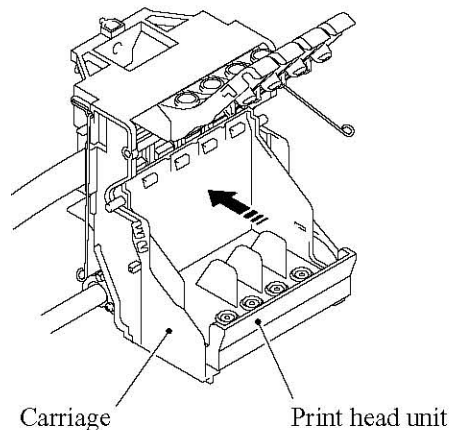

- (14) While pressing the front center of the print head unit, lock the print head unit with the head clamp springs.
- (15) Remove the head filter seal.
- (16) Set new ink cartridges into the carriage.
- (17) Press the bottom right front corner of the carriage to the rear.

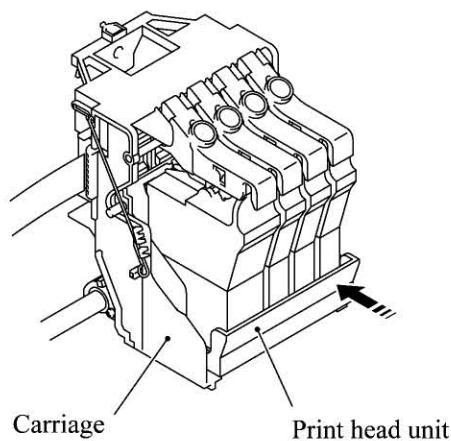

- (18) Close the top cover and control panel.
- (19) Plug the power cord into a wall socket.
- The carriage automatically moves to the right-hand home position.
- (20) Follow the instructions shown on the LCD.
- NOTE:** The machine enters a "head cleaning" cycle that takes approx. 3 minutes for each ink cartridge.
- (21) Load paper into the ASF.
- (22) Correct the positioning error of the print head unit, referring to Section 4.3 "ADJUSTMENT."
- (23) Adjust the alignment of vertical print lines, referring to CHAPTER 5, Subsection 5.3.13.

4.1.2 Jam Clear Cover and Auto Sheet Feeder (ASF)

- (1) Remove the jam clear cover.
- (2) Remove the four screws from the ASF to release it.

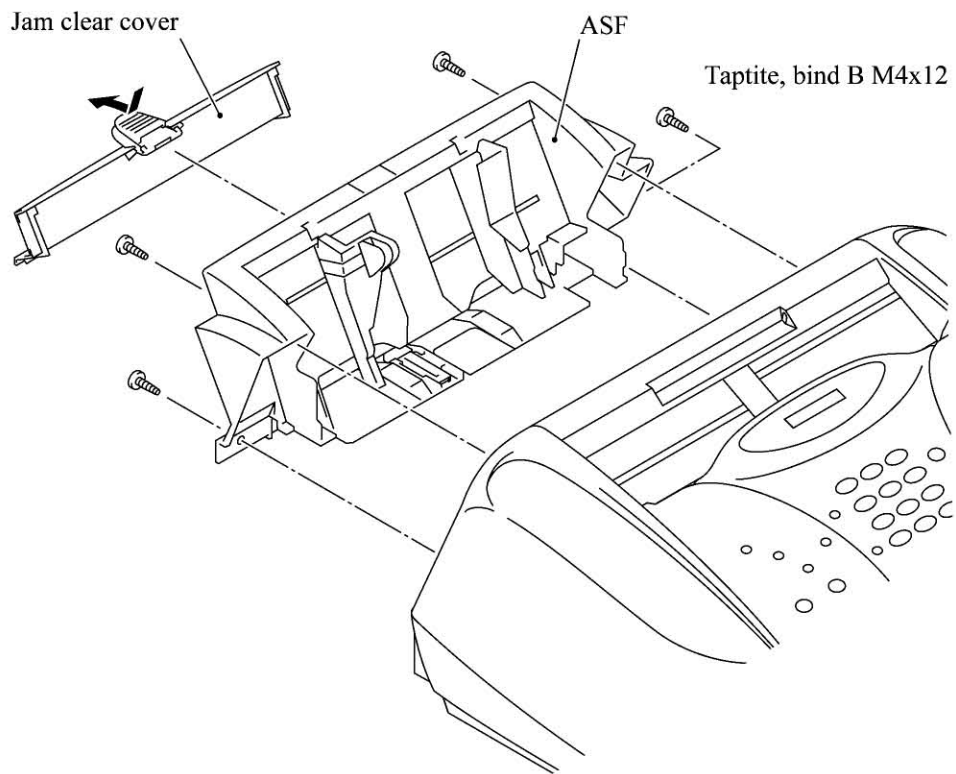

- (3) Pull out the separation pad ASSY.

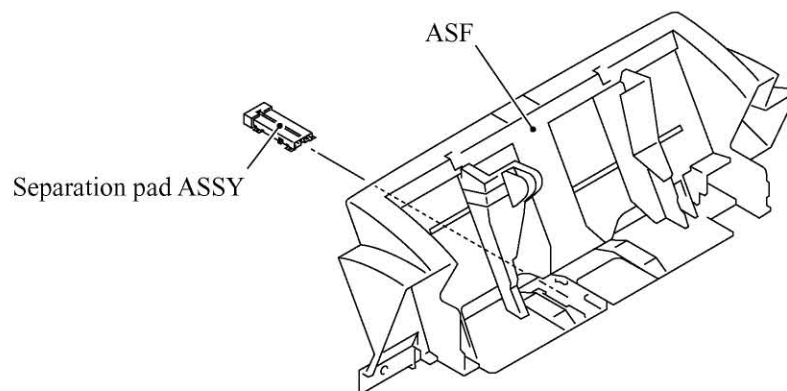

(4) Disassemble the separation pad ASSY as shown below.

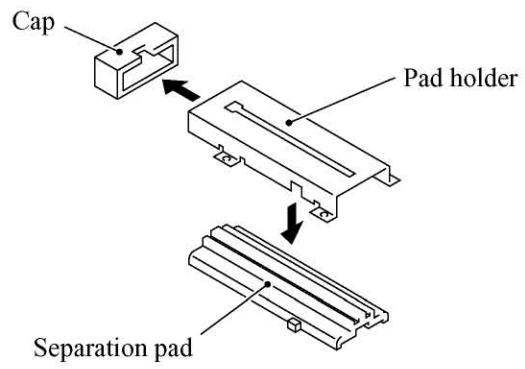

4.1.3 Bottom Plate, Ink Absorber Box, Main PCB, NCU PCB, and Power Supply PCB

(1) Disconnect the following harnesses and flat cables from the main PCB:

- Head flat cables
- Registration sensor harness
- Purge switch harness
- Ink empty sensor harness
- Panel-main harness
- CIS harness
- Scanner motor harness
- Carriage motor harness
- Paper feed motor harness
- Speaker harness*
- Hook switch harness*

*Provided in the FAX1800C.

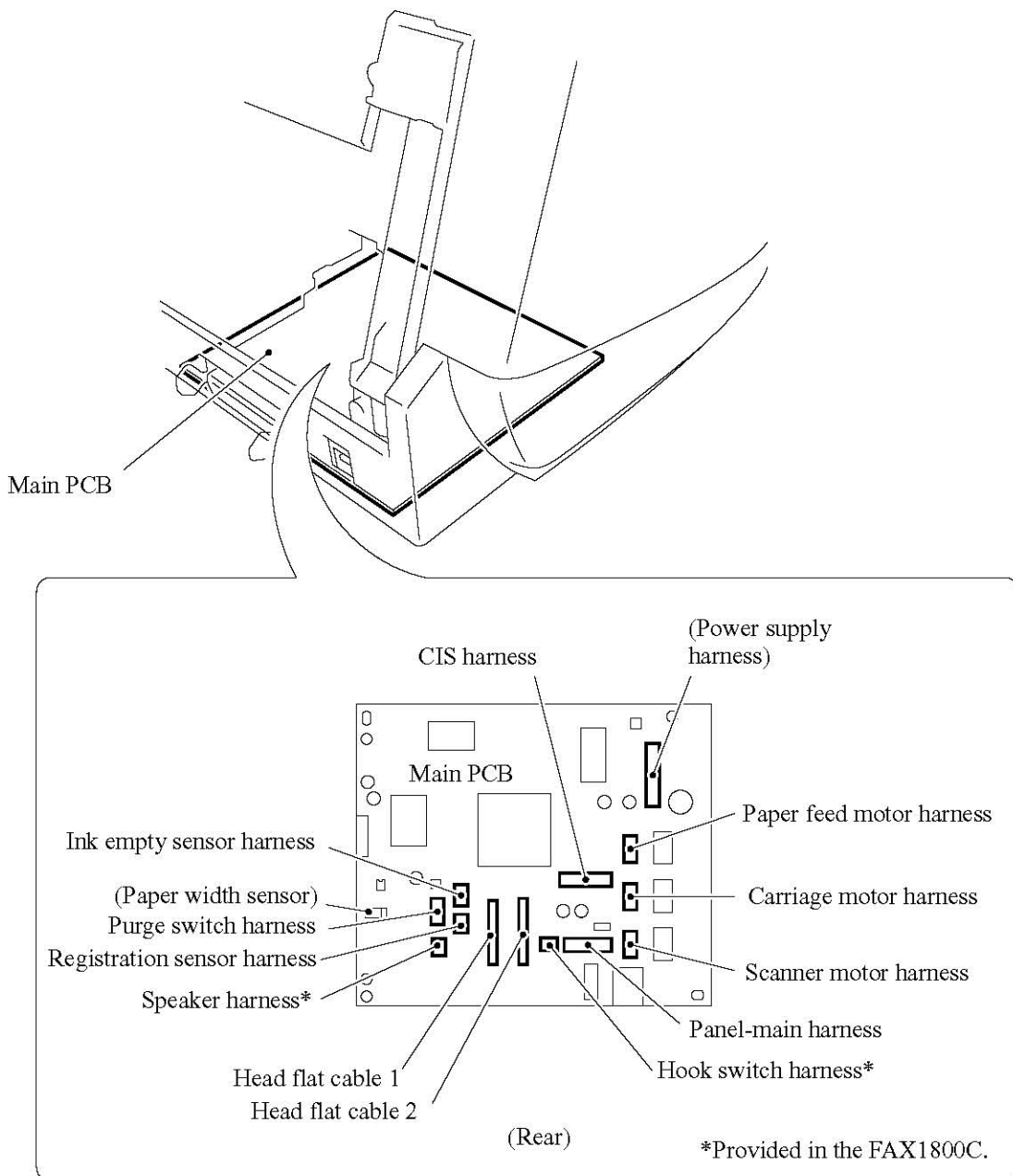

- (2) Remove three screws "e" from the rear of the machine (two for the parallel I/F connector and one for the USB I/F connector).
- (3) Turn the machine upside down.

NOTE: Cover the workbench with cloth to protect the top cover and control panel from scratches or damages.
- (4) Remove nine screws "a" from the bottom plate.
- (5) Remove screw "b" from the grounding terminal.
- (6) Remove four screws, two "c" and two "d" from the bottom shield.

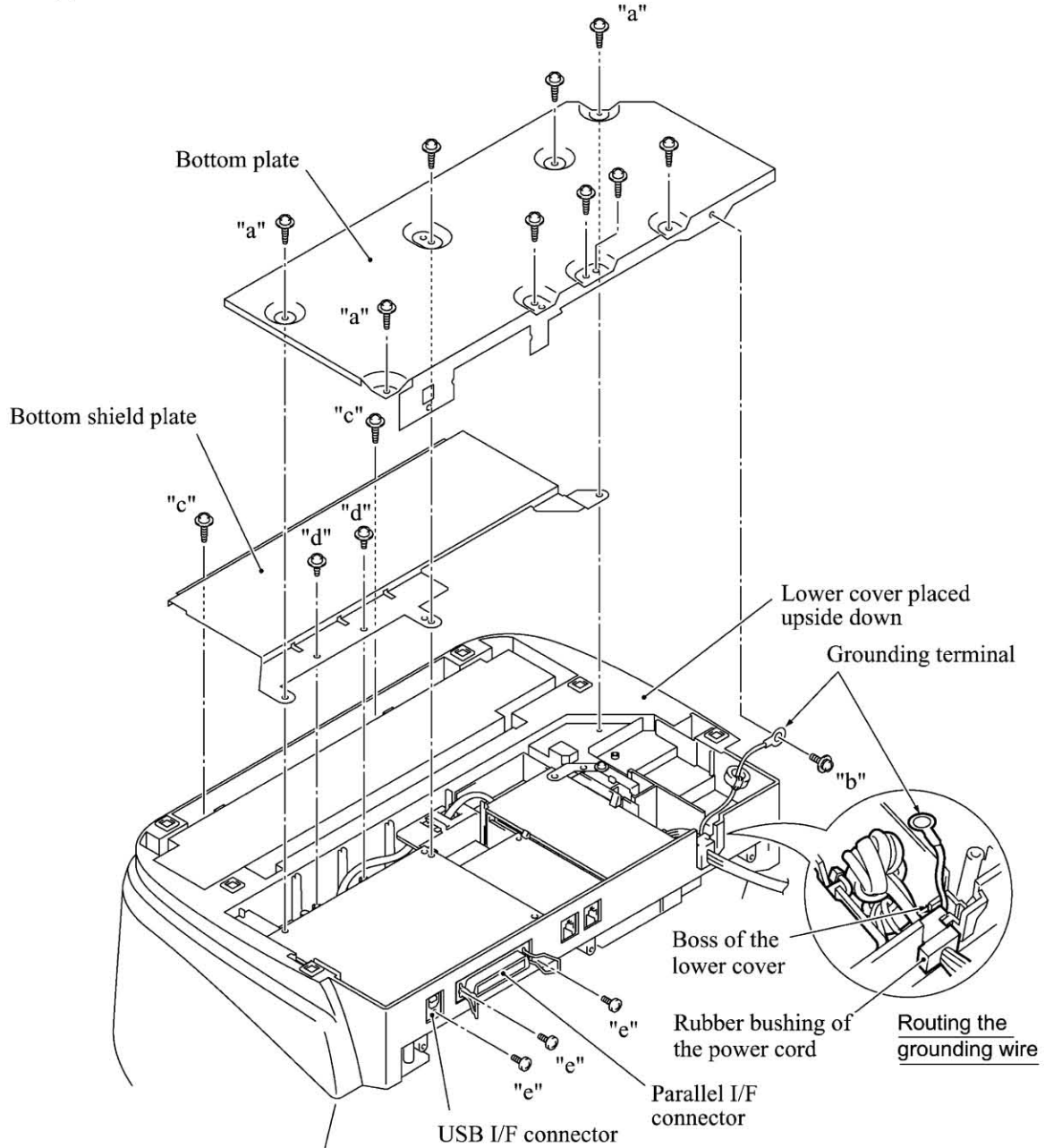

"a" and "c": Taptite, cup B M3x12
 "b": Screw, pan M4x8
 "d": Taptite, cup S M3x5
 "e": Screw, pan M3x6

(7) Push down the latch and remove the ink absorber box as illustrated below.

NOTE: Do not remove the ink absorber box unless it requires replacement. When replacing it, set a new one soon after the removal to prevent the machine from getting stained with drained ink.

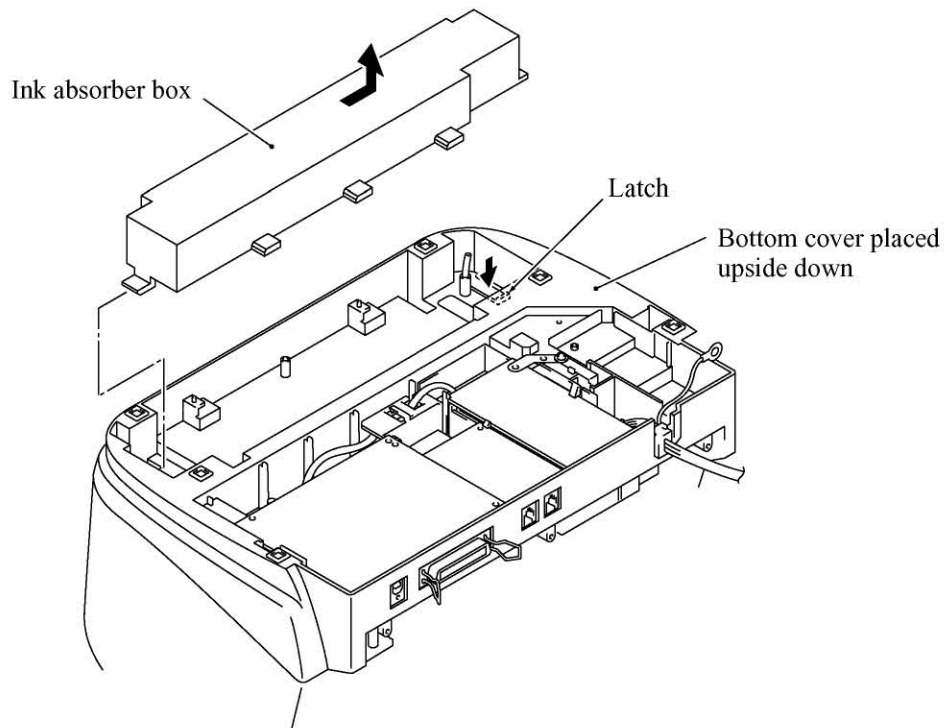

NOTE: If the print head unit is replaced with a new one, replace also the ink absorber box with new one.

NOTE: If the ink absorber box or the surrounding parts are stained with ink, wipe them with a waste cloth.

- (8) Remove the screw from the FG plate R.
- (9) Slightly pull up the FG plate R, pull two latches "a" outwards, and then lift up the power supply PCB. Disconnect the power supply harness from the PCB.
- (10) Slightly pull up the FG plate L and release the main PCB from it. Release the NCU PCB from latch "b" and disconnect it from the main PCB.
- (11) Disconnect the power supply harness from the main PCB.

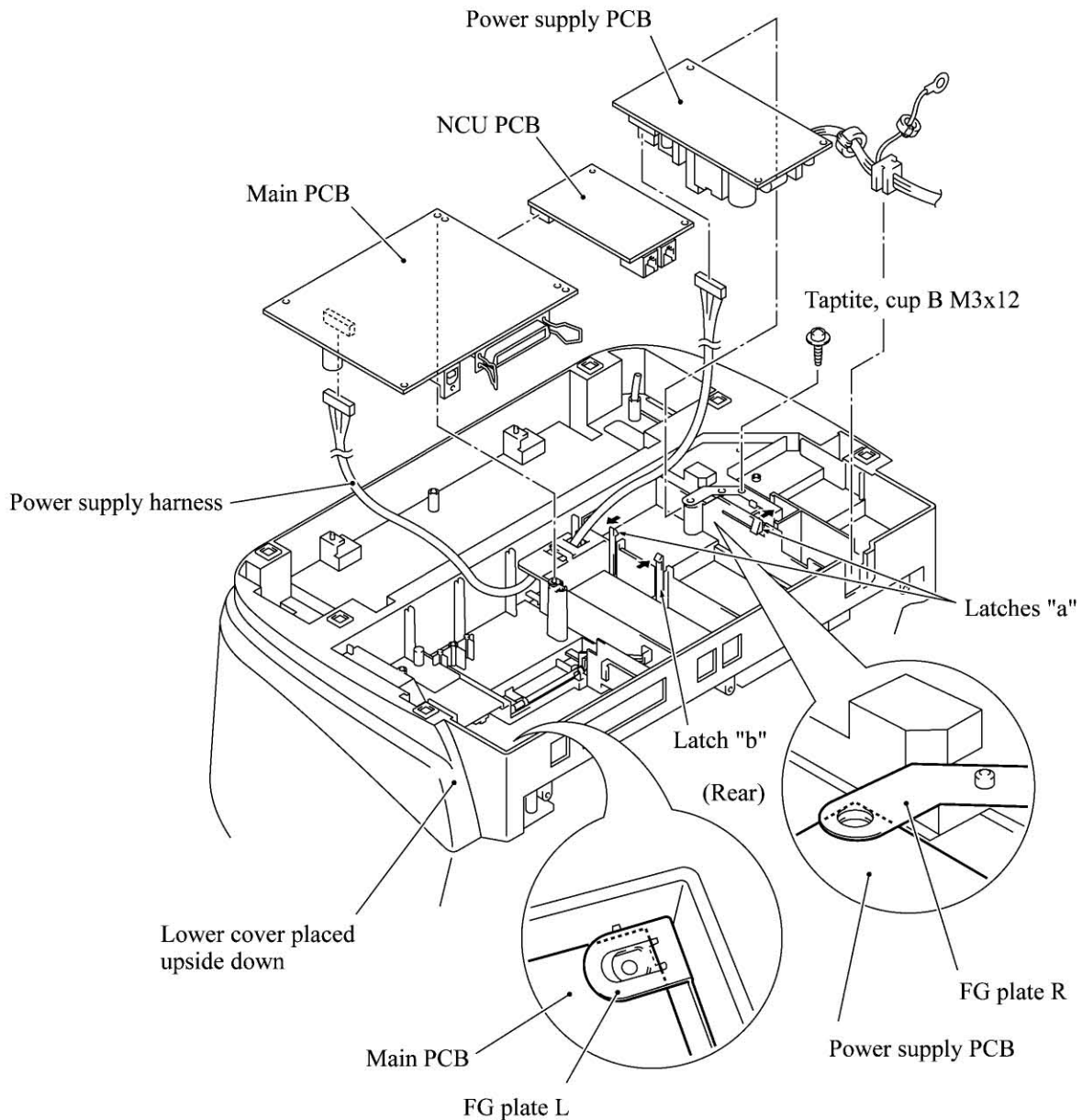

■ Reassembling Notes

- Be sure to route the power supply harness as illustrated above. Route the other harnesses and flat cables as illustrated in Subsection 4.1.22, "Harness Routing A." At the right rear corner, be sure to hook the ferrite core of the scanner motor harness on the cable guide.
- After you replace the main PCB, be sure to follow the flowchart given on the next page.
- Be sure to route the grounding wire as illustrated on page 4-12.

Setting up the main PCB after replacement

Important

NOTE: Before starting the following procedure, make sure that the print head unit is installed.

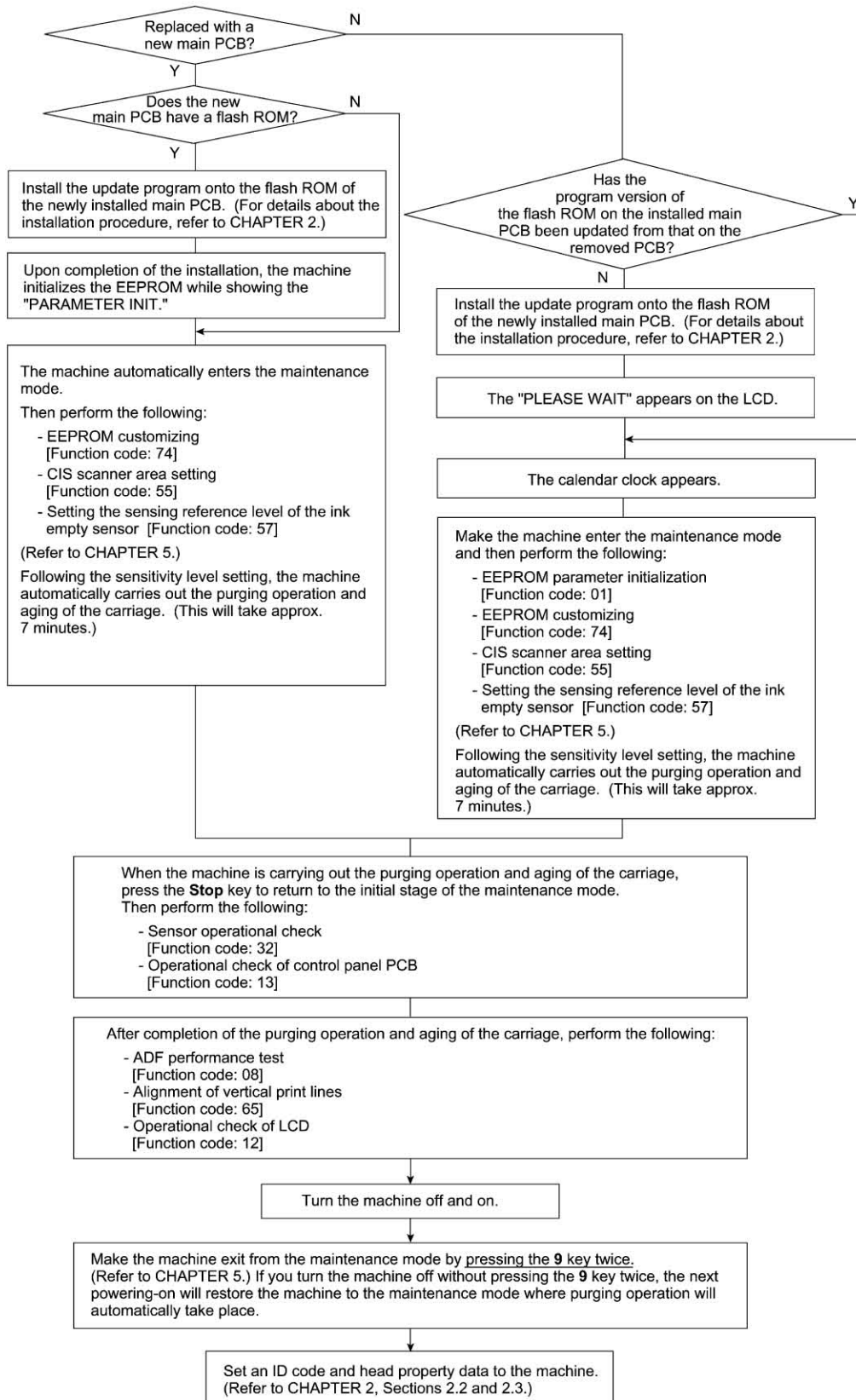

4.1.4 Enclosure Cover and Paper Width Sensor Actuator

- (1) While pulling up the FG plate R, lift up the enclosure cover.
- (2) Slightly push down the locking arm and remove the paper width sensor actuator as shown below.

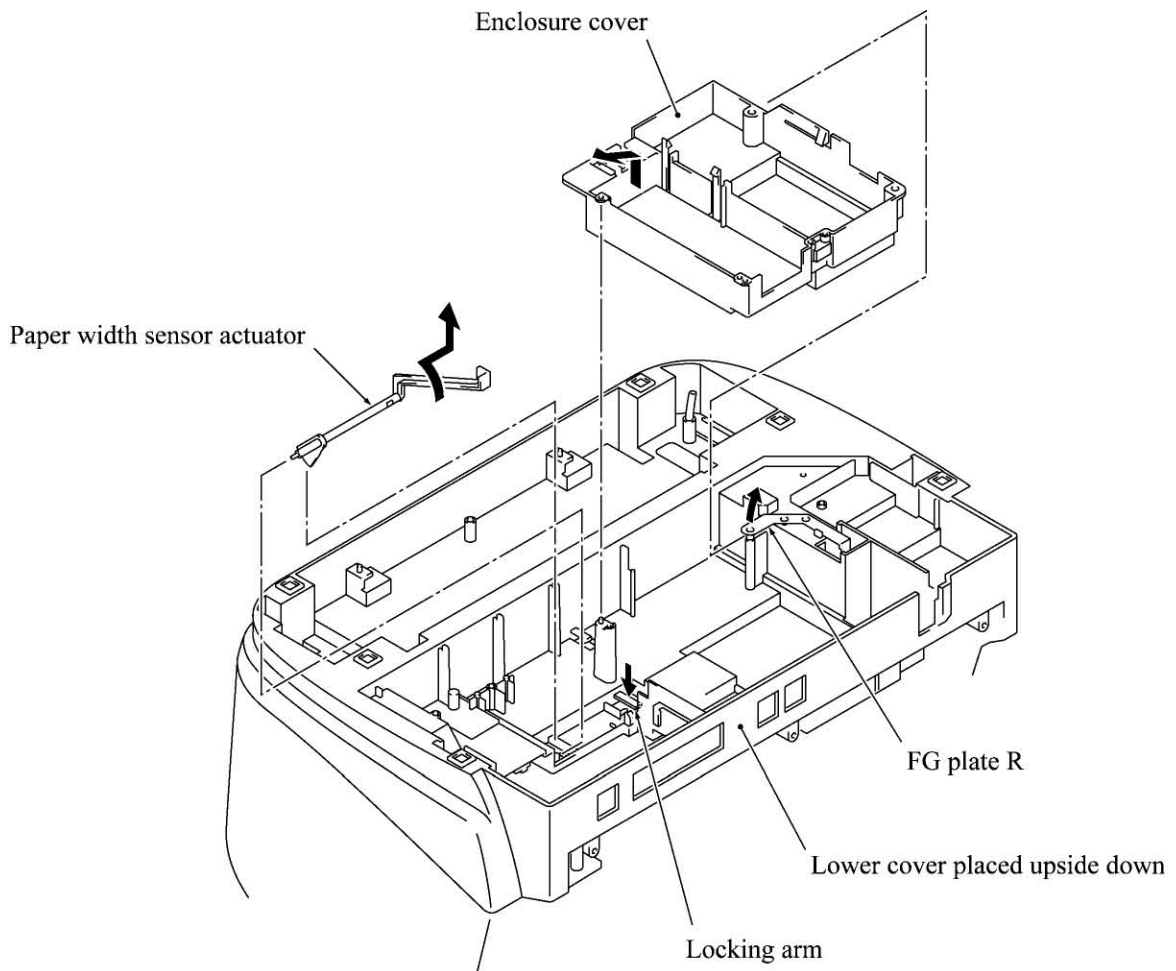

4.1.5 Top Cover

- (1) Turn the machine back to the normal position.
- (2) Open the control panel ASSY.
- (3) Open the top cover (not fully) and lift it up and to the rear.

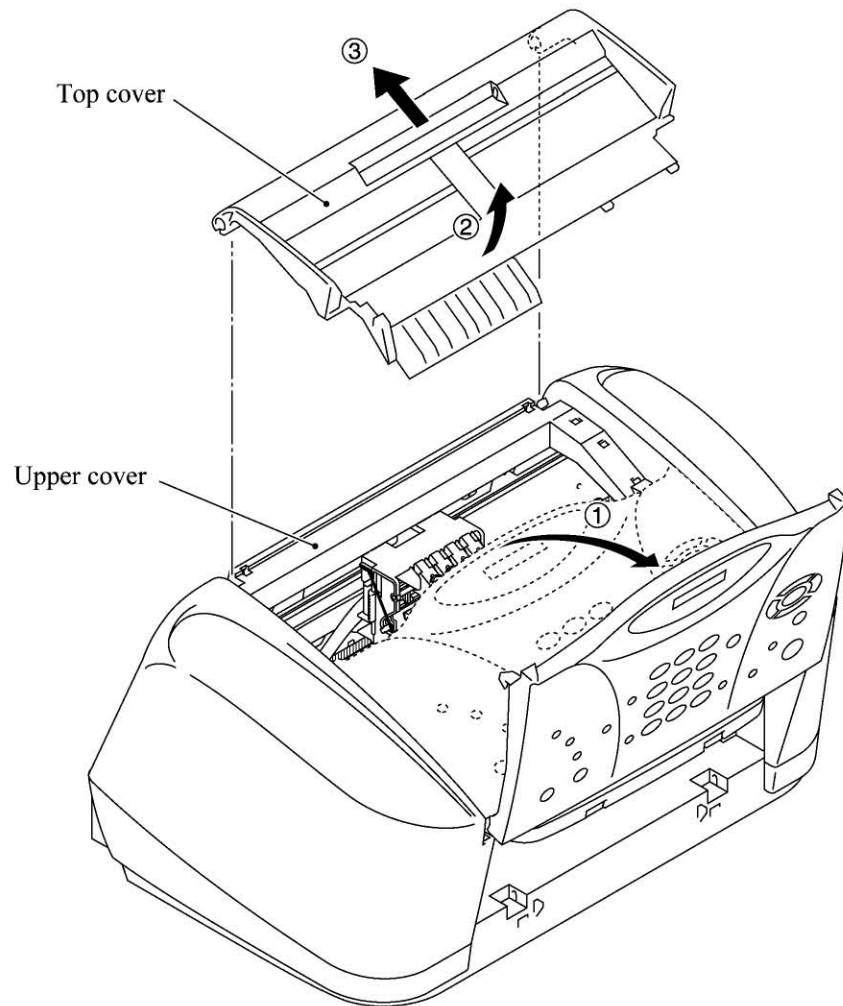

4.1.6 Control Panel ASSY

- (1) Open the control panel ASSY to you (in the direction of arrow ①).
- (2) Push the right and left arms of the control panel ASSY outwards (arrow ②) to release those arms from bosses "X" provided on the upper cover with a flat screwdriver.
- (3) Open the control panel ASSY further, then take out the panel-main harness from the harness guides provided on the panel rear cover and disconnect the panel-main harness from the control panel PCB.

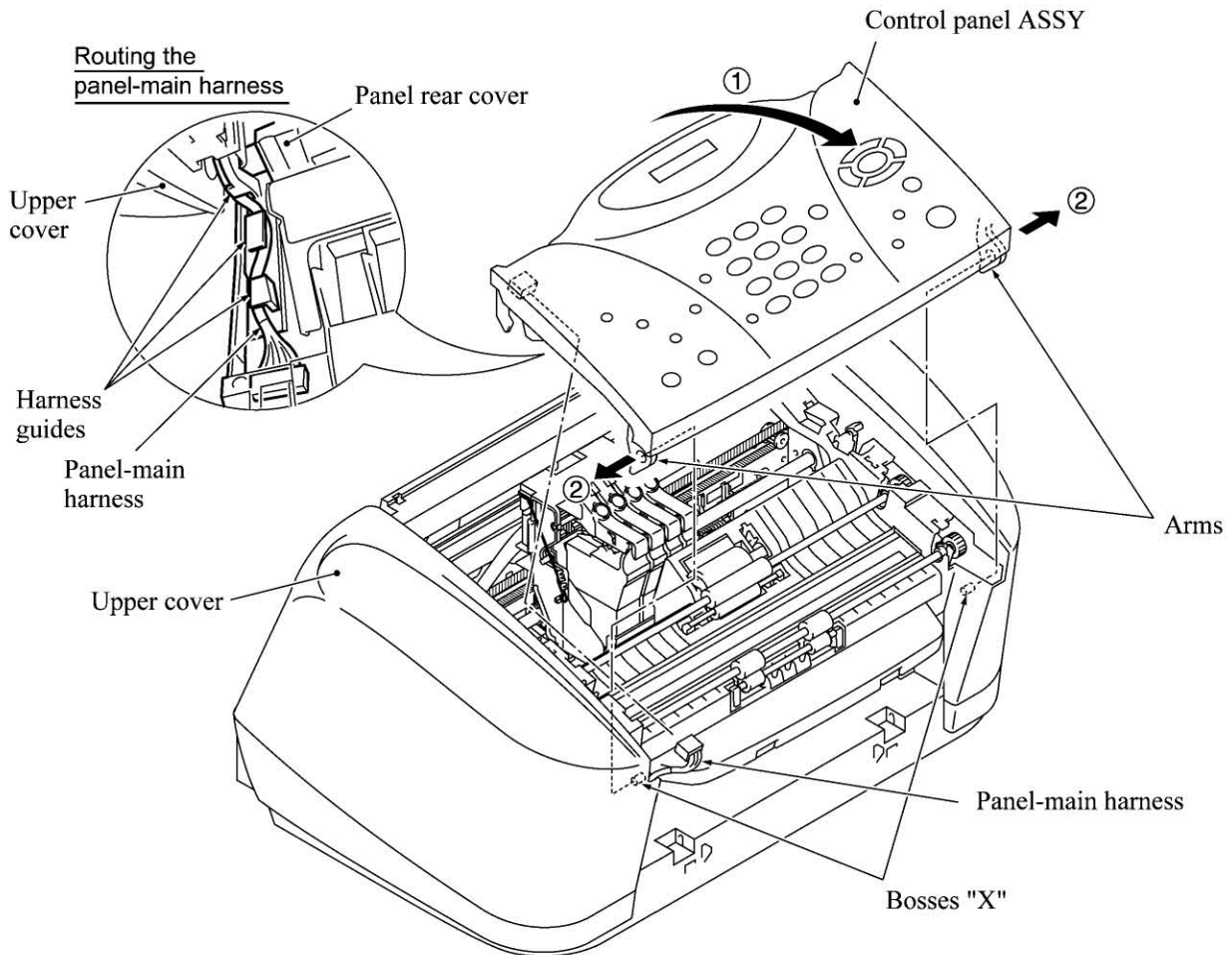

■ Reassembling Notes

- Route the panel-main harness along the three harness guides as illustrated above.

4.1.7 Panel Rear Cover and Control Panel

- (1) Place the control panel ASSY upside down.

If you do not need to remove the ADF parts, antistatic brush, or document rear sensor actuator, skip to step (5).

- (2) To remove the ADF parts (spring plates and separation rubber), remove the screw.
- (3) To replace the antistatic brush, peel it off.

NOTE: Once removed, it will become unusable and a new part will have to be put back in.

- (4) To remove the document rear sensor actuator, pull the actuator to the left and lift up the right end of the actuator.
- (5) Pull section "b" of the panel rear cover to the front to release the center tab of the document pressure bar, turn up the document pressure bar, and pull either end of the document pressure bar outwards to release it.

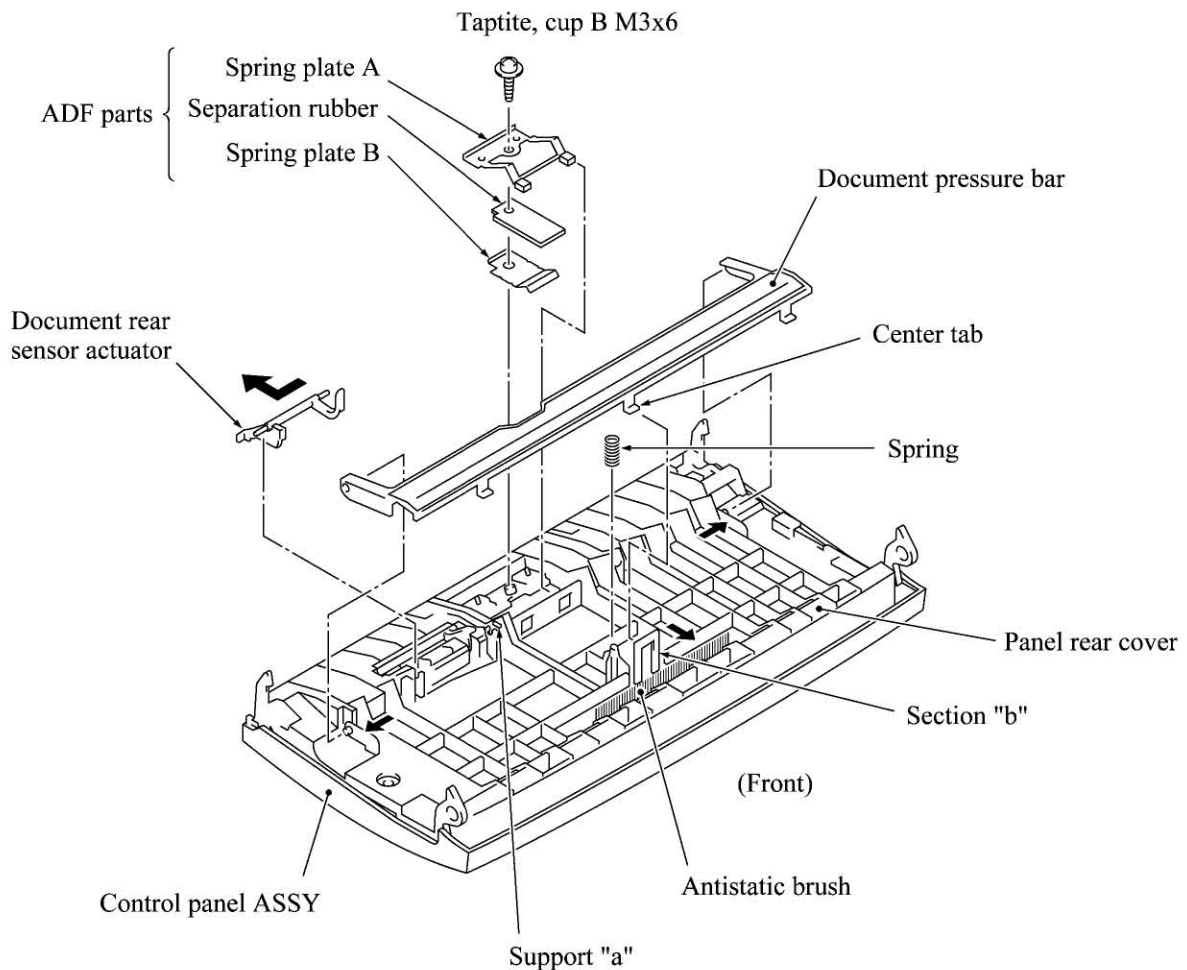

- (6) Remove the two screws from the panel rear cover.
- (7) Unhook the panel rear cover from ten "X" latches provided on the control panel and lift up the panel rear cover.
- (8) Fully turn the document front sensor actuator to the rear and lift it up.
- (9) Unhook the control panel PCB from seven "Y" latches.
- (10) Slightly lift up the control panel PCB, then unlock the LCD cable connector and disconnect the LCD flat cable. Next, unlock the FPC key connector and disconnect the FPC key.

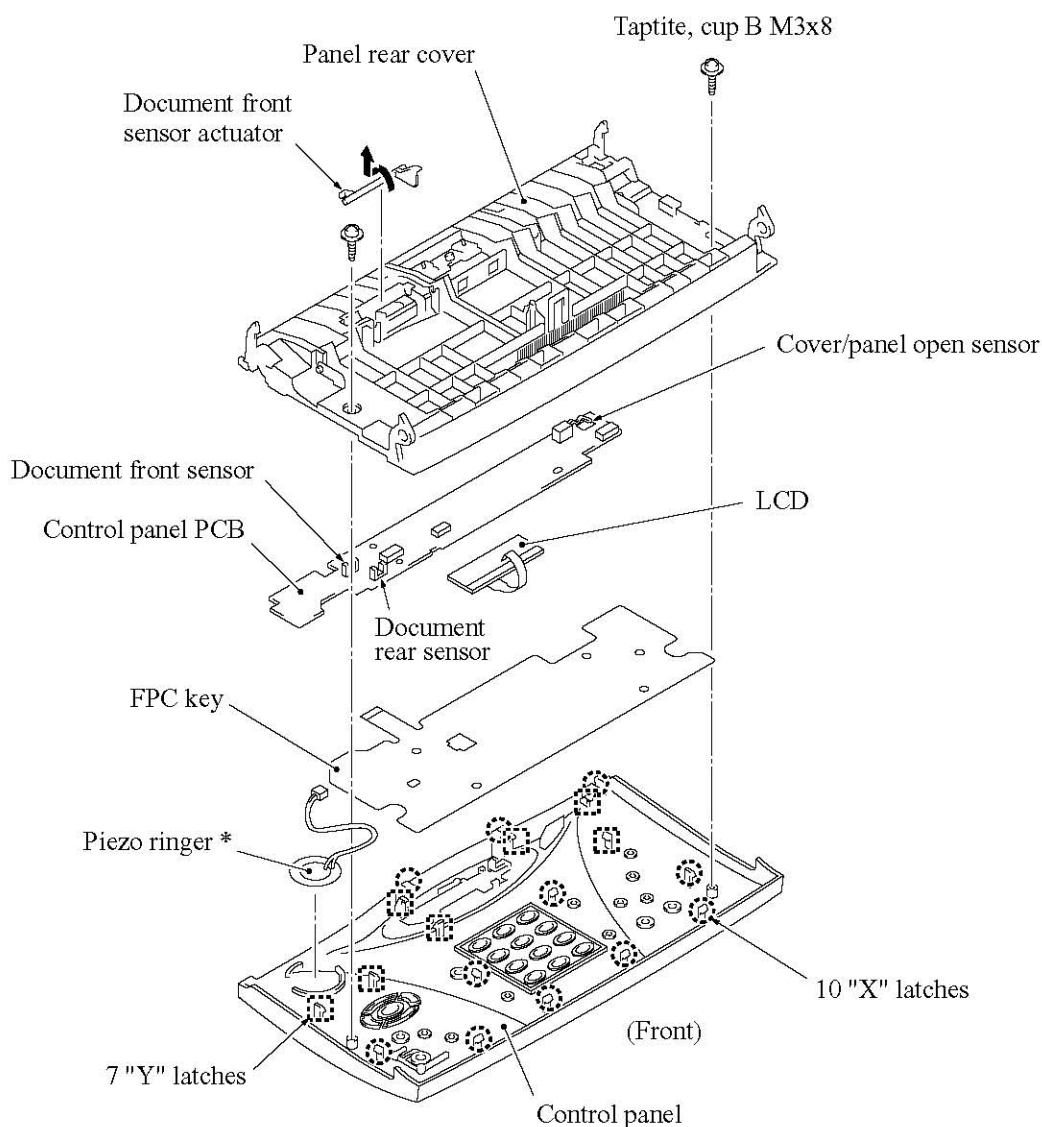

* Not provided in the FAX1800C.

(11) As shown below, pull up the locking arm "x," slide the LCD to the right, pull the locking arm "y" to the rear, and take out the LCD while pulling the LCD flat cable gently.

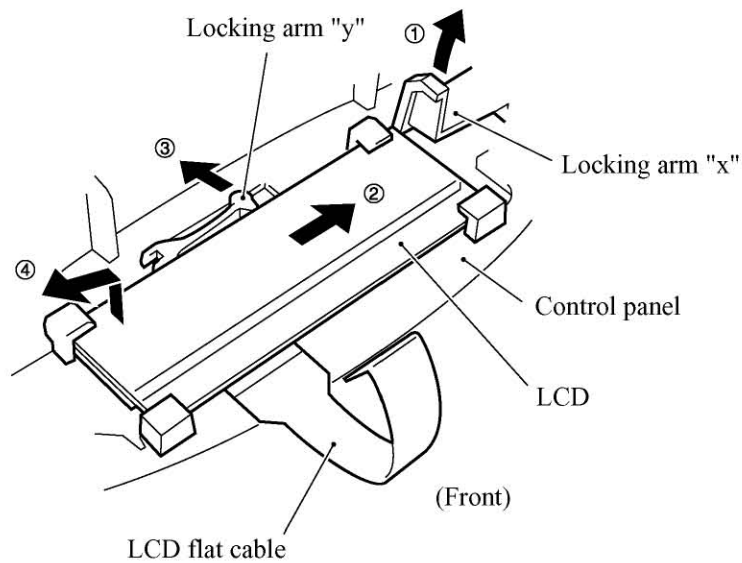

■ Reassembling Notes

- Before reinstalling the LCD to the control panel, wipe fingerprints or dust off the LCD surface and control panel window with a soft cloth.
- A new LCD is covered with a protection sheet. Before installing it, remove the protection sheet.

4.1.8 CIS Unit

- (1) Remove the screw from the CIS side spring and lift it up.
- (2) Move the CIS unit to the left and lift up the right edge of the CIS unit. While holding up the CIS unit, disconnect the CIS harness. The CIS springs also come off.

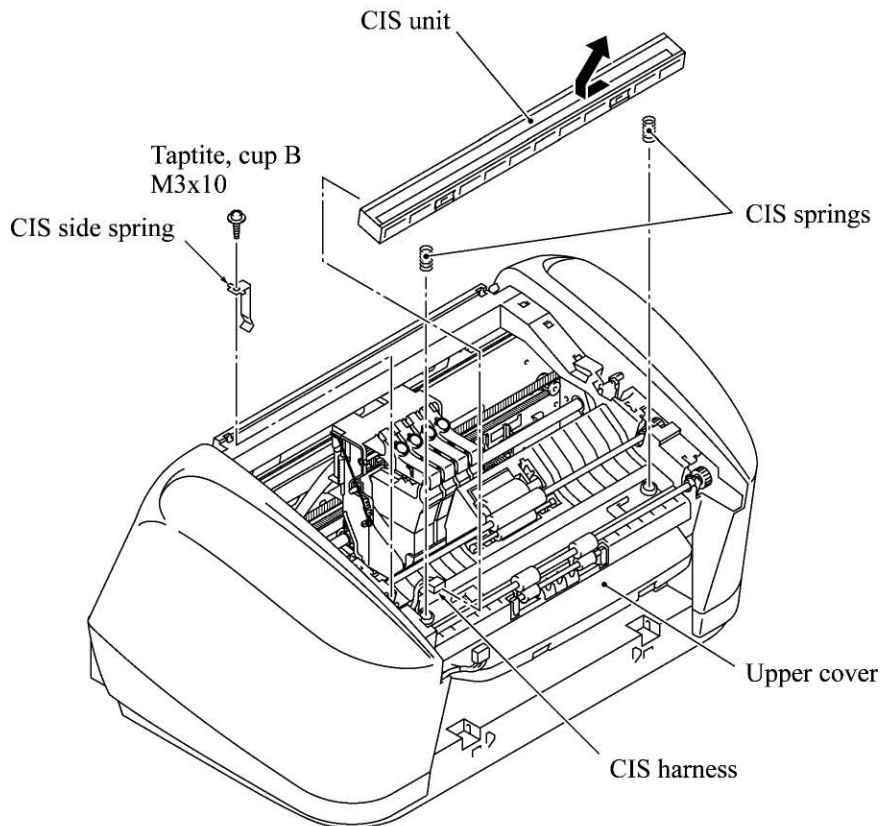

■ Reassembling Notes

- After installation of the CIS unit, wipe fingerprints or dust off the CIS surface with a soft cloth.

4.1.9 Upper Cover

- (1) Remove the two screws from the upper cover.
- (2) Disconnect the panel-main harness and CIS harness from the main PCB if you have not removed the main PCB.
- (3) Disconnect the scanner motor harness from the main PCB if you have not removed the main PCB.

Remove the harness from the four cable guides (shown in Subsection 4.1.22 "Harness routing A.")

- (4) Press the cover retainers R inwards with the tip of a flat screwdriver to release the rear hooks provided on the inside of the upper cover.
- (5) Lift up the upper cover while releasing the front hooks from the cover retainers F.

CAUTION: After removing the upper cover, do not turn the machine upside down. The main chassis may be warped or distorted so that the print quality could deteriorate.

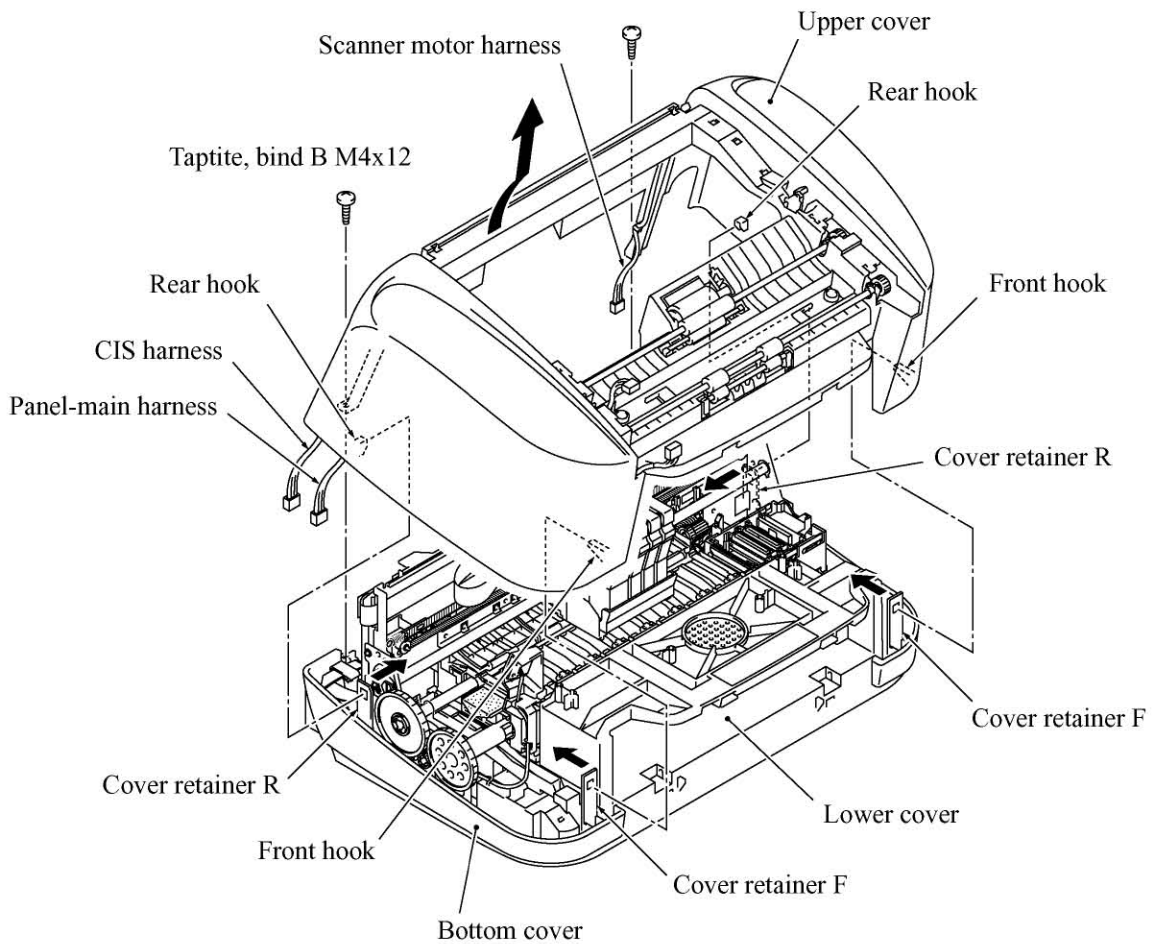

■ Reassembling Notes

- Before installing the upper cover, make sure that the panel-main harness, CIS harness, and scanner motor harness are routed properly on the inside of the upper cover. (Refer to Subsection 4.1.22 "Harness Routing B" and "Harness Routing C.")
- When installing the upper cover, take care not to bring the tab of the ASF roller unit inside the upper cover. The tab should be fitted to the rear edge of the upper cover as illustrated below.

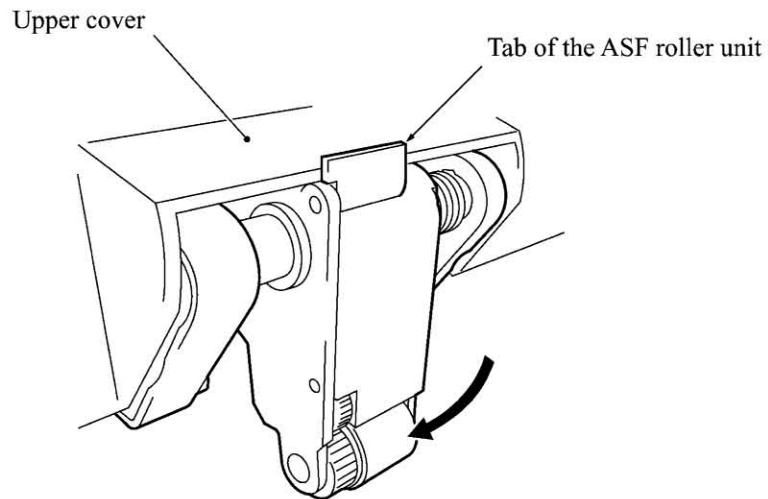

4.1.10 Document Feed Roller ASSY, Document Ejection Roller ASSY, Pressure Roller, and Pinch Rollers

- (1) Remove the two pawled plastic bushings from the left ends of the document feed roller and document ejection roller. (Access those bushings from the inside of the upper cover.)
Move the document feed roller and document ejection roller to the right and upwards.
- (2) Push two latches "a" to the rear and remove the pressure roller, its shaft and springs.
- (3) Push two latches "b" to the front and remove the pinch rollers, their shaft and spring.

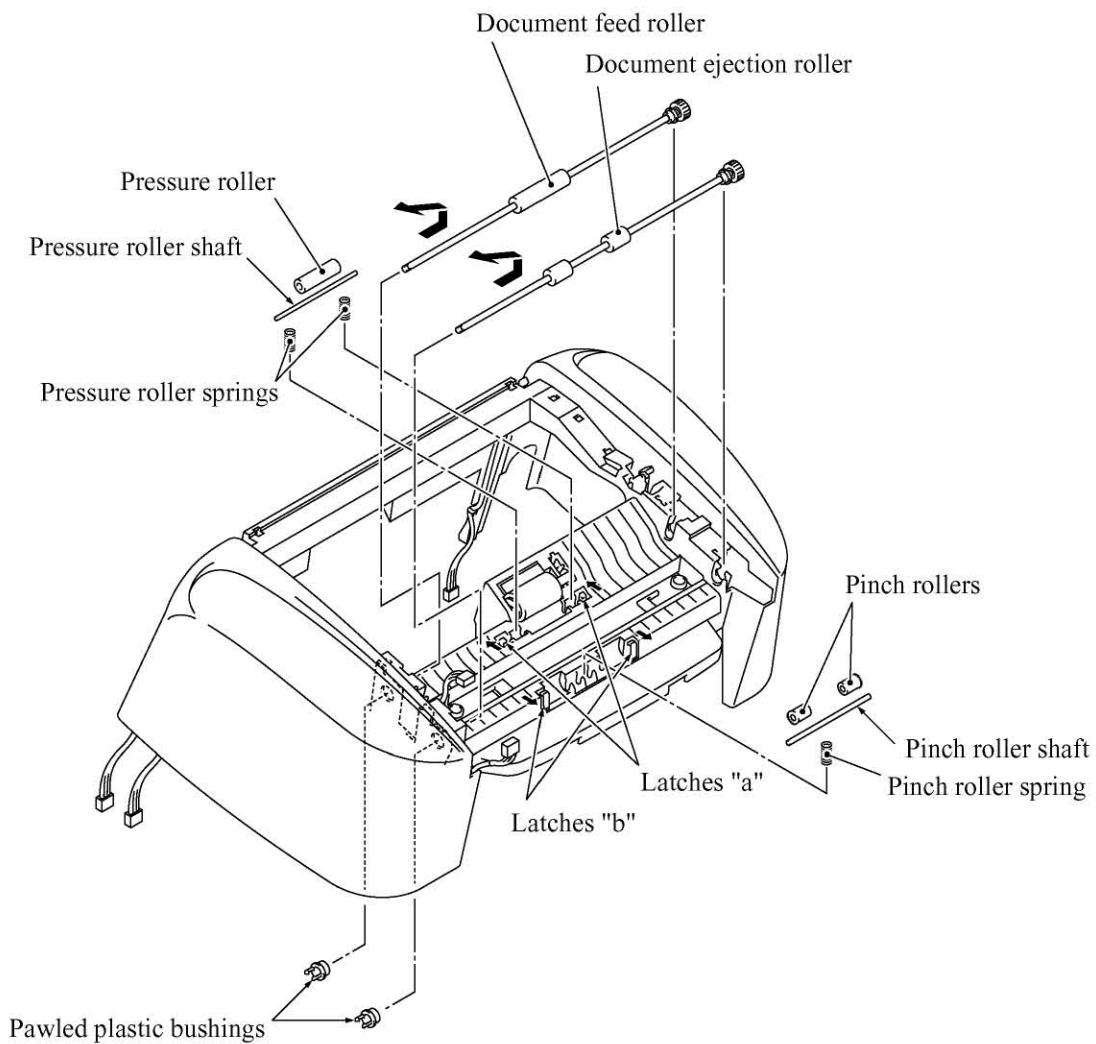

4.1.11 Panel Lock Springs, Scanner Chassis, Separation Roller, Scanner Drive Unit, and Scanner Motor

- (1) Remove screws "a" and "b" from the panel lock springs R and L, respectively, then take those springs out of the upper cover. (Access them from the inside of the upper cover.)
- (2) Remove the scanner motor harness from the cable guides provided on the inside of the upper cover (see Subsection 4.1.22, "Harness Routing B.")
- (3) Remove four screws "c" from the scanner chassis and take it out.
- (4) Remove the CIS front springs.

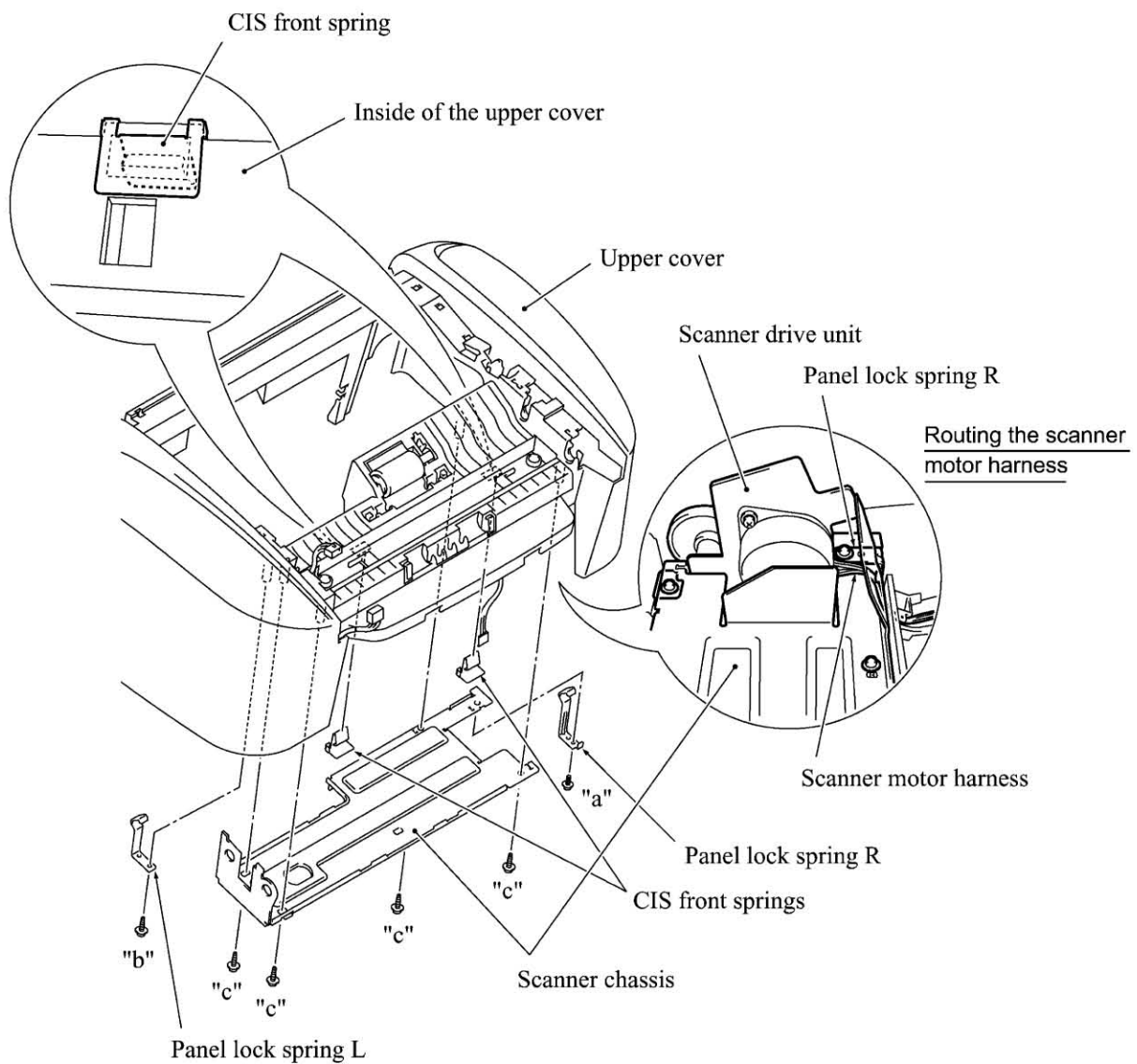

"a": Taptite, cup S M3x5
 "b" and "c": Taptite, cup B M3x10

- (5) Press the lock arm to the rear and move the separation roller gear.
 Press the lock arm again to remove bushing 12. Then the separation roller and bushing 6.
 (Access them from the inside of the upper cover.)
- (6) Lift up the scanner drive unit together with the separation roller gear.

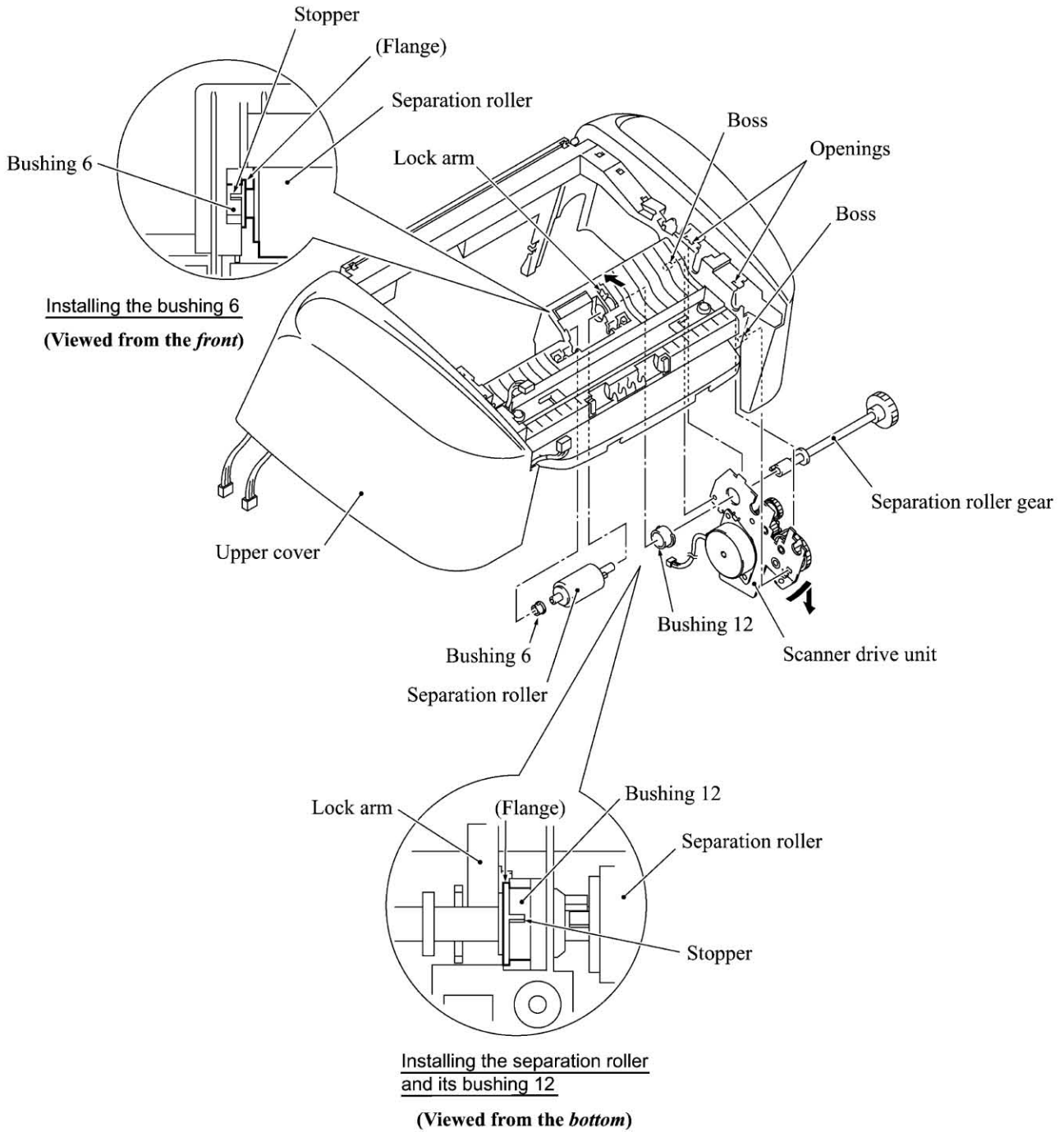

- (7) Remove the screw and release the scanner motor from the scanner drive unit.

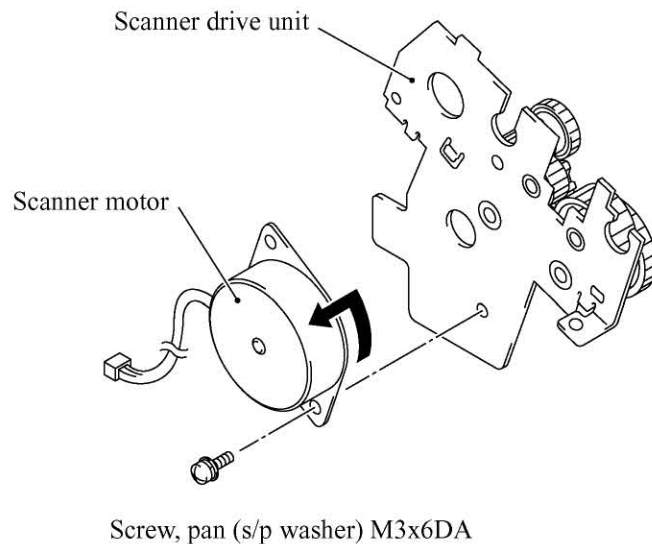

■ Reassembling Notes

- When securing the scanner motor to the scanner drive unit, face the motor connector as shown above.
- When setting the separation roller and its gear, first fit bushing 6 into the upper cover with its flange facing towards the scanner drive unit and with its stopper facing down (when viewed from the bottom), as illustrated on the previous page.
Set the separation roller. Then lightly press the lock arm and fit bushing 12 with its flange facing towards the scanner drive unit and with its stopper facing up (when viewed from the bottom).
Next, insert the separation roller gear shaft through bushing 12 and engage it with the separation roller.
- Route the scanner motor harness on the inside of the upper cover as shown in Subsection 4.1.22, "Harness Routing B."
- When reinstalling the scanner chassis, make sure that the scanner motor harness is routed as shown on page 4-26.

4.1.12 Purge Unit

- (1) Remove the print head unit (refer to Subsection 4.1.1).
- (2) Disconnect the purge switch harness (blue and white) from the main PCB if you have not removed the main PCB.

Remove the purge switch harness from the cable guides provided on the lower cover. (Refer to Subsection 4.1.22 "Harness Routing A.")

- (3) Remove the two screws, one from the right side and the other from the rear side of the purge unit.
- (4) Remove the drain tube from the tube guide and pull it out.

NOTE: Cover the end of the drain tube with a waste cloth to prevent drained ink from leaking out and making stains on the machine.

- (5) Pull the purge unit to the front in the direction of arrow ①. Then while pulling the right front end of the main chassis slightly (arrow ②), pull out the purge unit to the front (arrow ③).

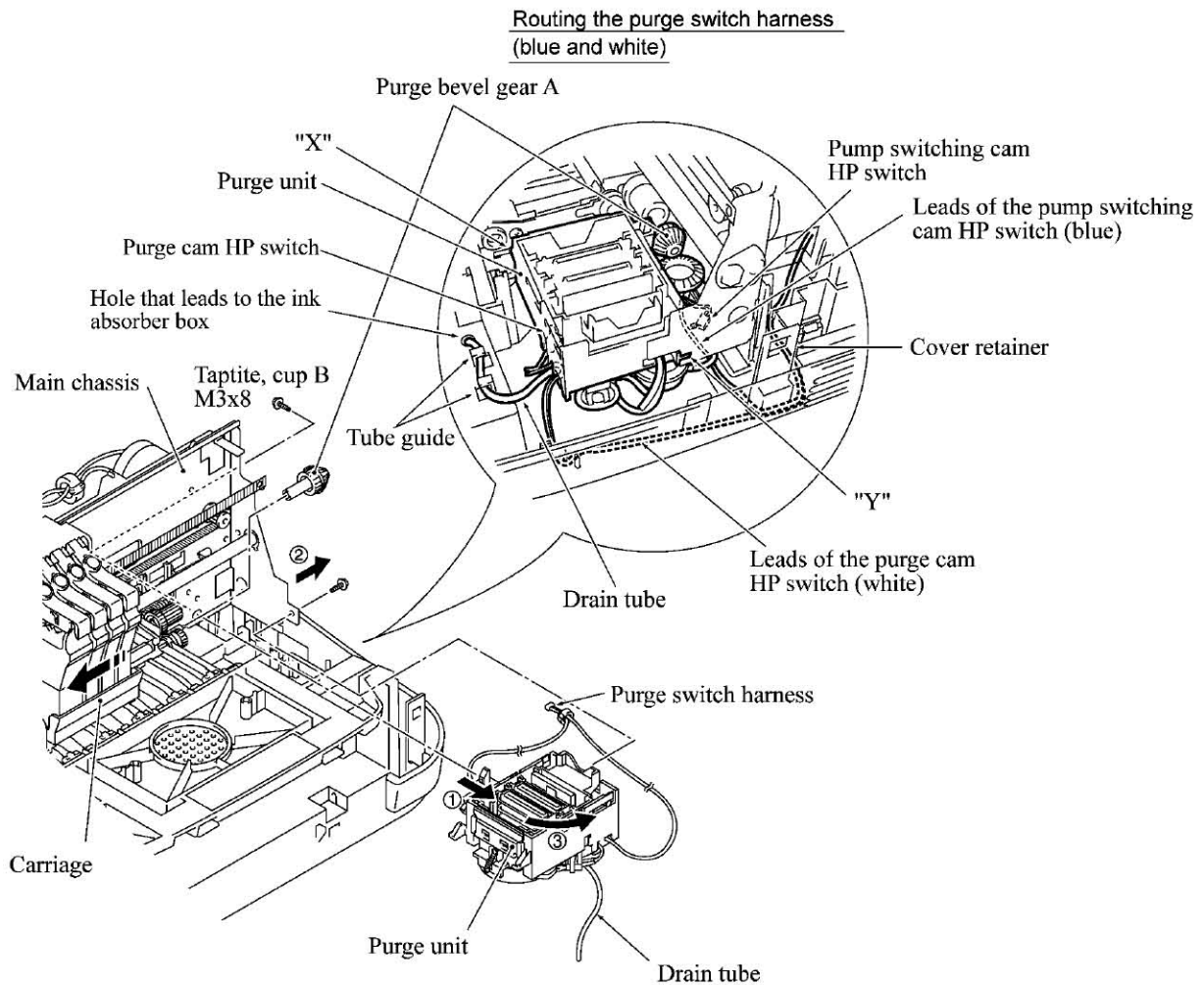

- (6) Take off the purge cam HP switch and pump switching cam HP switch from the purge unit by pulling the latches outwards, respectively.

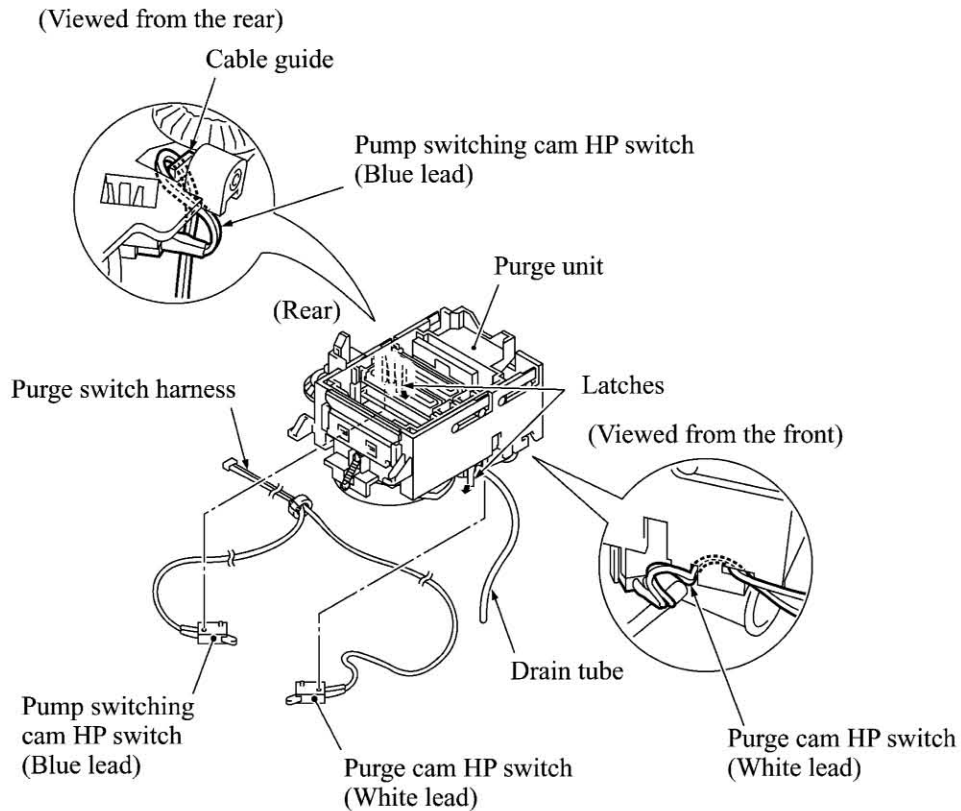

- (7) Remove the purge bevel gear A. (See the illustration given on the previous page.)

■ Reassembling Notes

- When installing the purge unit, be sure to insert the end of the drain tube into the hole (provided in the lower cover) that leads to the ink absorber box.

4.1.13 Main Chassis

- (1) Disconnect the carriage motor harness, registration sensor harness, ink empty sensor harness, head flat cables, and paper feed motor harness from the main PCB if you have not removed the main PCB.

Remove those harnesses from the cable guides provided on the lower cover.

- (2) Remove screw "x" from the lower end of FG plate R if you have not removed it on page 4-14.
- (3) Remove screws "y" and "z" from the upper ends of FG plates R and L, respectively, then remove those plates. Removing the FG plate L releases the head flat cables.
- (4) Unhook the four latches and lift up the main chassis.

NOTE: If vibration absorbers (black rubber bushings) are left in the lower cover, pull them out.

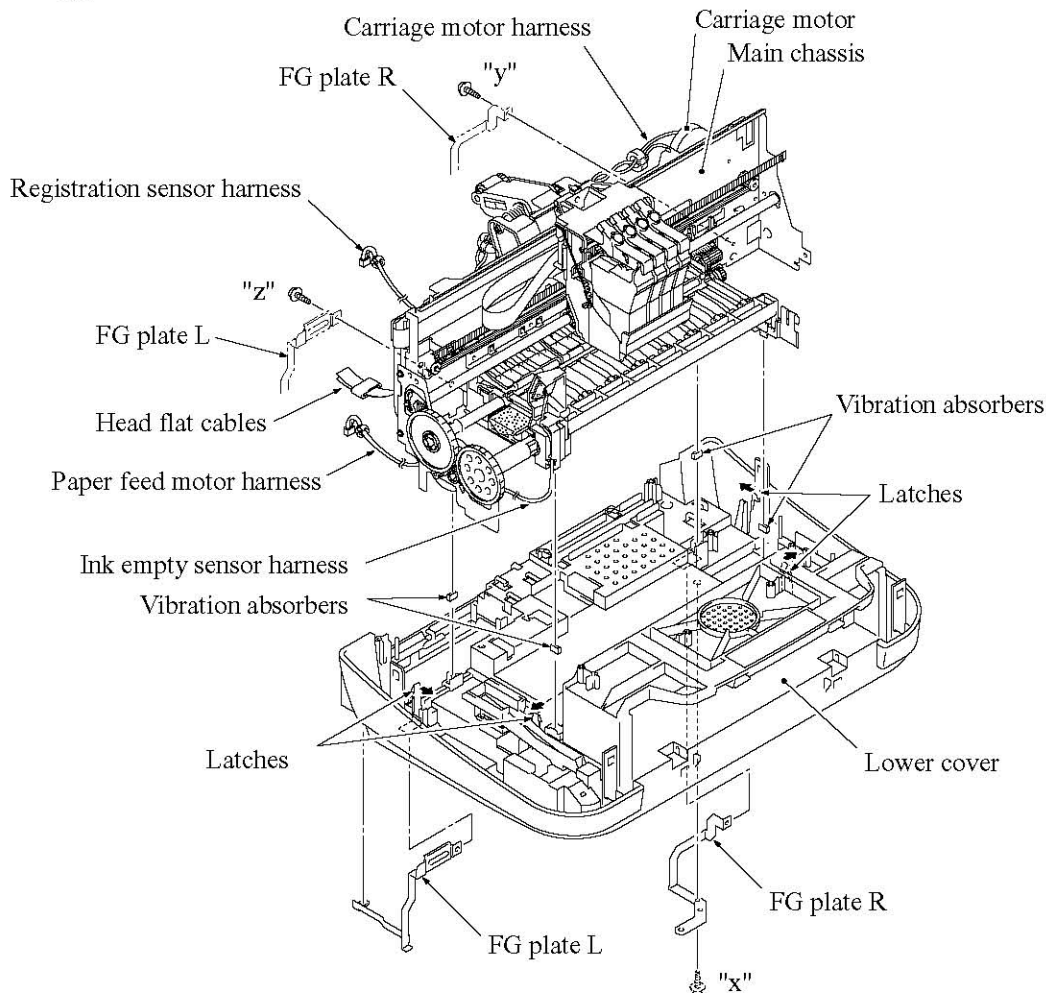

"x": Taptite, cup B M3x12

"y" and "z": Taptite, cup S M3x5

■ Reassembling Notes

- When installing the main chassis to the lower cover, make sure that the four vibration absorbers are fitted on the bottom ends of the main chassis.
- After installing the main chassis, be sure to route the harnesses and flat cables as illustrated in Subsection 4.1.22 "Harness Routing A."

4.1.14 ASF Roller Unit and its Related Gears

- (1) Remove the three screws from the rear of the ASF.
- (2) Move the ASF to the left and remove it to the rear.
- (3) Remove the gear 31MF by pulling its pawls outwards. The gear shaft 17 and bushing also come off.

NOTE: Take care not to lose the bushing.

- (4) Remove gear 39 and gear 25 from the main chassis.

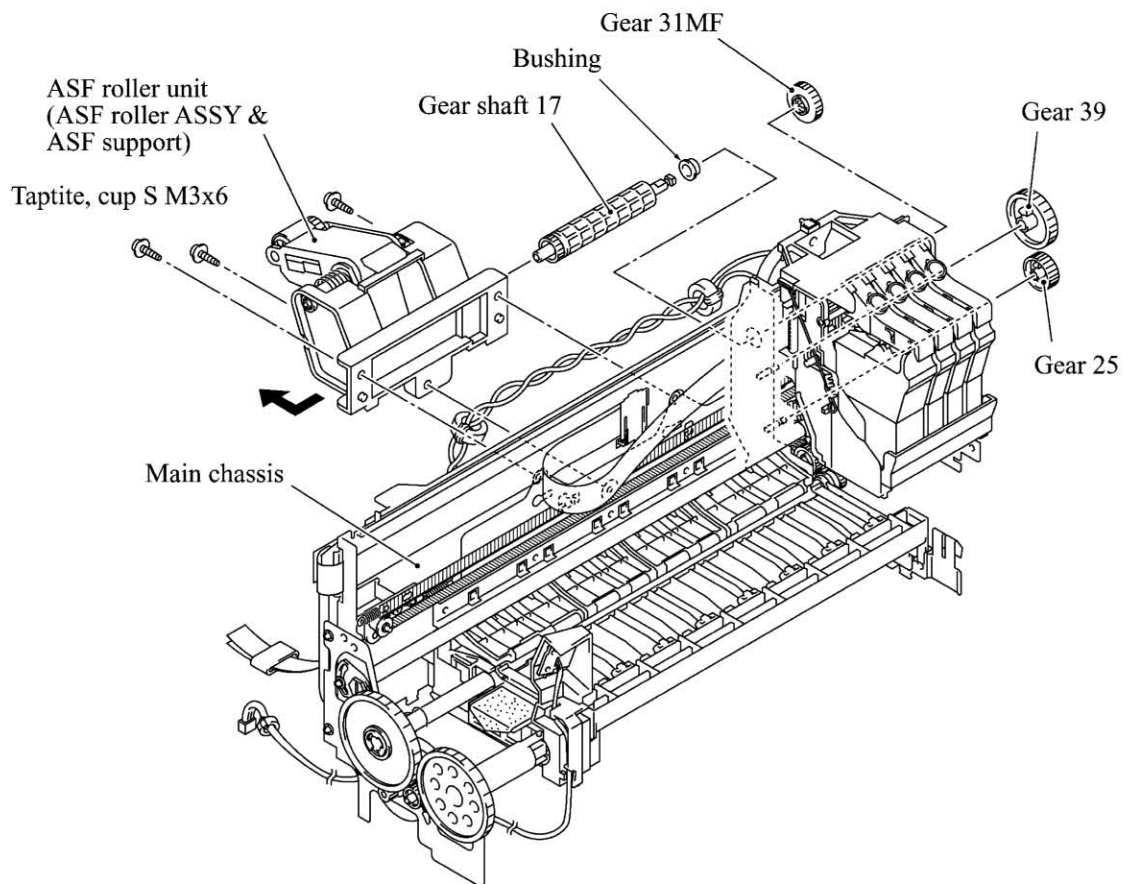

Disassembly of the ASF Roller Unit

- 1) Pull the pawl of the ASF gear 31 outwards and pull out the gear shaft 15. The ASF roller ASSY and the ASF gear 32 also come off.
- 2) Remove the screw from the ASF roller ASSY. Then it will be disassembled as shown below.

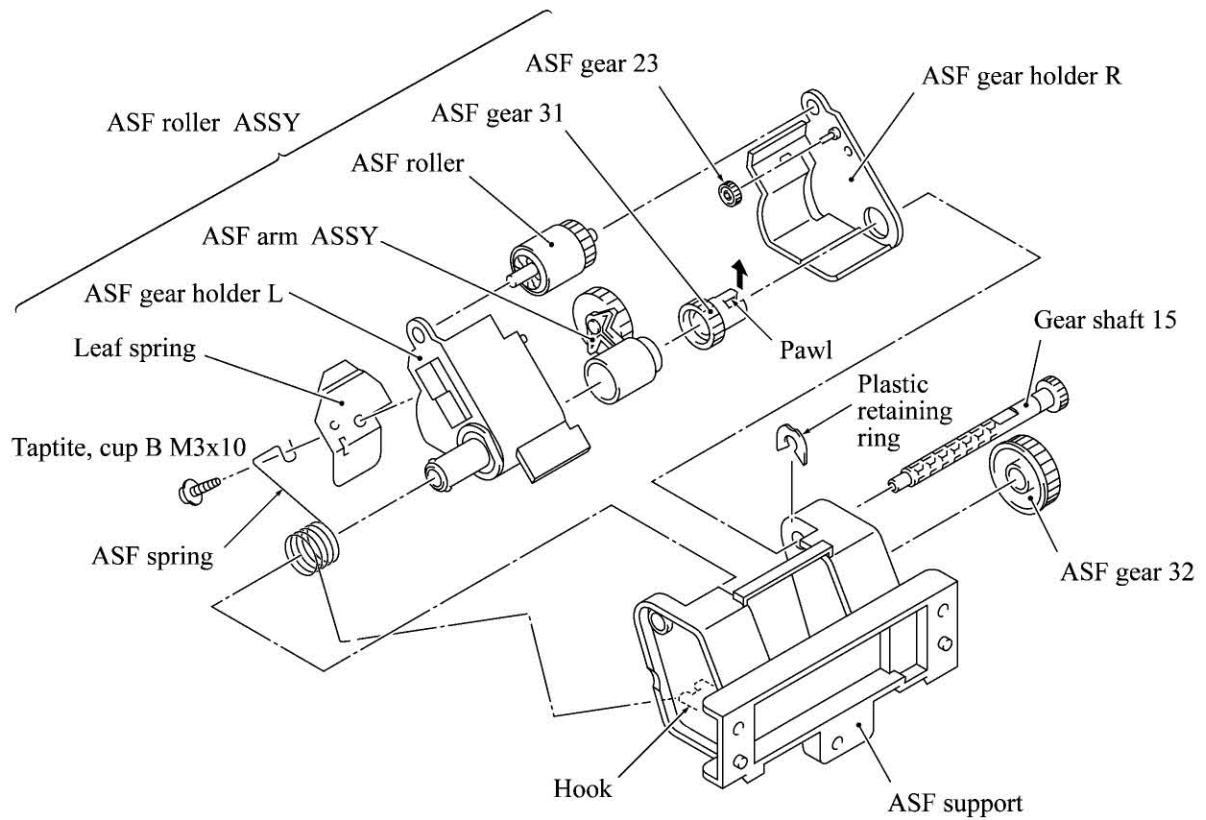

4.1.15 Roller Pressure Holders

- (1) At each of the paper pressure holders, unhook the top end of the spring from the main chassis.
- (2) Remove the roller pressure holders.

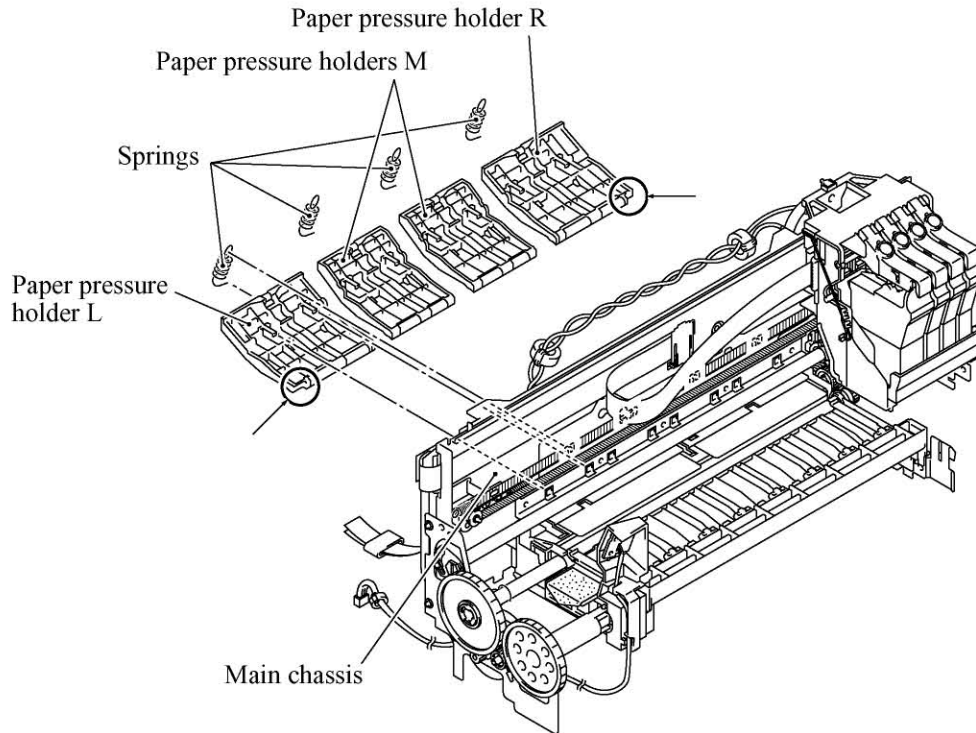

■ Reassembling Notes

- When replacing films on the paper pressure holders with new ones, attach them as illustrated below.

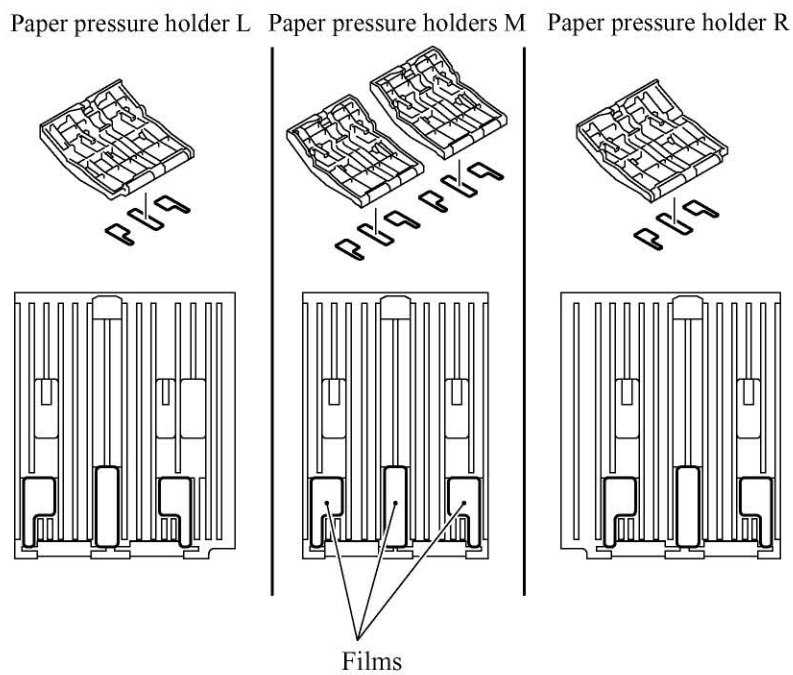

4.1.16 Paper Chute and Registration Sensor

- (1) Remove the screw from the rear of the paper chute and take it off from the main chassis.

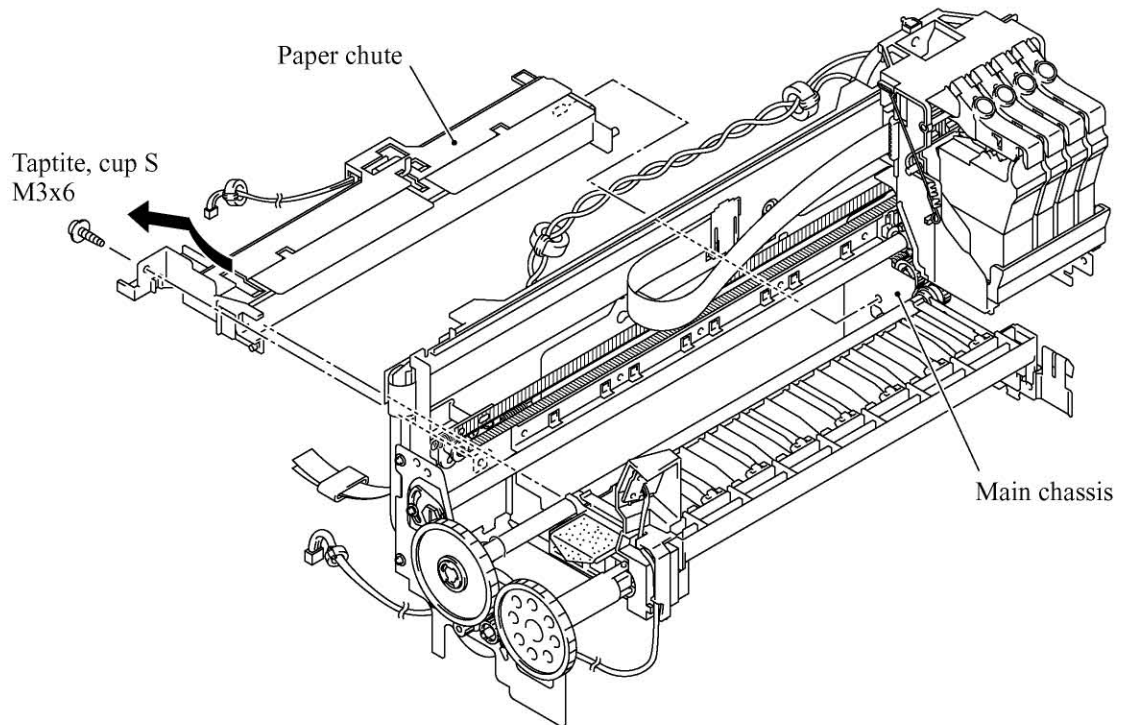

- (2) Unhook the registration sensor.
- (3) Unhook the actuator spring.
- (4) Push the lock arm and slide the sensor actuator in the direction of arrows ① and ②.

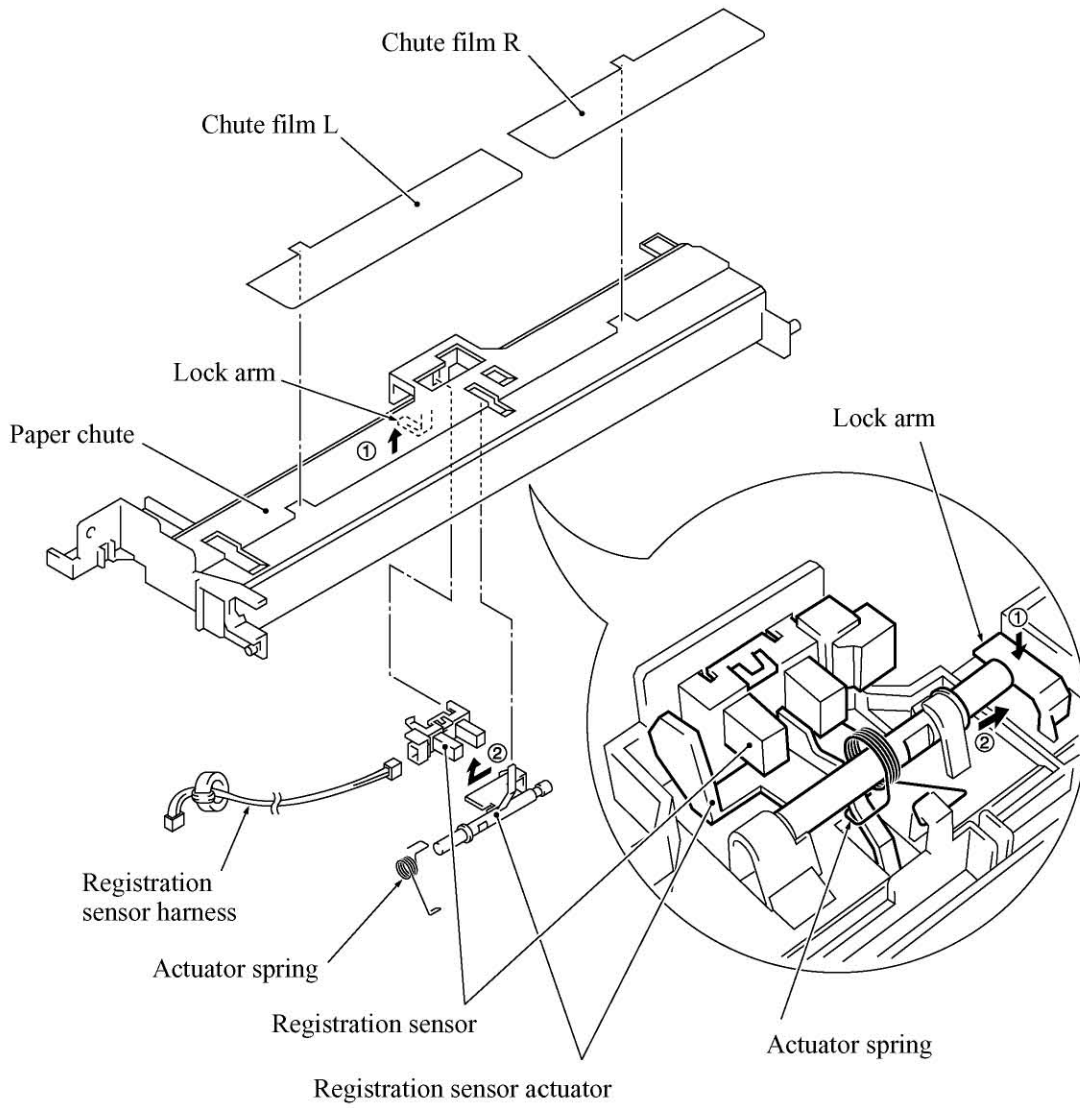

4.1.17 Paper Ejection Roller Gear, Ink Empty Sensor PCB, Platen, Star Wheel Support, and Paper Ejection Roller

- (1) Pull out the paper ejection roller gear from the left end of the paper ejection roller.
- (2) Remove the screw from the left side of the sensor support and take it off in the direction of the arrow.

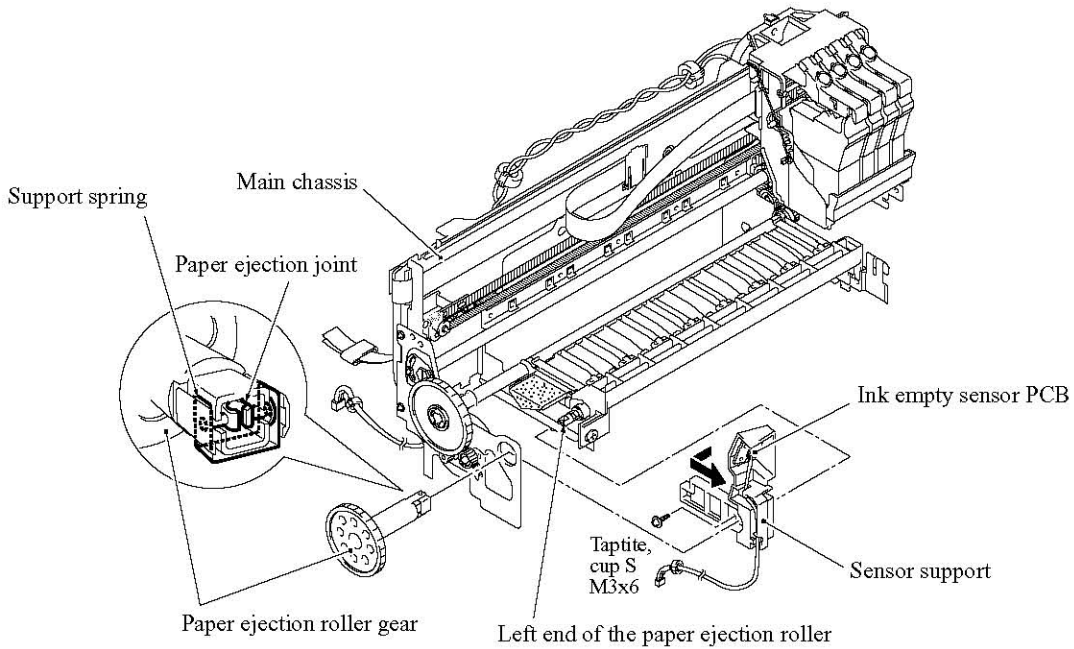

- (3) Remove the screw from the ink empty sensor PCB.

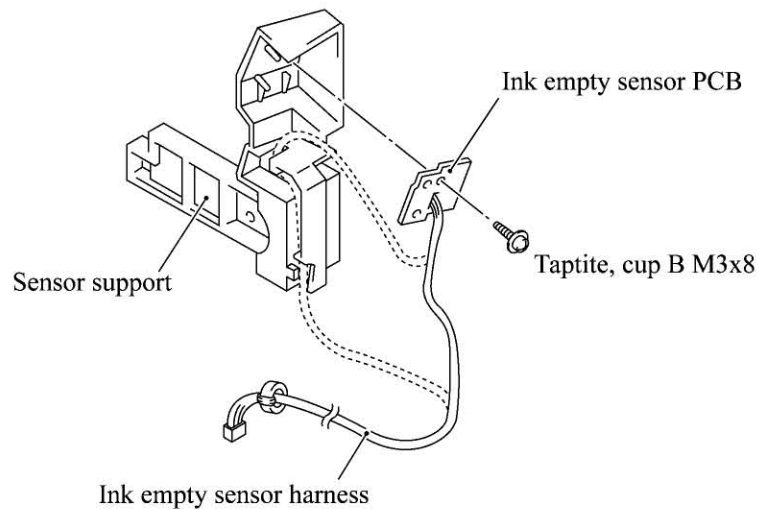

(4) Remove the screws from the platen and pull it out in the direction of the arrow.

NOTE: Take care not to touch the flushing sponge that is impregnated with ink.

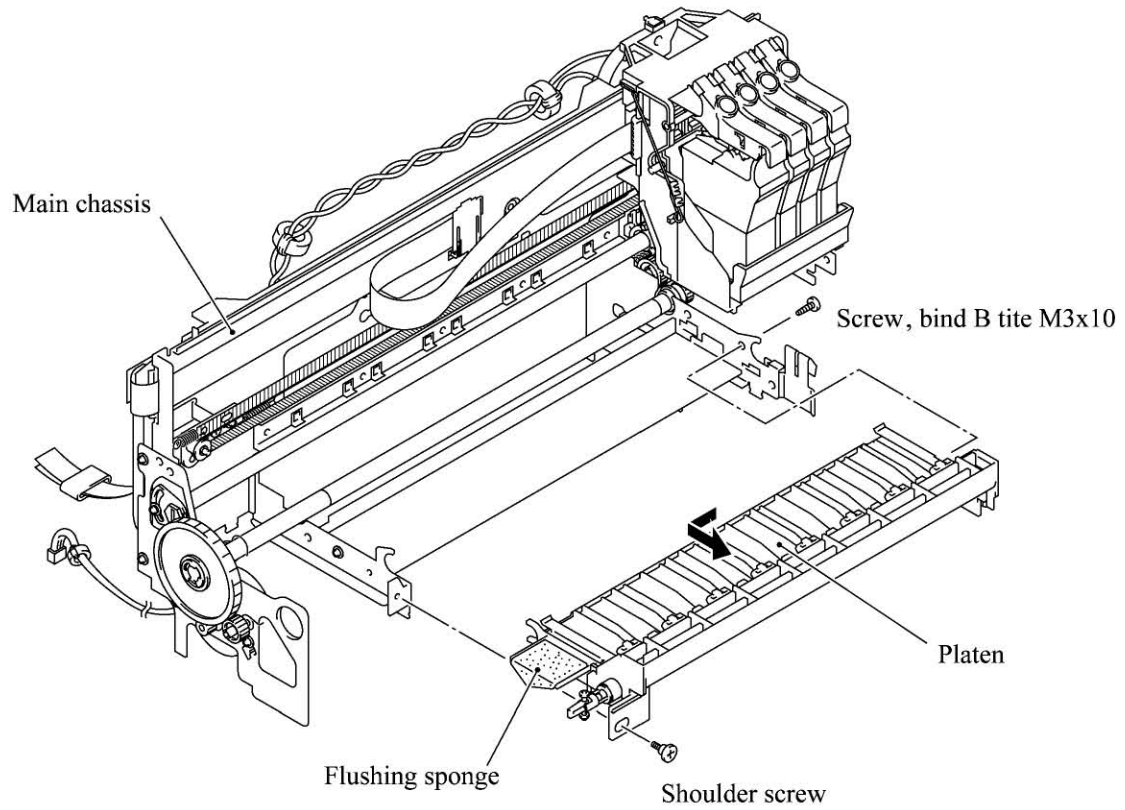

- (5) Unhook the four latches of the star wheel support and separate it from the platen.
- (6) Remove star wheels A and B from the star wheel support.
- (7) Pull out the paper ejection joint from the left end of the paper ejection roller.
- (8) Remove the pawled bushing by pulling its pawls outwards.
- (9) Remove the paper ejection roller and bushing (white).
- (10) Remove the screw from each of the right and left platen plates.

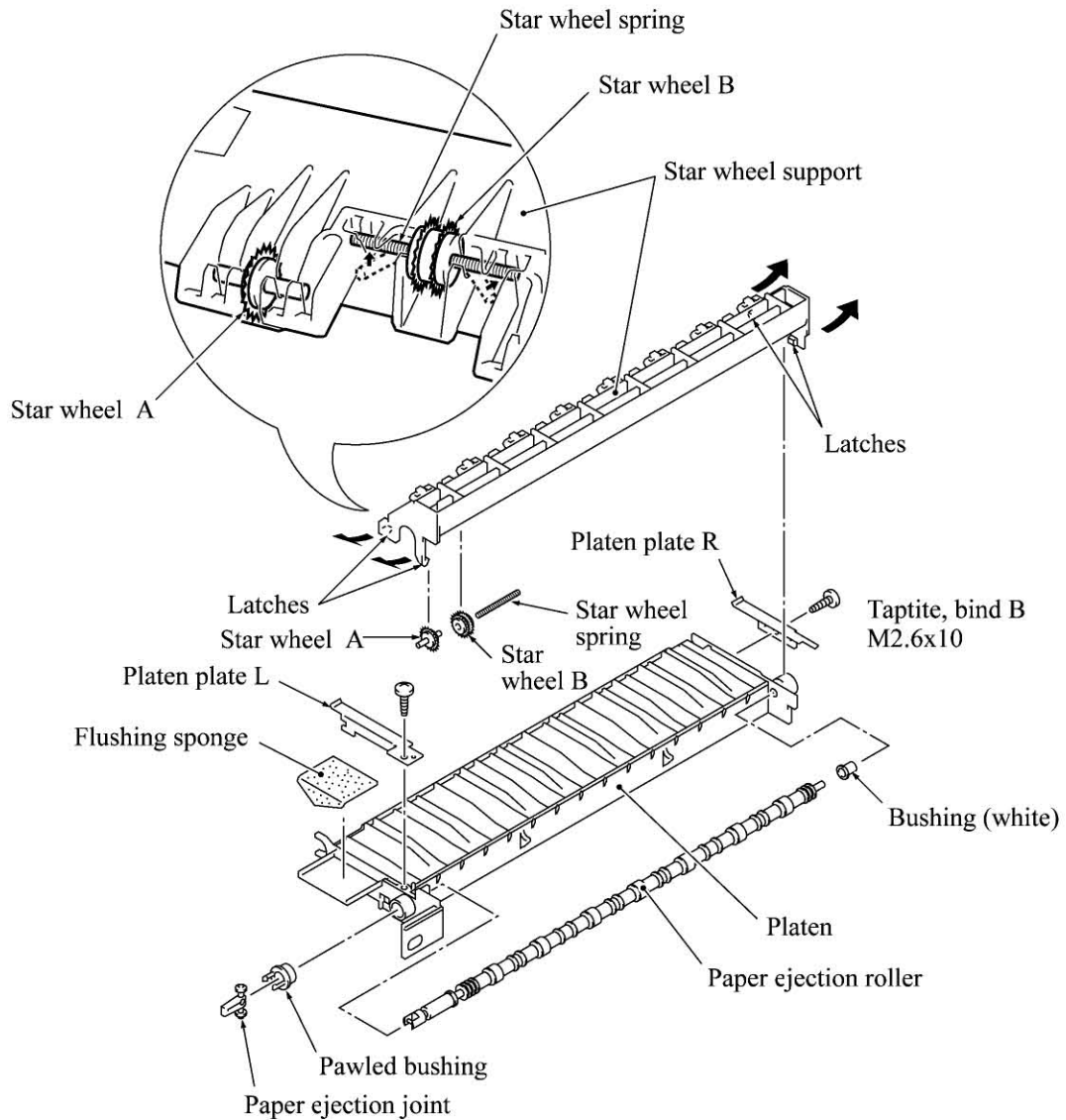

4.1.18 Paper Feed Motor and Paper Feed Roller

- (1) Remove the paper feed motor by removing the two screws.
- (2) Remove the crescent ring from the PF roller gear and pull out the gear.
- (3) Unhook the PF spring.
- (4) Turn the PF bushings as shown below and disengage them from the main chassis. Then remove the paper feed roller.

NOTE: When disengaging PF bushing R, slide the ASF/purge idle gear outwards.

NOTE: When removing the right end of the paper feed roller from the main chassis, move the carriage to the left; when removing the left end, move it to the right.

- (5) Remove the retaining ring from the PF idle gear, then pull out the gear and its spring.

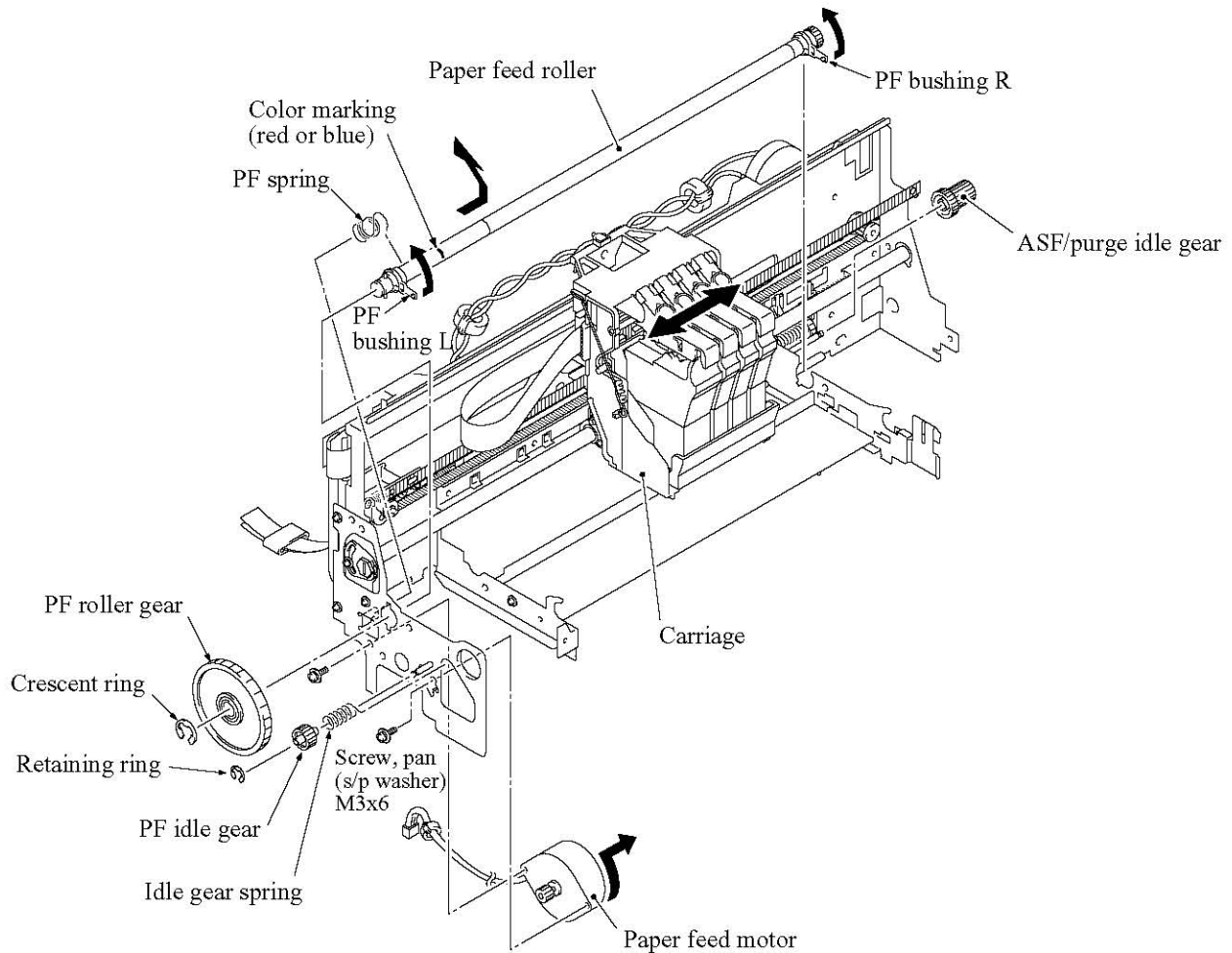

■ Reassembling Notes

- When replacing the paper feed roller, check the color marking (shown above) made on the current roller and use a new roller having the same color marking.
- When setting the PF spring into place, hook the looped end on the main chassis and the open end on the paper feed roller with its edge facing down.
- When installing the paper feed motor, face the connector towards the rear. When tightening the two screws, take care not to scratch the paper feed roller with a screwdriver.
- When fitting the PF roller gear over the left end of the paper feed roller, do not set it at an angle. Take care not to damage the gear teeth.

4.1.19 Encoder Strip and Carriage Motor

- (1) At the left end of the encoder strip, unhook the spring from the main chassis.

NOTE: Take care not to scratch or damage the encoder strip.

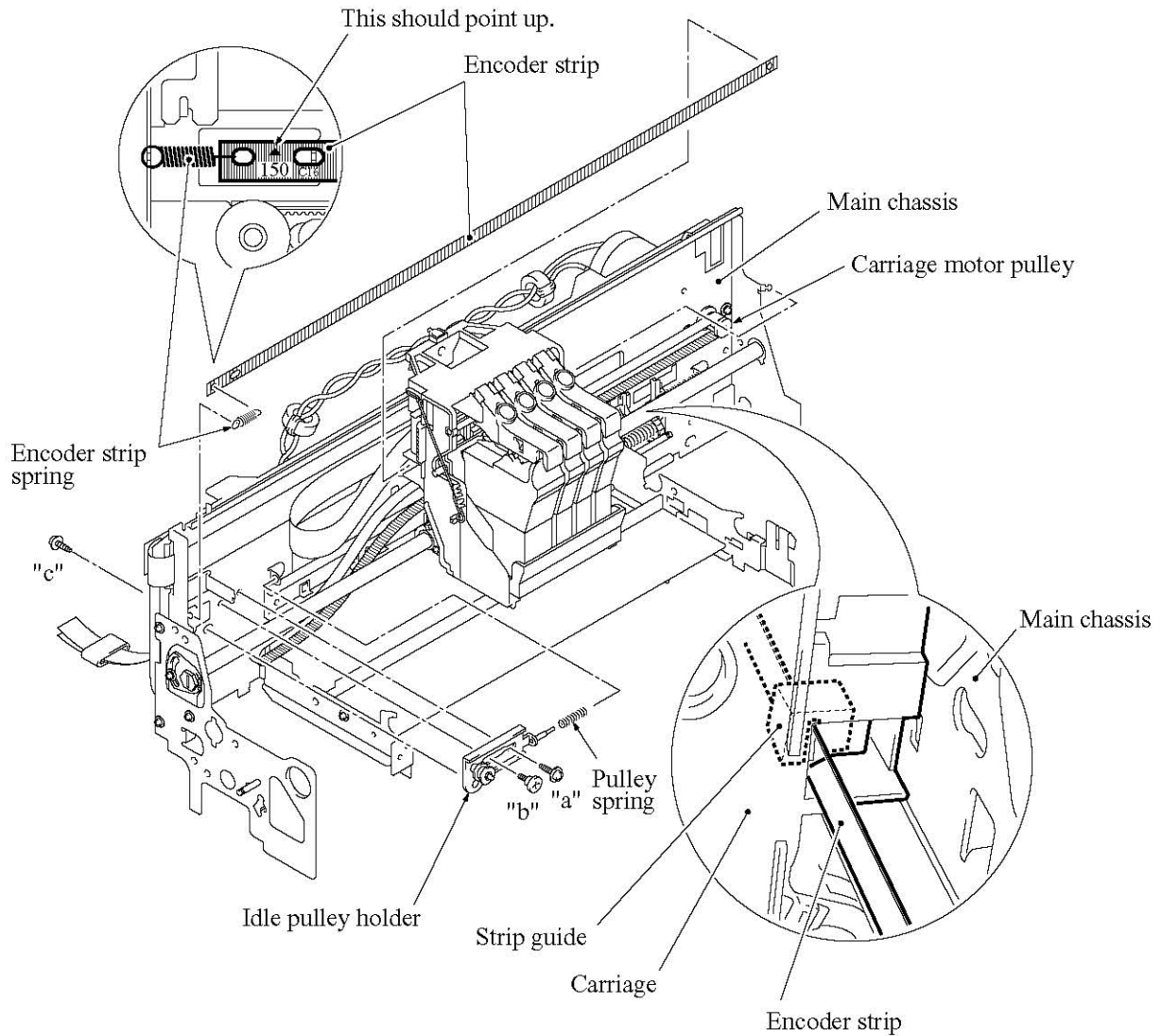

"a": Taptite, cup S M3x8

"b": Shoulder screw

"c": Screw, cup S tite M3x6

- (2) Move the carriage to the center of its travel.
- (3) Loosen two screws "a" and "c" on the idle pulley holder. (See the above illustration.)
- (4) While pushing the idle pulley holder to the right, remove the timing belt from the carriage motor pulley and idle pulley.

(5) Remove the carriage motor by removing the two screws.

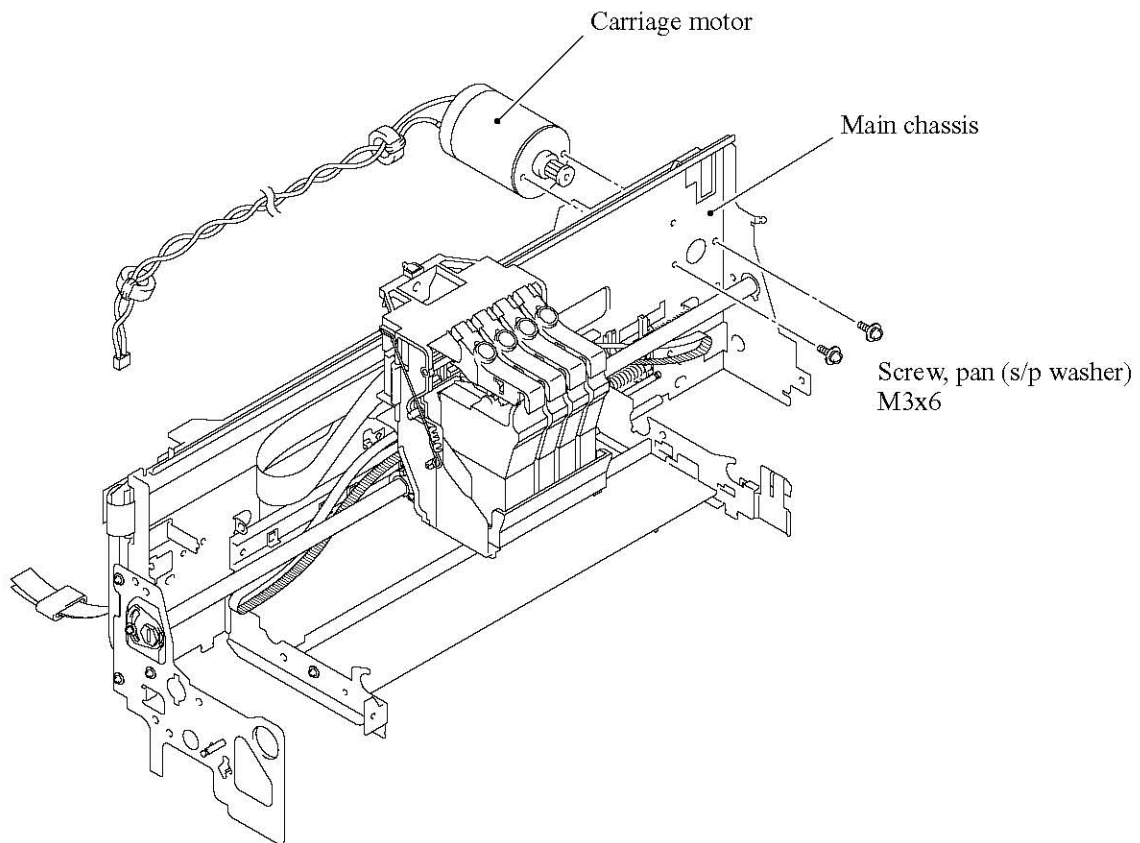

■ Reassembling Notes

- Pass the encoder strip through the strip guide provided on the back of the carriage so that the encoder strip will route as illustrated on the previous page and the ▲-marked end comes to the left. Then hook the ▲-marked end on the spring hooked on the main chassis so that the ▲ mark points up.

4.1.20 Carriage Rail, Carriage ASSY, and Purge-Related Parts

(1) If the ink cartridges and print head have not been removed, remove them as follows:

Push the colored ink cartridge covers and remove all ink cartridges (arrow ①).

Pull the head clamp springs in the direction of arrow ② to release the print head.

Lift the print head up and out of the carriage (arrow ③).

NOTE: Do not touch the printing ends (nozzles) of the print head unit or the ink orifices of the ink cartridges; doing so will not only stain your hands with ink but result in an ink jet-out failure. Once you touch them, clean them with a dedicated cleaning stick and liquid.

NOTE: Be sure to put a head nozzle seal and filter seal on the print head unit (shown on page 4-6). Leaving the print head unit without those seals will dry up its printing ends and filters, resulting in a damaged head.

NOTE: Do not touch the dimple contact section of the print head unit.

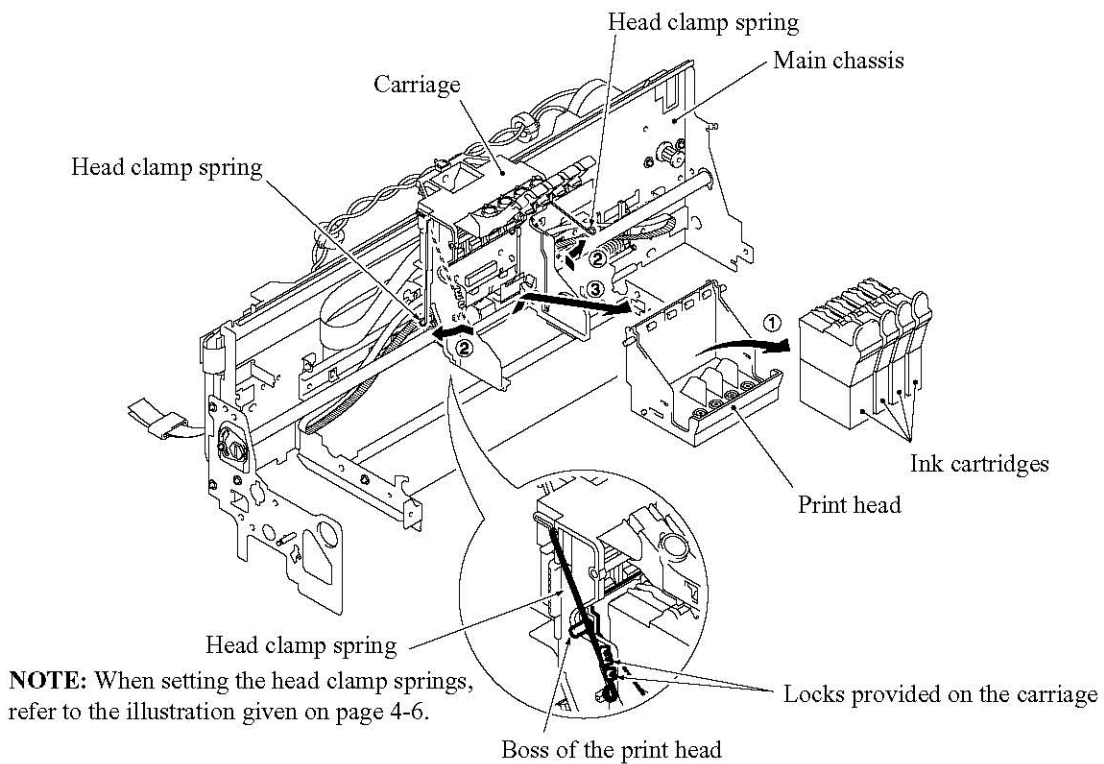

NOTE: When setting the head clamp springs, refer to the illustration given on page 4-6.

(2) Remove the head clamp springs as shown below.

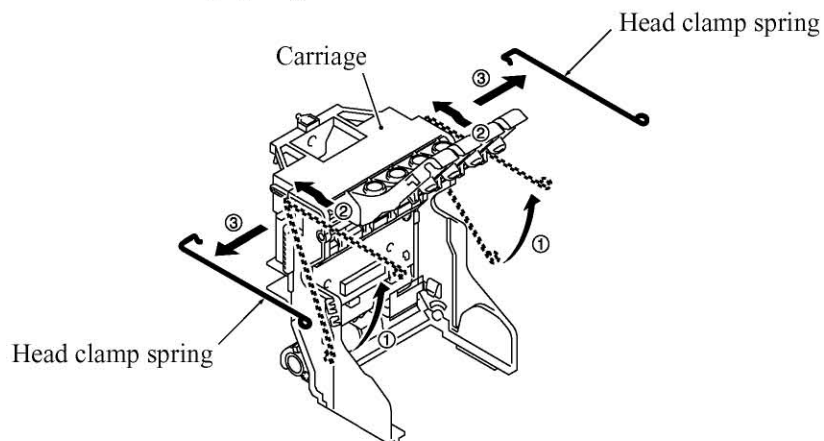

- (3) Remove the screw from the eccentric bushing R, then turn it to align its boss with the cutout provided in the main chassis and pull it out. The wavy washer also comes off.

NOTE: Take care not to lose the wavy washer.

- (4) Pull out the carriage rail to the right.

NOTE: The oil-impregnated carriage felt will drop from the carriage.

- (5) At the left side of the main chassis, remove the screw from the eccentric bushing L, if necessary.

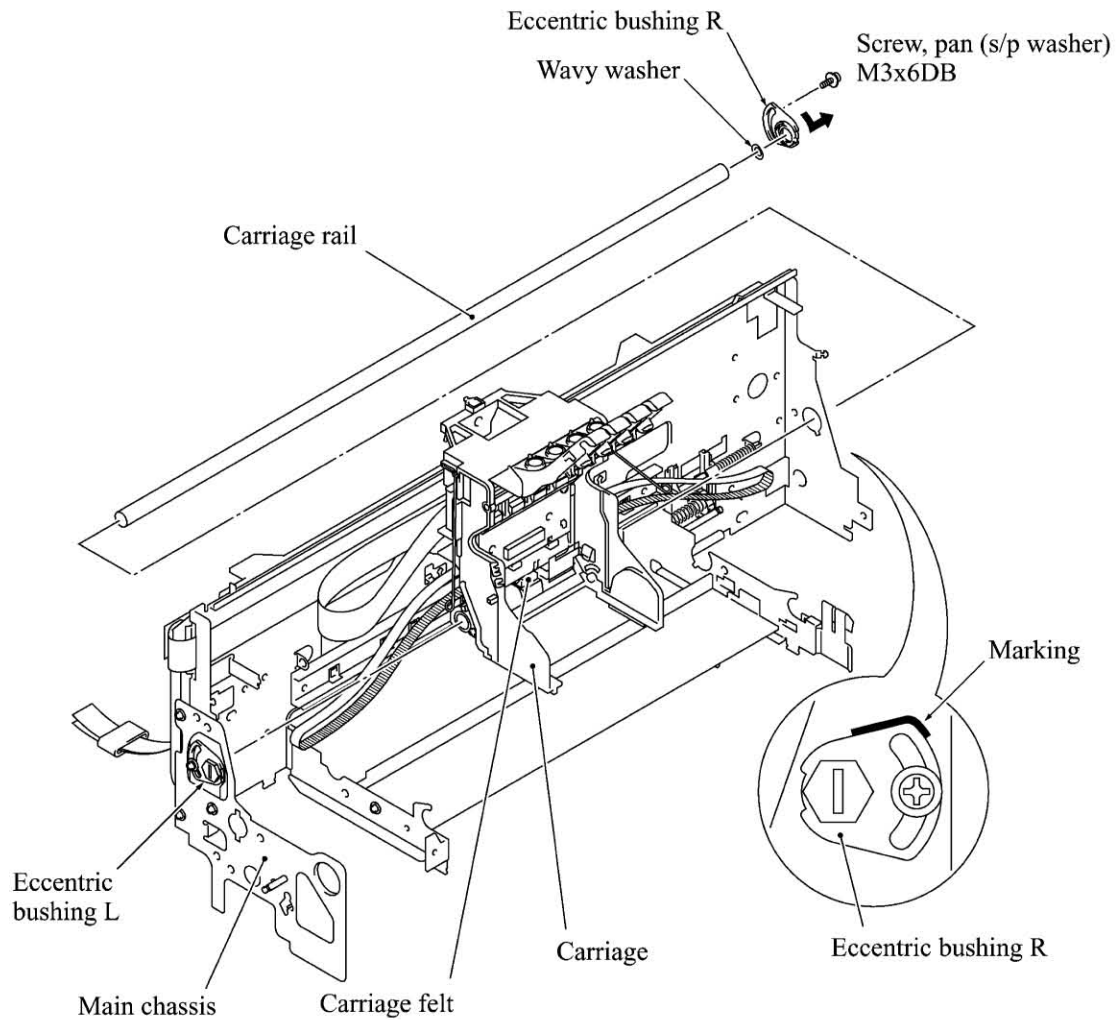

- (6) From the rear side of the main chassis, remove the cable clamp stopper that is attached with double-sided adhesive tape. From the front side, unlatch the flat cable clamp to release the head flat cables.
- (7) Remove the FFC clamp film from the left end of the main chassis.
- (8) Remove tapes from the flat cable guide. The carriage is now completely separated from the main chassis.

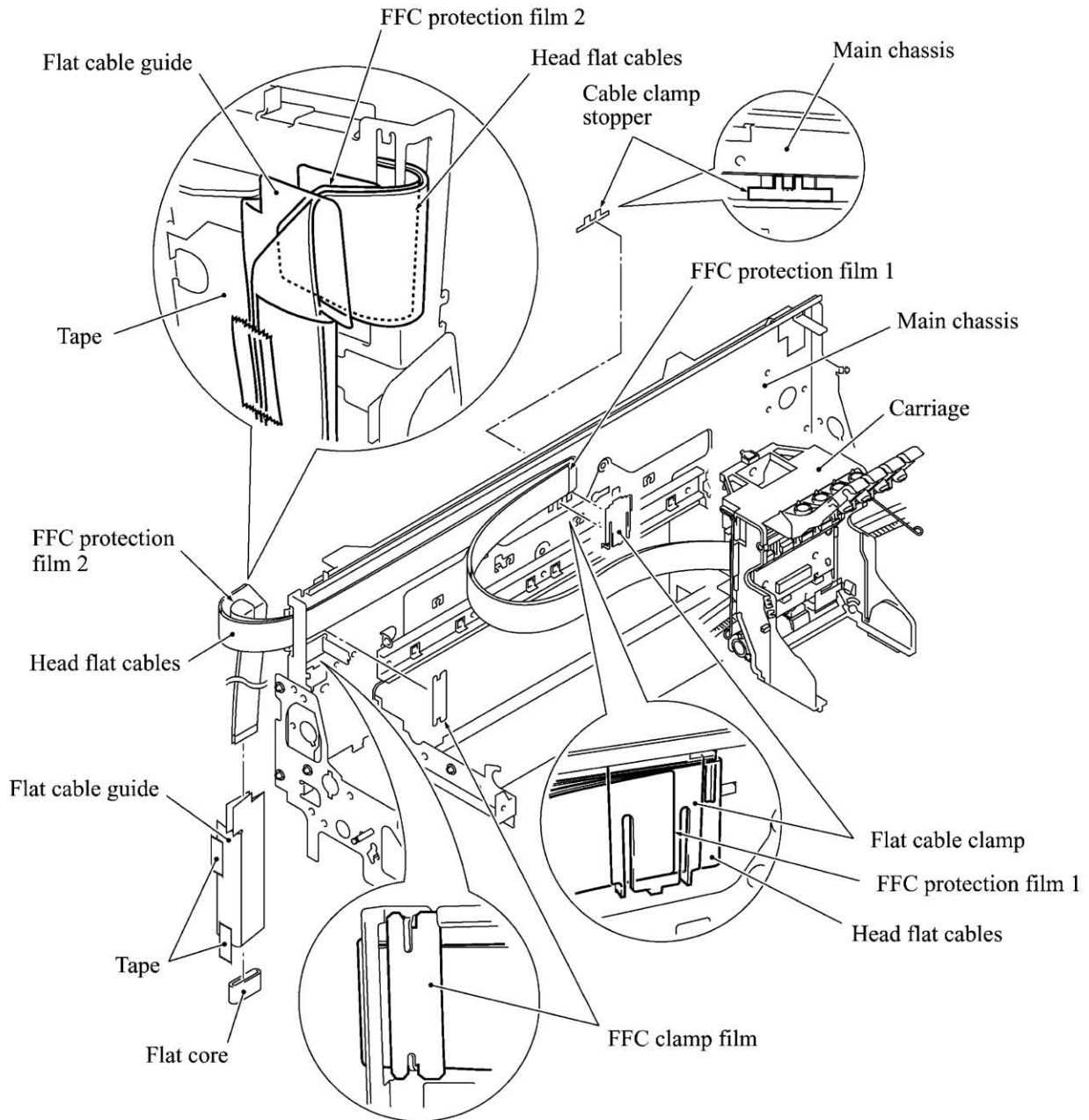

- (9) Remove the timing belt from the back of the carriage.

- (10) Push up the carriage PCB to unhook its lower edge from the PCB holders and remove the PCB together with the sensor actuator support.

Unlatch the sensor actuator support from the carriage PCB.

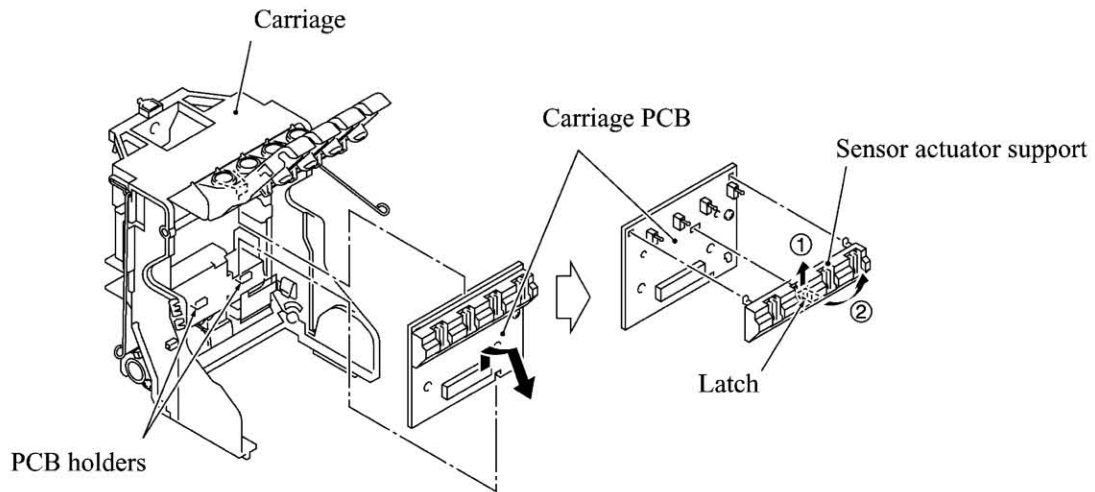

- (11) Press the right end of the purge shaft inwards and pull it out of the purge lever. The purge lever spring also comes off.
- (12) Remove the ASF-purge switching gear 23 and its spring.

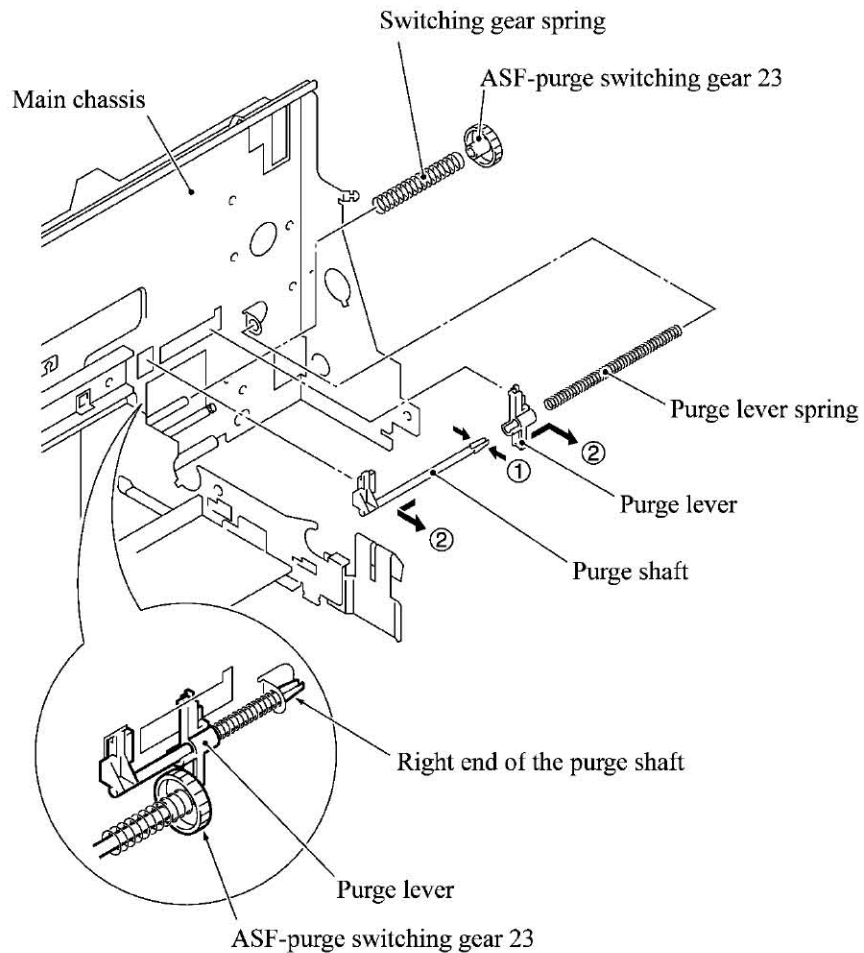

■ Reassembling Notes

- To install the carriage rail, temporarily set the eccentric bushing L to the left side of the main chassis with the screw, align the bushing L with marking made on the main chassis, and then tighten the screw firmly.

Pass the carriage rail through the opening in the right side of the main chassis and through the carriage, then fit it into the eccentric bushing L.

Next, fit the eccentric bushing R over the right end of the carriage rail, temporarily set the bushing R to the right side of the main chassis with the screw, align the bushing R with marking made on the main chassis, and then tighten the screw firmly.

This alignment with markings is required for keeping the head-platen gap properly.

- When setting the head clamp springs, refer to the illustration given on page 4-6.
- If you replace the carriage ASSY, be sure to correct the positioning error of the print head unit. (Refer to Section 4.3 "ADJUSTMENT.")

4.1.21 Flushing Box

- (1) From the bottom, insert the tip of a flat screwdriver to unhook the latch and then slide the flushing box to the front and upwards.

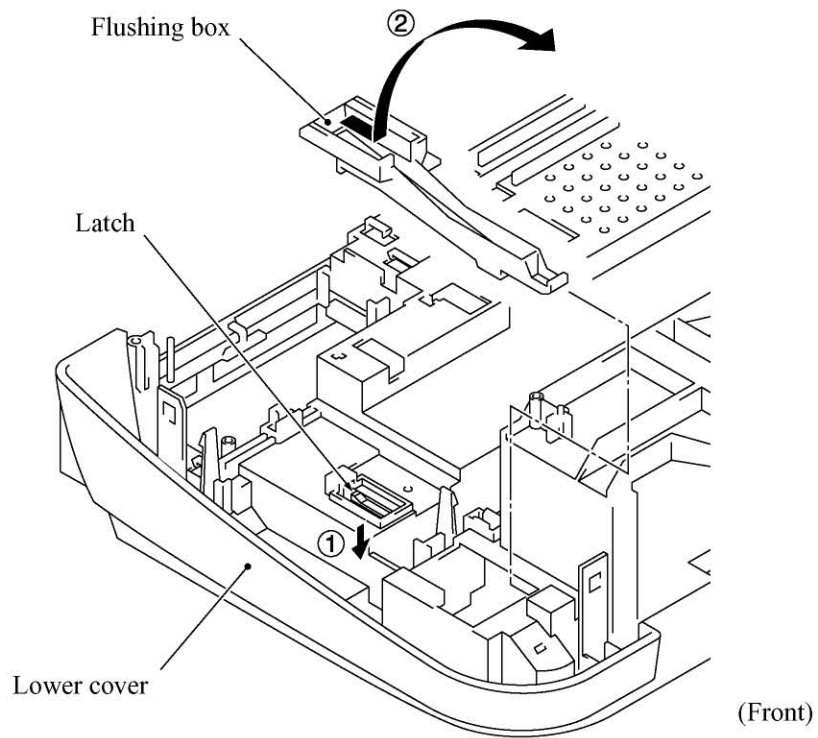

4.1.22 Harness Routing

Harness routing A: Main PCB-related harnesses

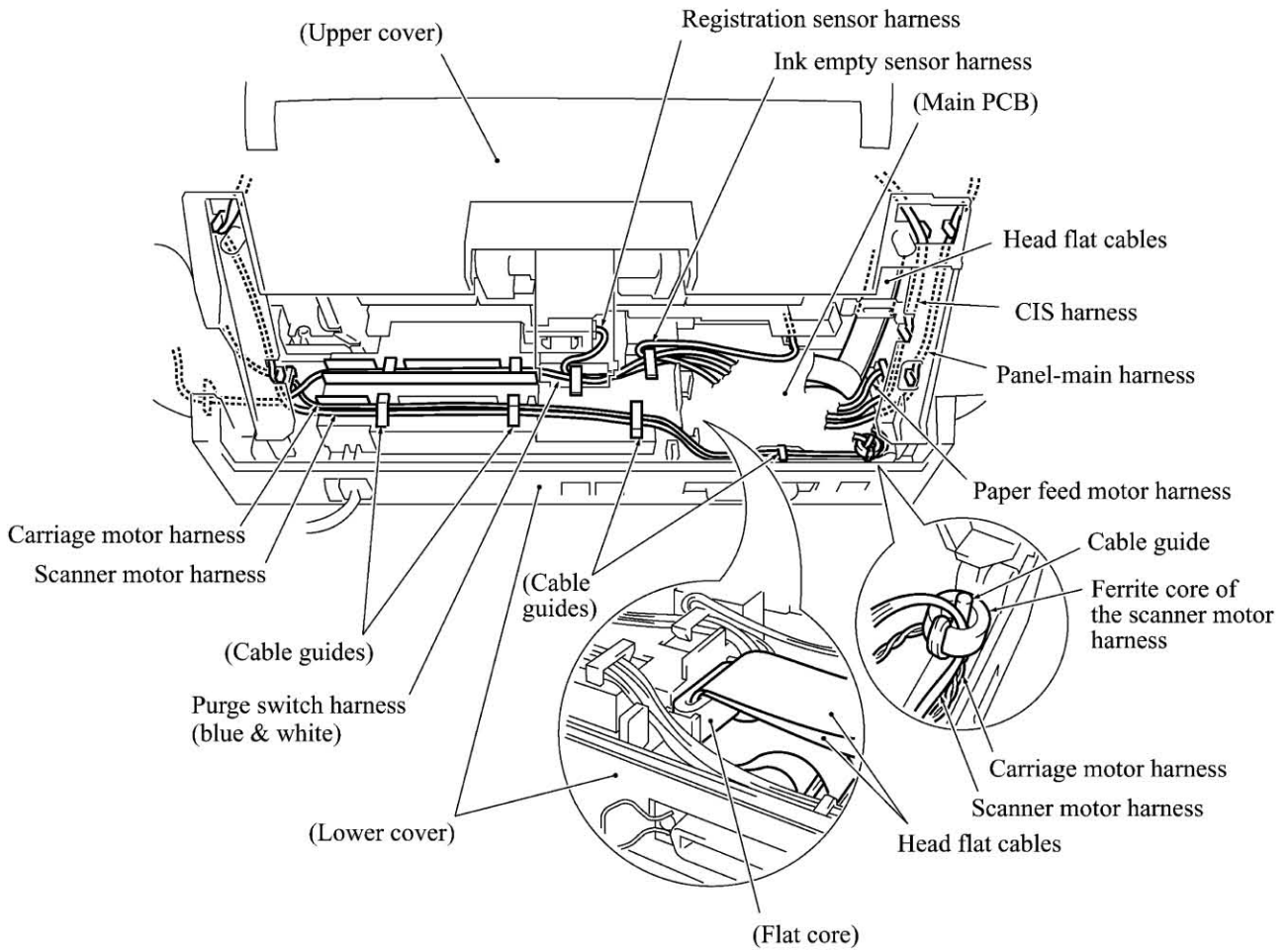

Harness routing B: Scanner motor harness on the inside of the upper cover

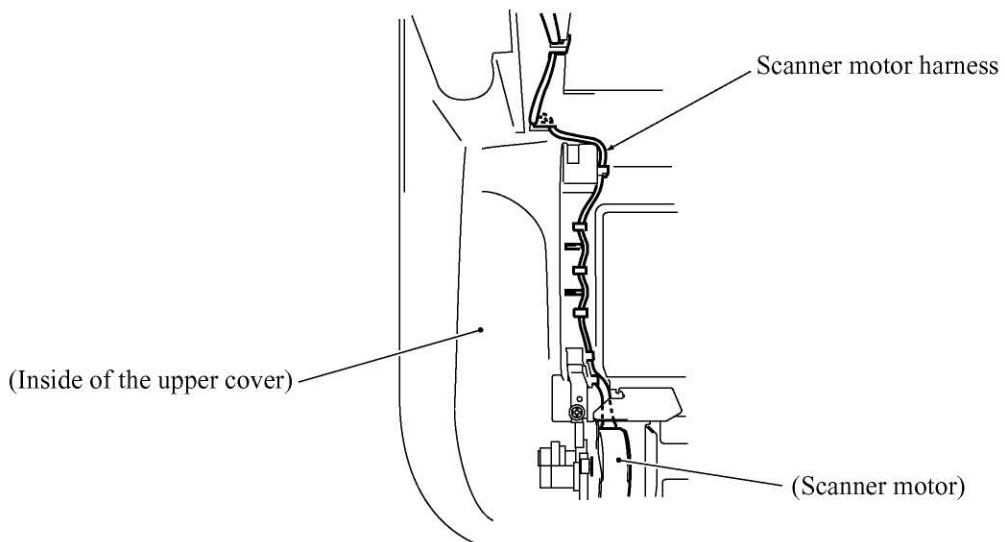

Harness routing C: Panel-main harness and CIS harness on the inside of the upper cover

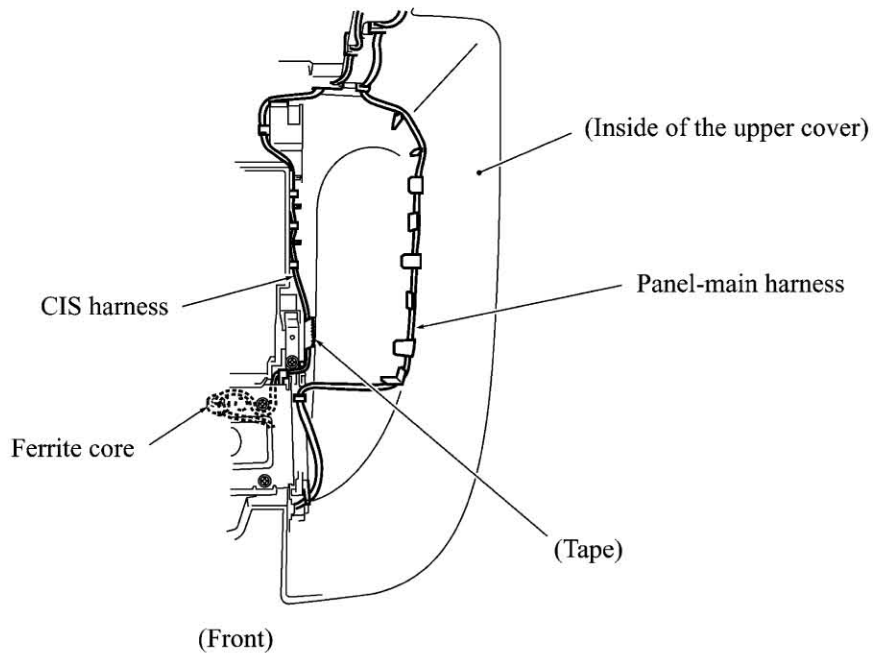

Harness routing D: Purge cam HP switch harness and pump switching cam HP switch harness on the lower cover

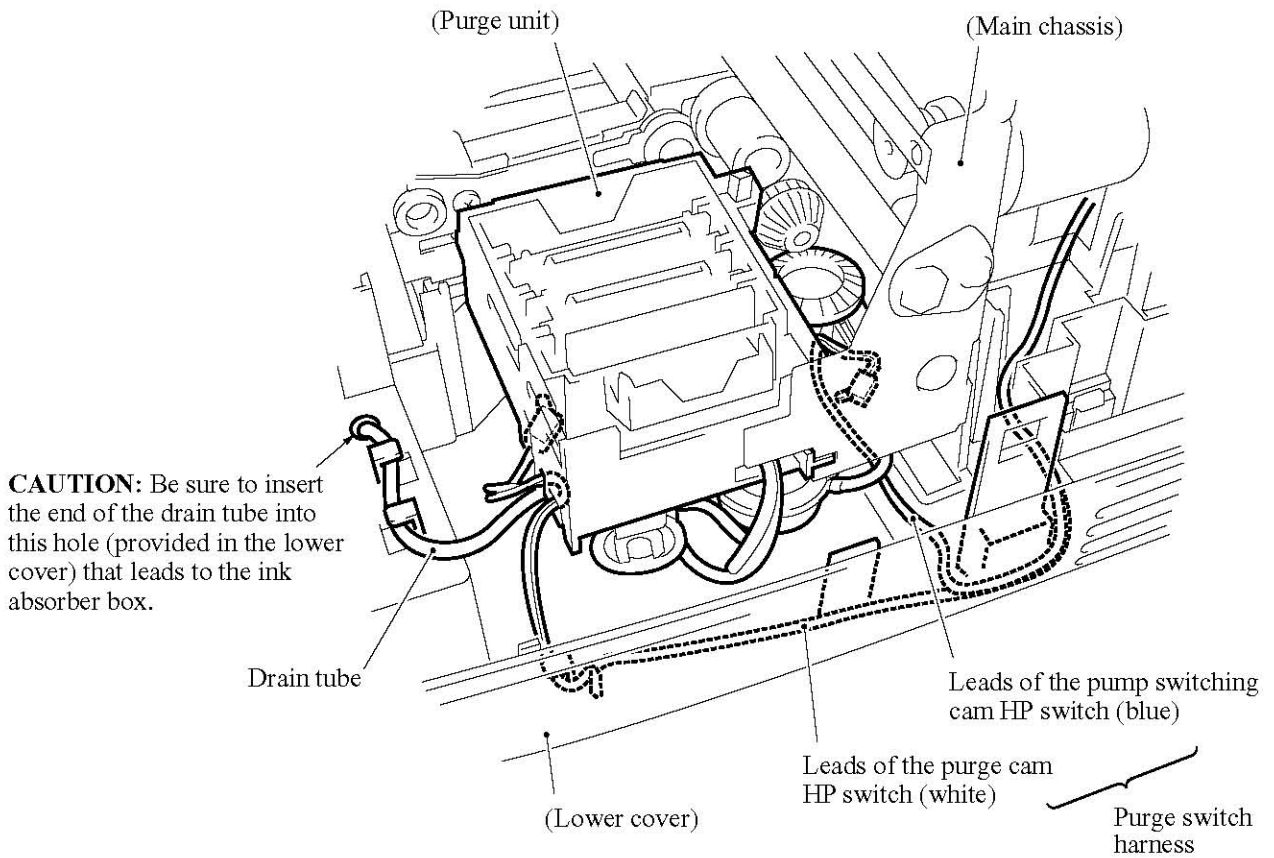

4.2 LUBRICATION

Apply the specified lubricants to the lubrication points as shown below.

Lubricant type (Manufacturer)	Lubricant amount				
	Thin coat of grease with a brush	1/4 sesame-sized pinch of grease (0.5 mm dia. ball)	Sesame-sized pinch of grease (2 mm dia. ball)	Rice-sized pinch of grease (3 mm dia. ball)	Bean-sized pinch of grease (4 mm dia. ball)
Molykote EM-30LG or EM-30L (Dow Corning)	_____	(EM0.1)	(EM0.5)	(EM1)	(EM2)
Molykote EM-50LS (Dow Corning)	_____	_____	_____	(EML1)	(EML2)
Conductive grease FLOIL 951P-32 (Kanto Kasei Ltd.)	(P0.02)	_____	_____	_____	_____

[1] Separation roller and its gear

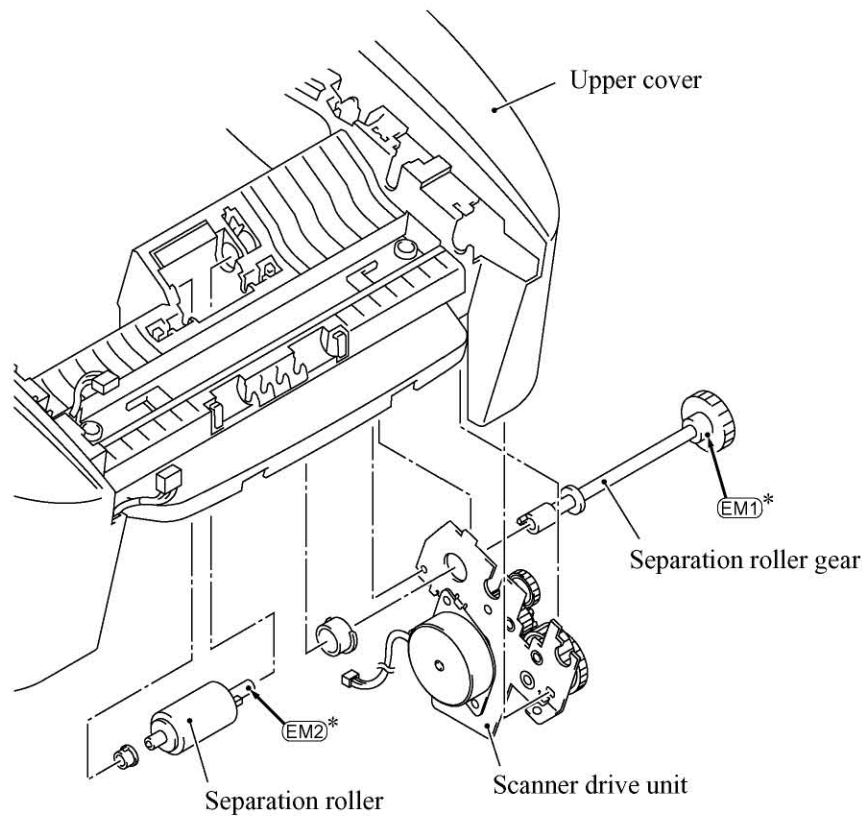

*EM-30L (Not EM-30LG)

[2] ASF roller unit

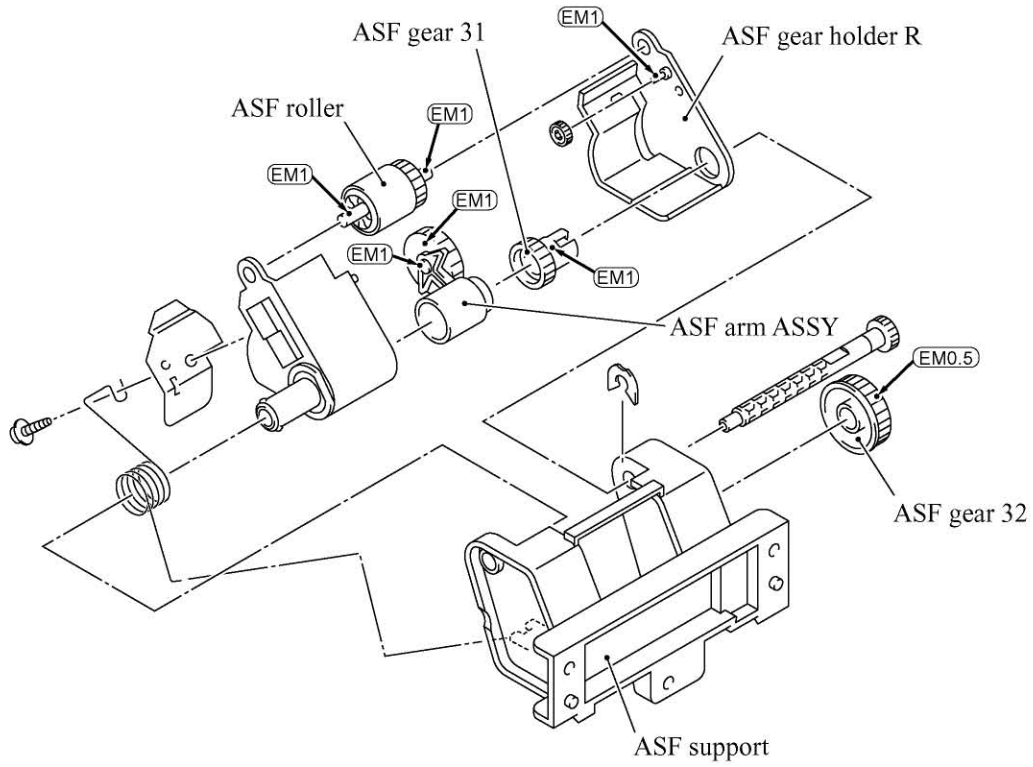

[3] Paper ejection roller and platen

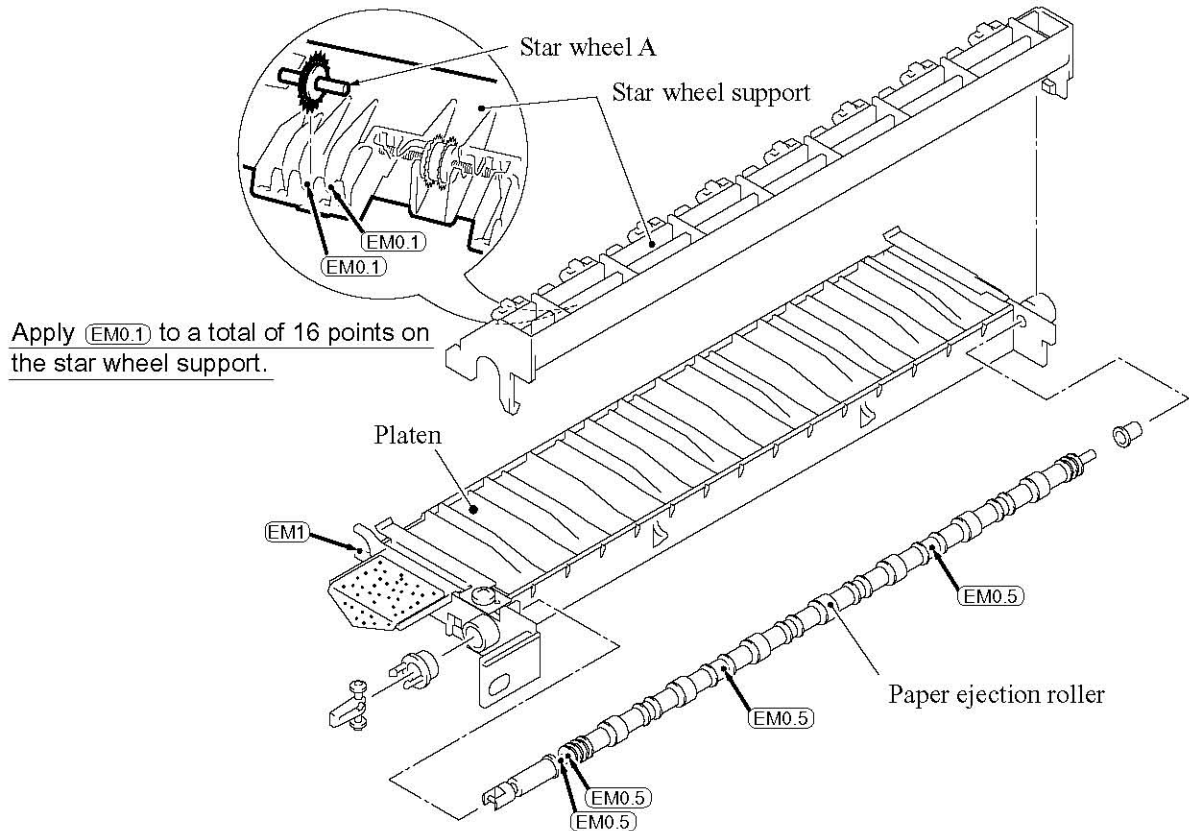

[4] Paper ejection roller gear and PF roller gear

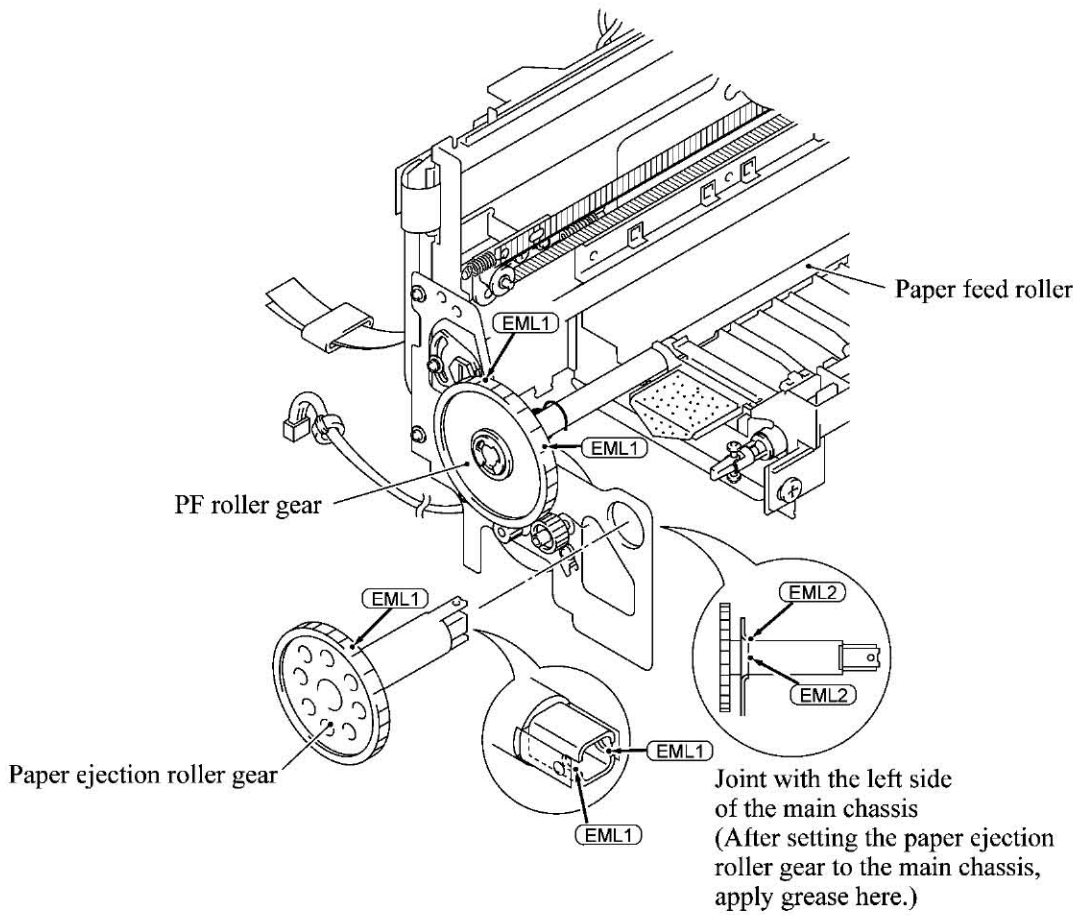

[5] Paper feed roller and PF spring

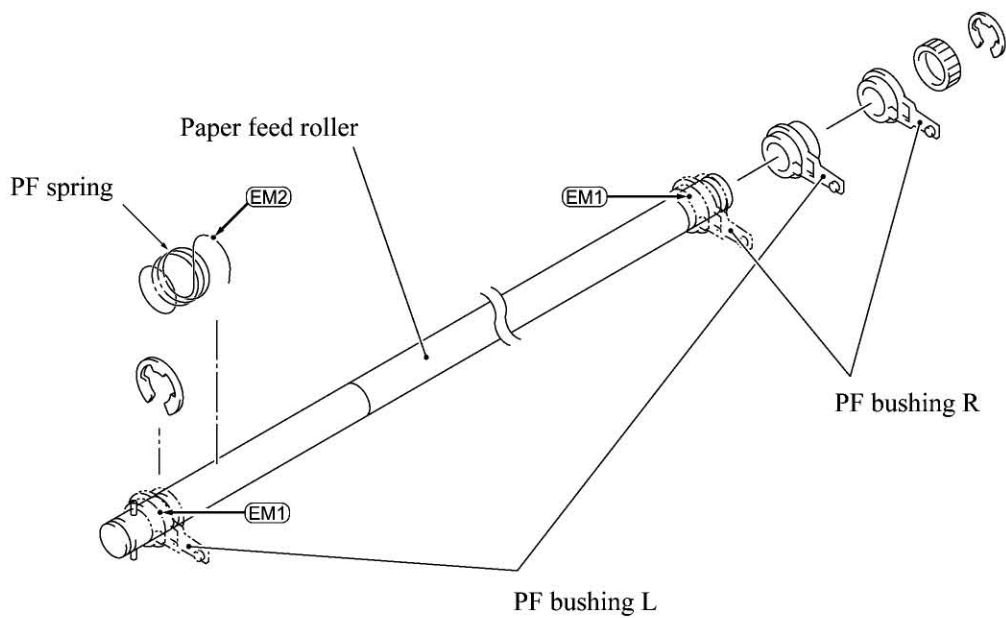

[6] Carriage rail

Apply a thin coat of grease to the right and left edges of the carriage rail with a brush.

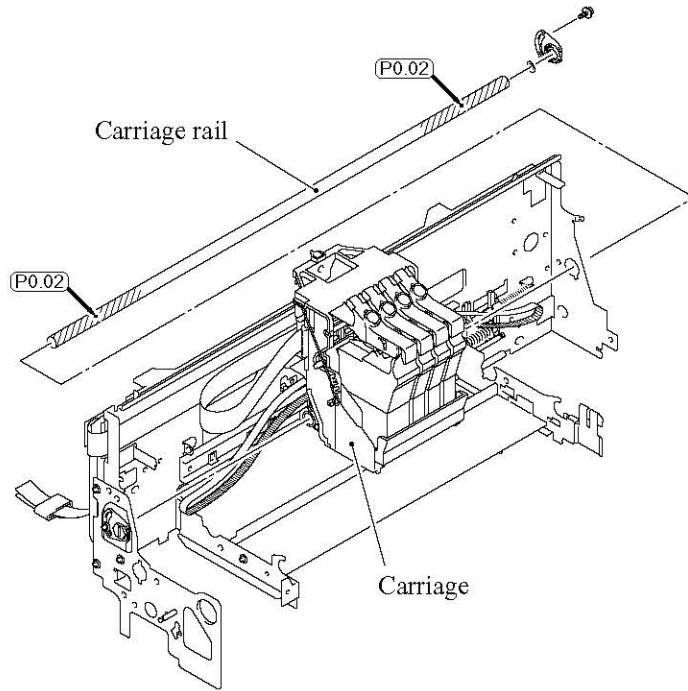

[7] Main chassis (slideway of the carriage guide)

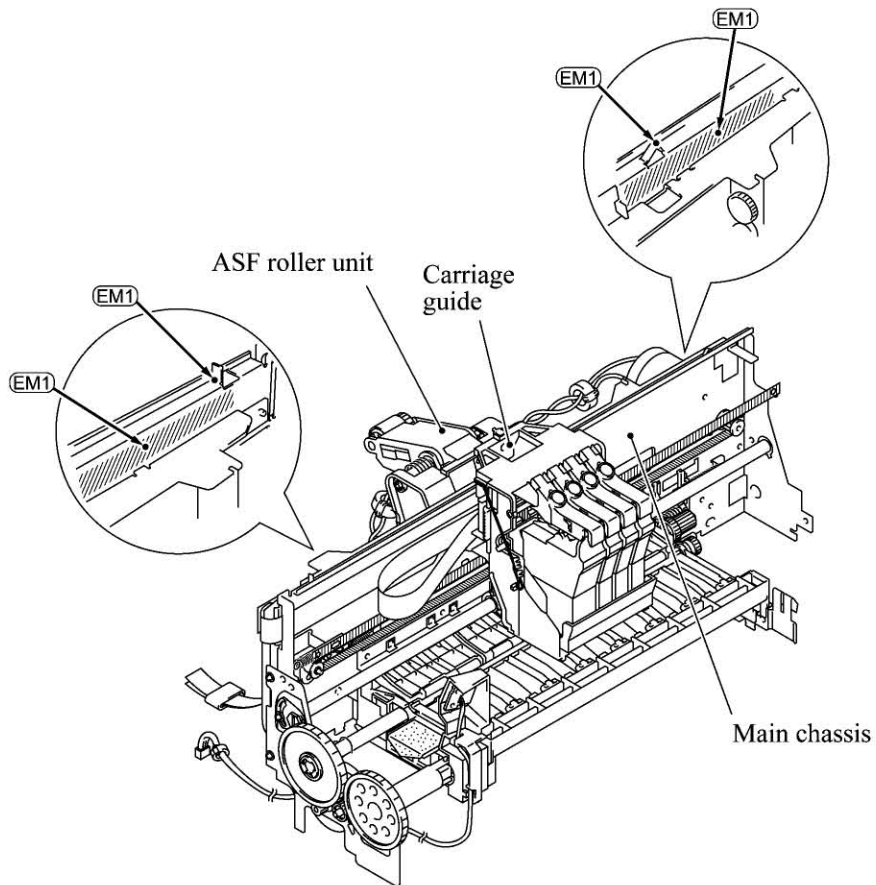

[8] Purge shaft

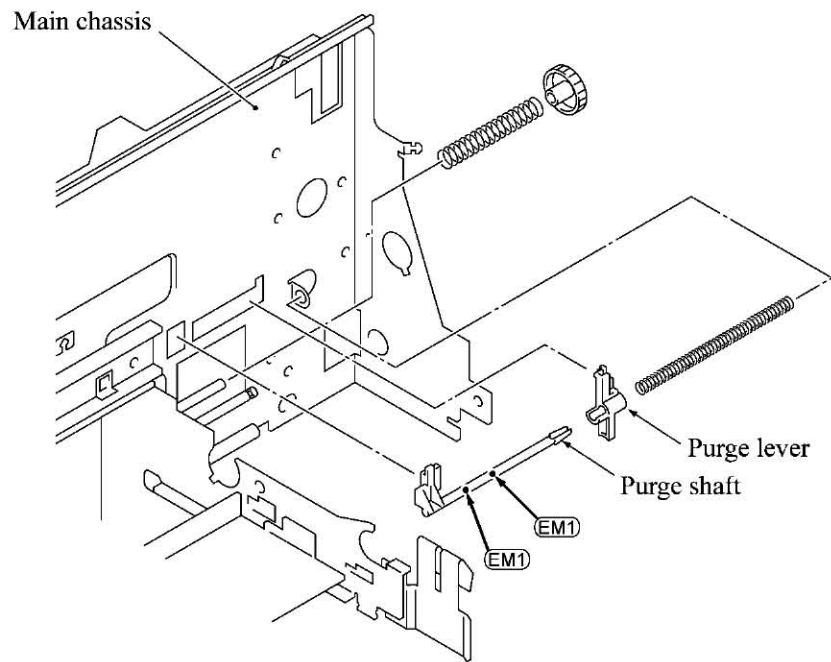

4.3 ADJUSTMENT

Correcting the positioning error of the print head

Once the print head or carriage is removed, you need to correct the positioning error of the print head according to the procedure given below. The head nozzle columns should be perpendicular to the carriage travel path.

NOTE: This adjustment procedure requires a PC and the specified test chart data.

- (1) Make sure that your PC is turned off.
- (2) Make sure that the machine's power cord is unplugged from a wall socket or other power source.
- (3) Connect the machine to your PC as follows:
Connect the parallel interface cable to the parallel port on the back of the machine and secure it with the lock wires.
Connect the other end of the interface cable to the printer port of your PC and secure it with the two screws.
- (4) Plug the machine's power cord into a wall socket or other power source. Then open the control panel and top cover.
- (5) Turn on your PC.
- (6) Make sure that:
 - the print head is secured to the carriage by the head clamp springs,
 - the ink cartridges are set into place, and
 - paper is loaded in the ASF.
- (7) Turn the head adjuster lever located on the right side of the carriage to position 1. (See the illustration given below.)
- (8) Press the bottom right front corner of the print head to the rear to fit the eccentric section of the print head over the inside boss of the head adjuster lever.

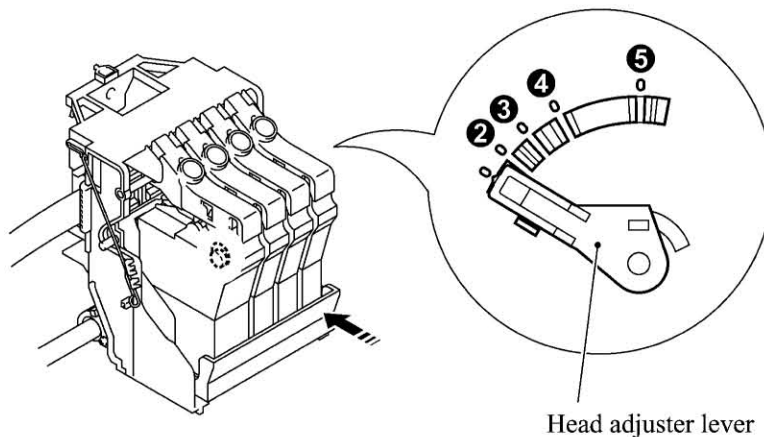

- (9) Close the top cover and control panel.

- (10) From your PC, send the specified test chart to the machine to print it out.
- (11) Check the printed test patterns 1 through 5 (see the test pattern sample given on the next page) and choose one that has the least uneven print (Pattern 1 in this sample). Make a note of the pattern number.
- (12) Press the **Ink** key on the machine's control panel to place it in the ink replacement mode.
The carriage automatically moves to the ink replacement position.
- (13) Open the control panel and top cover.
- (14) Turn the head adjuster lever to the position indicated by the pattern number you recorded in step (11).

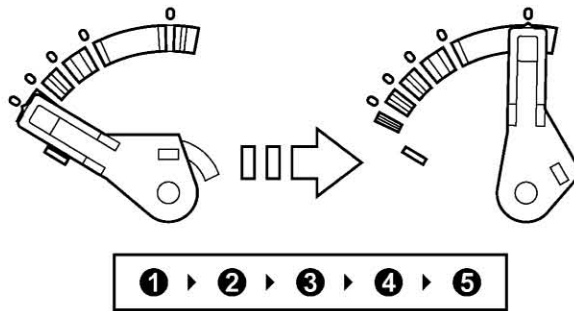

NOTE: Always turn the head adjuster lever in an ascending order. If you want to set the head adjuster lever to position 3, for example, turn it from 1 to 3. Once you have turned it to position 4, you need to turn it back to position 1 and then turn it to 3.

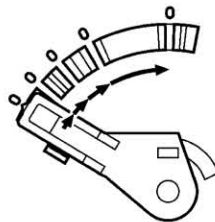

- (15) Close the top cover and control panel.

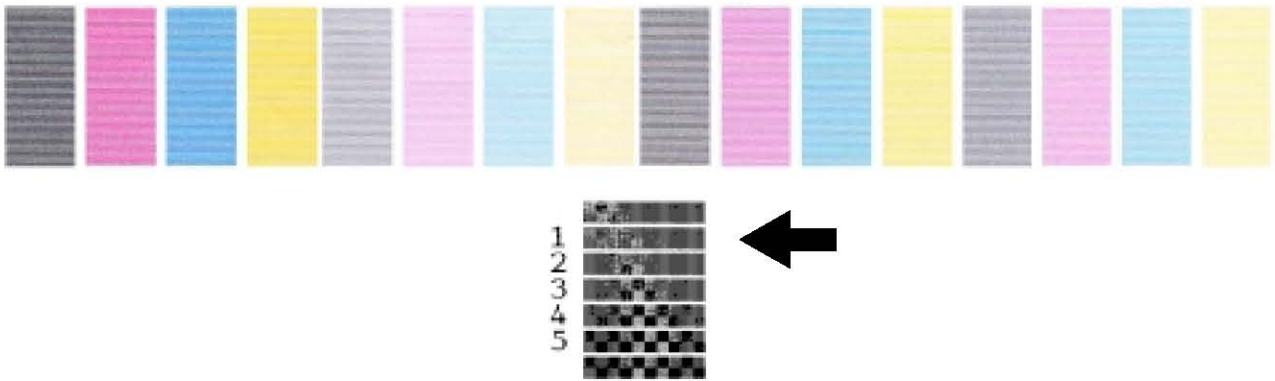

Turn the head adjust lever to the position indicated by the above pattern number

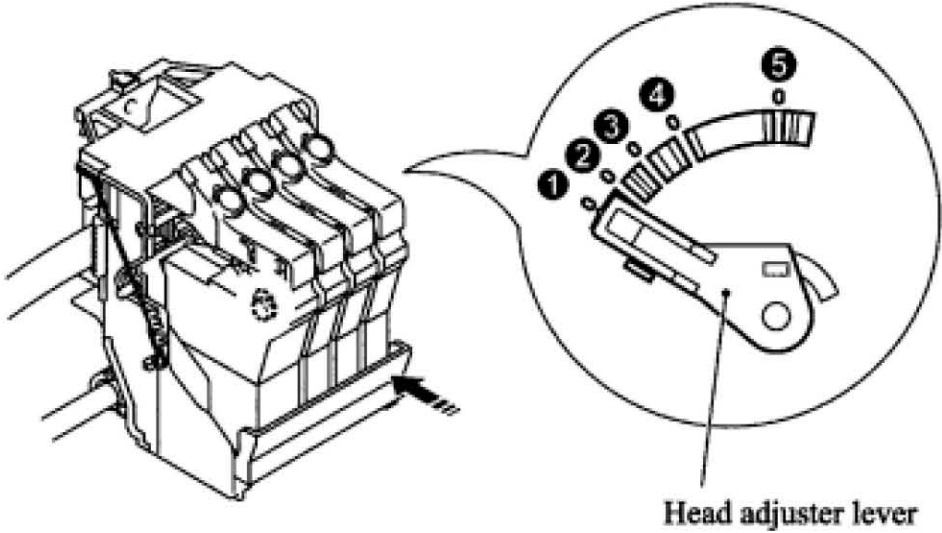

Head Positioning Test Pattern

CHAPTER 5 MAINTENANCE MODE

CONTENTS

5.1	ENTRY INTO THE MAINTENANCE MODE	5-1
5.2	LIST OF MAINTENANCE-MODE FUNCTIONS	5-2
5.3	DETAILED DESCRIPTION OF MAINTENANCE-MODE FUNCTIONS	5-4
5.3.1	EEPROM Parameter Initialization	5-4
5.3.2	Printout of Scanning Compensation Data	5-5
5.3.3	ADF Performance Test	5-7
5.3.4	Test Pattern 1	5-8
5.3.5	Firmware Switch Setting and Printout	5-9
5.3.6	Operational Check of LCD	5-12
5.3.7	Operational Check of Control Panel PCB	5-13
5.3.8	Receiver Volume Adjustment (Applicable to the FAX1800C)	5-15
5.3.9	Sensor Operational Check	5-16
5.3.10	Fine Adjustment of Scanning Start/End Position	5-17
5.3.11	CIS Scanner Area Setting	5-18
5.3.12	Setting the Sensing Reference Level of the Ink Empty Sensor	5-19
5.3.13	Alignment of Vertical Print Lines	5-20
5.3.14	Updating of Head Property Information	5-22
5.3.15	Initial Adjustment of PWM Value (Aging of the Carriage)	5-23
5.3.16	EEPROM Customizing	5-24
5.3.17	Display of the Equipment's Log Information	5-25
5.3.18	Equipment Error Code Indication	5-26
5.3.19	Output of Transmission Log to the Telephone Line	5-26
5.3.20	Cancellation of the Pin TX Lock Mode (Not applicable to American models)	5-27

5.1 ENTRY INTO THE MAINTENANCE MODE

To make the facsimile equipment enter the maintenance mode, press the **Menu**, *****, **2**, **8**, **6**, and **4** keys in this order.

←Within 2 seconds→

The equipment beeps for approx. one second and displays " ■■ MAINTENANCE ■■■ " on the LCD, indicating that it is placed in the initial stage of the maintenance mode, a mode in which the equipment is ready to accept entry from the keys.

To select one of the maintenance-mode functions listed in Section 5.2, enter the corresponding 2-digit function code with the numerical keys on the control panel. (The details of each maintenance-mode function are described in Section 5.3.)

- NOTES:**
- Pressing the **9** key twice in the initial stage of the maintenance mode makes the equipment exit from the maintenance mode, restoring it to the standby state.
 - Pressing the **Stop** key after entering only one digit restores the equipment to the initial stage of the maintenance mode.
 - If an invalid function code is entered, the equipment resumes the initial stage of the maintenance mode.

5.2 LIST OF MAINTENANCE-MODE FUNCTIONS

Maintenance-mode Functions

Function Code	Function	Reference Subsection (Page)
01	EEPROM Parameter Initialization	5.3.1 (5-4)
05	Printout of Scanning Compensation Data	5.3.2 (5-5)
08	ADF* Performance Test	5.3.3 (5-7)
09	Test Pattern 1	5.3.4 (5-8)
10	Firmware Switch Setting	5.3.5 (5-9)
11	Printout of Firmware Switch Data	5.3.5 (5-11)
12	Operational Check of LCD	5.3.6 (5-12)
13	Operational Check of Control Panel PCB (Check of Keys and Buttons)	5.3.7 (5-13)
16	Receiver Volume Adjustment (Applicable to the FAX1800C)	5.3.8 (5-15)
32	Sensor Operational Check	5.3.9 (5-16)
54	Fine Adjustment of Scanning Start/End Position	5.3.10 (5-17)
55	CIS Scanner Area Setting	5.3.11 (5-18)
57	Setting the Sensing Reference Level of the Ink Empty Sensor	5.3.12 (5-19)
65	Alignment of Vertical Print Lines	5.3.13 (5-20)
68	Updating of Head Property Information	5.3.14 (5-22)
69	Initial Adjustment of PWM Value (Aging of the carriage)	5.3.15 (5-23)
74	EEPROM Customizing	5.3.16 (5-24)
80	Display of the Equipment's Log Information	5.3.17 (5-25)
82	Equipment Error Code Indication	5.3.18 (5-26)
87	Output of Transmission Log to the Telephone Line	5.3.19 (5-26)
91	EEPROM Parameter Initialization (except the telephone number storage area)	5.3.1 (5-4)
99	Exit from the Maintenance Mode	---- (5-1)
—	Cancellation of the Pin TX Lock Mode (Not applicable to the American models)	5.3.20 (5-27)

* ADF: Automatic document feeder

----- **IMPORTANT** -----

Basically, the maintenance-mode functions listed on the previous page should be accessed by service personnel only. However, you may allow end users to access some of these under the guidance of service personnel (e.g., by telephone).

The user-accessible functions (codes 10, 11, 12, 54, 65, 80, 82, 87 and 91) are shaded in the table given on the previous page. Function code 10 accesses the firmware switches, each of which has eight selectors. You should not allow end users to access all of those selectors, but you may allow them to access user-accessible selectors which are shaded in the firmware switch tables in Appendix 2.

The service personnel should instruct end users to follow the procedure given below.

- (1) American models: Press the **Menu** and **Receive Mode** keys in this order.
European models: Press the **Menu** and **Tel/R** keys in this order.
The LCD clears the current display.
NOTE: The **Receive Mode** or **Tel/R** key is disabled during standby for redialing and timer.
- (2) Press the **0** key.
- (3) Enter the desired function code (10, 11, 12, 54, 65, 80, 82, 87, or 91) with the numerical keys.
For function code 10, access the desired firmware switch according to the operating procedure described in Appendix 2.
- (4) To make the equipment return to the standby state, press the **Stop** key.

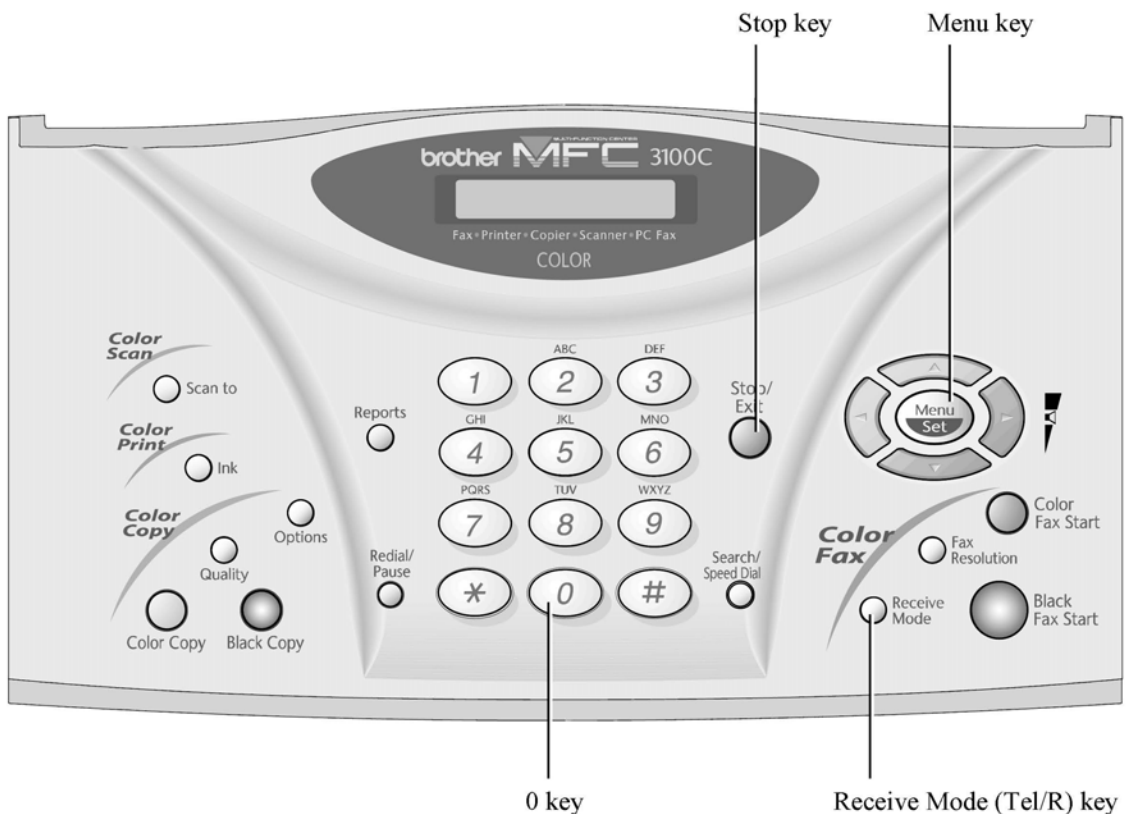

5.3 DETAILED DESCRIPTION OF MAINTENANCE-MODE FUNCTIONS

5.3.1 EEPROM Parameter Initialization

■ Function

The equipment initializes the parameters, user switches, and firmware switches registered in the EEPROM, to the initial values. Entering the function code 01 initializes almost all of the EEPROM areas, but entering 91 does not initialize some areas, as listed below.

Data item \ Function code	01	91
Maintenance-mode functions	All of these will be initialized	These will be initialized
User switches		
Firmware switches		
Remote activation code		
Activity report		These will <u>not</u> be initialized
Station ID data		
Outside line number		
Telephone function registration		
One-touch dialing		
Speed dialing		
Group dialing		
EEPROM customizing code (4-digit)	This will <u>not</u> be initialized. (Note that the first digit of the 4-digit code will be initialized to "0." If the code is <u>1001</u> , for example, it will be initialized to <u>0001</u> .)	

NOTE: you replace the main PCB with one used for other facsimile equipment, carry out this procedure and then customize the EEPROM (maintenance-mode function code 74 in Section 5.3.16).

■ Operating Procedure

- (1) Press the **0** and **1** keys (or the **9** and **1** keys according to your need) in this order in the initial stage of the maintenance mode.
The "PARAMETER INIT" will appear on the LCD.
- (2) Upon completion of parameter initialization, the equipment returns to the initial stage of the maintenance mode.

5.3.2 Printout of Scanning Compensation Data

■ Function

The equipment prints out the white and black level data for scanning compensation.

■ Operating Procedure

Do not start this function merely after powering on the equipment but start it after carrying out a sequence of scanning operation. Unless the equipment has carried out any scanning operation, this function cannot print out correct scanning compensation data. This is because at the start of scanning operation, the equipment initializes white and black level data and takes in the scanning compensation reference data.

- (1) Press the **0** and **5** keys in this order in the initial stage of the maintenance mode.
The "WHITE LEVEL 1" will appear on the LCD.
- (2) The equipment prints out the scanning compensation data list containing the following:
 - a) LED PWM data for color print (1 byte)
 - b) LED PWM data for monochrome print (1 byte)
 - c) Green LED pulse data (2 bytes)
 - d) Blue LED pulse data (2 bytes)
 - e) Red LED pulse data (2 bytes)
 - f) A/D converter reference level for high value (1 byte)
 - g) A/D converter reference level for low value (1 byte)
 - h) Compensation data for background color (1 byte)
 - i) Black level data (2448 bytes)
 - j) White level data for red image (2464 bytes)
 - k) White level data for green image (2464 bytes)
 - l) White level data for blue image (2464 bytes)
- (3) Upon completion of recording of the compensation data list, the equipment returns to the initial stage of the maintenance mode.

NOTE: When the equipment prints monochrome images after monochrome scanning, only the green data is valid.

NOTE: If any data is abnormal, its code will be printed in inline style, as shown on the next page.

2001-02-05-17:46

a)	4004e3e6	: 48
b)	4004e3e7	: 2c
c)	4004e3dc	: 06a1
d)	4004e3de	: 05f6
e)	4004e3e0	: 0a74
f)	4004e3d6	
g)	4004e3d9	: 507ca000 : 0a 12 13 0b 0a 12 10 16 0c 0b 14 12 10 12 14 12
h)	4004e3ec	: 507ca020 : 0a 0b 15 0a 0e 06 16 0f 09 0d 0b 0c 0d 0f 06 0e
507	507ca800	: 0f 12 10 0c 08 14 11 10 0d 12 13 10 10 0e 13 14
507	507ca820	: 13 0b 14 0d 14 10 10 12 10 14 0f 0d 12 12 0f 15
507	507cb000	: 11 0c 0d 11 11 0c 0b 09 0c 12 12 10 10 0c 0e 0c
507	507cb020	: 0d 0e 06 0b 09 19 16 14 0b 14 14 0f 10 0d 0e 15
507	507c4000	: 55 6b 6f 6a 6a 6f 68 62 63 67 71 70 6c 6c 62 6b
507	507c4020	: 68 6d 76 69 6a 5b 6a 6c 68 6e 6c 69 64 68 62 6b
507	507c4040	: 71 70 6f 69 68 69 6a 6a 67 65 68 64 67 6f 6f 6a
507	507c4060	: 69 61 5f 5c 61 70 6a 69 6c 5f 60 6a 68 6a 6e 6a
507	507c4080	: 5d 5c 64 6c 6b 74 6c 62 60 60 65 64 6c 6e 68 5e
507	507c40a0	: 63 63 69 69 67 60 63 5c 67 5e 6c 6f 71 6c 65 6e
507	507c40c0	: 70 6f 6f 6a 69 5f 67 6a 69 68 6d 64 68 65 6b 6c
507	507c40e0	: 6e 68 73 66 64 64 64 6a 6d 6c 65 61 69 6d 70 77
507	507c4100	: 6b 68 5d 5f 69 6e 6e 6c 6a 69 64 68 6c 6e 61 66
507	507c4120	: 5e 5c 66 61 69 64 65 66 54 5f 64 60 62 65 5e 4c
507	507c4140	: 62 5a 5e 56 5e 60 54 57 54 4a 3e
507	507c4160	
507	507c4180	
507	507c41a0	
507	507c41c0	
507	507c41e0	
507	507c4200	
507	507c4000	: 68 68 63 63 67 60 63 5c 67 5e 6c 6f 71 6c 65 6e
507	507c4020	: 70 6f 6f 6a 69 5f 67 6a 69 68 6d 64 68 65 6b 6c
507	507c3800	: 6d 6a 68 6a 6d 66 6a 69 6c 70 6e 6a 68 69 6e 6d
507	507c3820	: 6d 6b 5e 65 67 77 77 74 69 6d 6e 6d 6e 68 6b 72
507	507c3840	: 6f 6a 6a 6d 70 74 6d 6d 65 70 6c 6d 6e 72 6c 6e
507	507c3860	: 73 74 74 72 75 71 72 5e 74 72 7a 72 73 68 65 65
507	507c3880	: 6e 70 6a 71 6a 68 6c 6d 6e 6c 6e 72 61 66 6c 71
507	507c38a0	: 70 6d 6a 65 60 6c 5f 66 67 67 5e 68 64 67 6a 70
507	507c38c0	: 6a 66 65 67 67 6d 6e 67 67 5e 64 66 64 62 68 63
507	507c38e0	: 5f 60 65 64 63 68 60 5e 61 5f 66 62 65 67 5f 60
507	507c3900	: 57 64 68 66 65 60 5c 5e 5c 66 63 66 5e 5c 6c 68
507	507c3920	: 6a 60 63 64 5c 60 60 61 67 62 60 5a 58 5c 5c 5a
507	507c3940	: 63 5d 5c 5d 5a 62 66 63 66 60 58 5a 68 6e 60 6c
507	507c3960	: 64 62 5e 68 6c 67 65 65 6c 6a 66 68 68 67 75 69
507	507c3980	: 65 6c 69 72 70 6d 6a 6a 74 71 72 71 70 71 79 6c
507	507c39a0	: 76 79 72 75 71 76 6d 70 6c 75 77 74 74 72 74 78
507	507c39c0	: 7e 77 71 71 72 6c 73 77 76 7a 6e 6d 69 65 6f 74
507	507c39e0	: 6f 71 6b 69 6e 71 75 7b 77 74 6f 71 70 79 7c 7c
507	507c3a00	: 70 6d 6e 6e 70 75 7e 77 70 71 78 72 7a 7a 70 78
507	507c3a20	: 73 6f 6c 75 76 76 74 6e 6f 75 76 79 7a 76 6c 6d
507	507c3a40	: 76 70 74 72 71 6e 6f 66 6d 6d 73 74 70 65 65 68
507	507c3a60	: 6e 6d 72 6c 6c 68 6a 6e 72 6e 6c 67 68 68 68 6e
507	507c3a80	: 65 66 63 6b 68 70 6e 71 72 66 62 67 66 6c 6d 70
507	507c3aa0	: 6b 6a 71 62 6a 6e 65 67 69 65 6d 6c 73 6b 6e 6e
507	507c3ac0	: 68 64 6b 67 6f 6a 66 5b 65 6a 6d 73 6d 6c 66 5e
507	507c3ae0	: 65 67 69 71 65 65 65 63 65 66 6b 68 68 5e 62 6e
507	507c3b00	: 69 6e 67 5c 61 5d 63 60 62 6c 61 5f 5f 66 69 6a

Scanning Compensation Data List

5.3.3 ADF Performance Test

■ Function

The equipment counts the documents fed by the automatic document feeder (ADF) and displays the count on the LCD for checking the ADF performance.

■ Operating Procedure

- (1) Set documents. (Allowable up to the ADF capacity.)

The "DOC. READY" will appear on the LCD.

- (2) Press the **0** and **8** keys in this order.

While counting the documents, the equipment feeds them in and out, displaying the current count on the LCD as shown below.

ADF CHECK P.01

↑
— Current count (1st page in this example)

- (3) After counting all documents, the equipment shows the final count. To return the equipment to the initial stage of the maintenance mode, press the **Stop** key.

5.3.4 Test Pattern 1

■ Function

This function, much like the copying function, prints out test pattern 1 to allow the service personnel to check for record data missing or print quality.

■ Operating Procedure

Press the 0 and 9 keys in this order in the initial stage of the maintenance mode.

The figure below shows test pattern 1.

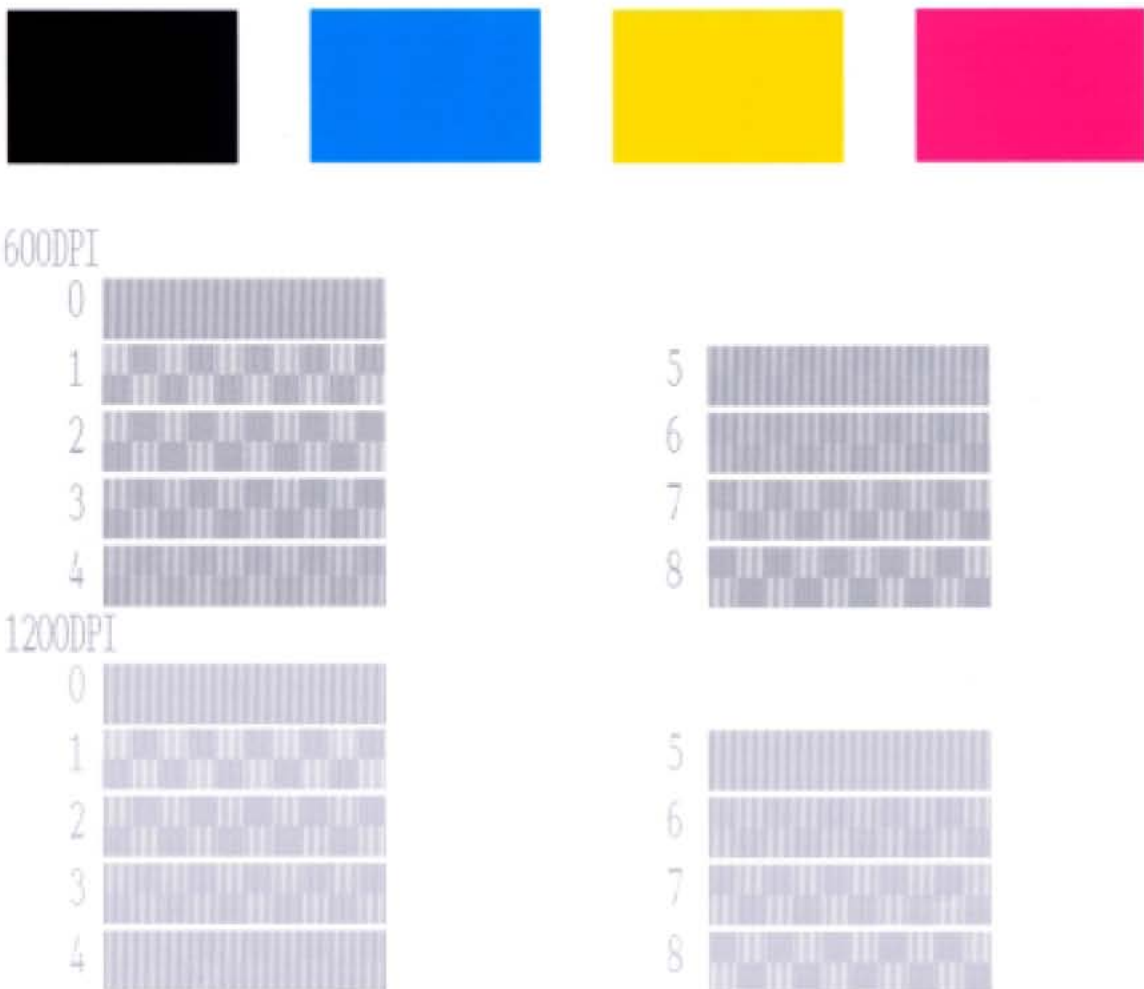

Test Pattern 1

5.3.5 Firmware Switch Setting and Printout

[A] Firmware switch setting

■ Function

The facsimile equipment incorporates the following firmware switch functions which may be activated with the procedures using the control panel keys and buttons.

The firmware switches have been set at the factory in conformity to the communications standards and codes of each country. Do not disturb them unless necessary. Some firmware switches may not be applicable in some versions. The firmware switch data list indicates "Not used." for those inapplicable switches.

Firmware Switches (WSW01 through WSW50)

WSW No.	Function
WSW01	Dial pulse setting
WSW02	Tone signal setting
WSW03	PABX mode setting
WSW04	TRANSFER facility setting
WSW05	1st dial tone and busy tone detection
WSW06	Pause key setting and 2nd dial tone detection
WSW07	Dial tone setting 1
WSW08	Dial tone setting 2
WSW09	Protocol definition 1
WSW10	Protocol definition 2
WSW11	Busy tone setting
WSW12	Signal detection condition setting
WSW13	Modem setting
WSW14	AUTO ANS facility setting
WSW15	REDIAL facility setting
WSW16	Function setting 1
WSW17	Function setting 2
WSW18	Function setting 3
WSW19	Transmission speed setting
WSW20	Overseas communications mode setting
WSW21	TAD setting 1
WSW22	ECM and copy resolution setting
WSW23	Communications setting
WSW24	TAD setting 2
WSW25	TAD setting 3
WSW26	Function setting 4
WSW27	Function setting 5
WSW28	Function setting 6
WSW29	Function setting 7
WSW30	Not used.
WSW31	Function setting 9
WSW32	Function setting 10
WSW33	Function setting 11

Firmware Switches (WSW01 through WSW50) *Continued*

WSW No.	Function
WSW34	Function setting 12
WSW35	Not used.
WSW36	Function setting 14
WSW37	Function setting 15
WSW38	Not used.
WSW39	Not used.
WSW40	Not used.
WSW41	Not used.
WSW42	Function setting 20
WSW43	Function setting 21
WSW44	Not used.
WSW45	Not used.
WSW46	Monitor of power ON/OFF state and parallel port kept at high
WSW47	Paper handling for a feed error and delay of FAX line disconnection
WSW48	Not used.
WSW49	Not used.
WSW50	Not used.

■ Operating Procedure

- (1) Press the **1** and **0** keys in this order in the initial stage of the maintenance mode.
The equipment displays the "WSW00" on the LCD and becomes ready to accept a firmware switch number.
- (2) Enter the desired number from the firmware switch numbers (01 through 50).
The following appears on the LCD:

Selector 1	Selector 8
↓	↓
WSWXX = <u>0</u> 0 0 0 0 0 0 0	
- (3) Use the right and left arrow keys to move the cursor to the selector position to be modified.
- (4) Enter the desired number using the **0** and **1** keys.
- (5) Press the **Set** key. This operation saves the newly entered selector values onto the EEPROM and readies the equipment for accepting a firmware switch number.
- (6) Repeat steps (2) through (5) until the modification for the desired firmware switches is completed.
- (7) Press the **Set** or **Stop** key to return the equipment to the initial stage of the maintenance mode.

NOTES:

- To cancel this operation and return the equipment to the initial stage of the maintenance mode during the above procedure, press the **Stop** key.
- If there is a pause of more than one minute after a single-digit number is entered for double-digit firmware switch numbers, the equipment will automatically return to the initial stage of the maintenance mode.

■ Details of Firmware Switches

The details of the firmware switches are described in Appendix 2 in which the user-accessible selectors of the firmware switches are shaded.

[B] Printout of firmware switch data

■ Function

The equipment prints out the setting items and contents specified by the firmware switches.

■ Operating Procedure

- (1) Press the 1 key twice in the initial stage of the maintenance mode.
The "PRINTING" will appear on the LCD.
- (2) The equipment prints out the configuration list as shown in the figure below.
- (3) Upon completion of printing, the equipment returns to the initial stage of the maintenance mode.

CONFIGURATION LIST

MODEL : 8XA-401
TIME : 06/25/2001 17:50
REV. : U0106130955VER.0
PCI : 5.00
SUM : 0011
SER.# : BROF19000122

```
WSW01 = 00000010  
WSW02 = 11111010  
WSW03 = 10000000  
WSW04 = 00010111  
WSW05 = 00000110  
WSW06 = 00101100  
WSW07 = 01001100  
WSW08 = 01100100  
WSW09 = 00000000  
WSW10 = 00010100  
WSW11 = 01011000  
WSW12 = 10011011  
WSW13 = 00011010  
WSW14 = 01100111  
WSW15 = 00001110  
WSW16 = 01100010  
WSW17 = 00100011  
WSW18 = 10001010  
WSW19 = 11100000  
WSW20 = 10011111  
WSW21 = 00101000  
WSW22 = 00100000  
WSW23 = 00001110  
WSW24 = 01000010  
WSW25 = 00011010  
WSW26 = 00110010  
WSW27 = 00100001  
WSW28 = 00000000  
WSW29 = 01101001  
WSW30 = 10000000  
WSW31 = 11100101  
WSW32 = 01010000  
WSW33 = 10000010  
WSW34 = 00010000  
WSW35 = 01000000  
WSW36 = 00001000  
WSW37 = 10000101  
WSW38 = 00010100  
WSW39 = 11110000  
WSW40 = 00000000  
WSW41 = 00000111  
WSW42 = 11110100  
WSW43 = 00000001  
WSW44 = 00000010  
WSW45 = 00000000  
WSW46 = 00000000  
WSW47 = 00000000  
WSW48 = 00000000  
WSW49 = 00000000  
WSW50 = 00000000
```

Configuration List

5.3.6 Operational Check of LCD

■ Function

This function allows you to check whether the LCD on the control panel works normally.

■ Operating Procedure

- (1) Press the **1** and **2** keys in this order in the initial stage of the maintenance mode.

The LCD shows the screen given at right.

- (2) Press the **Black Fax Start** key. Each time you press the **Black Fax Start** key, the LCD cycles through the displays shown at right.

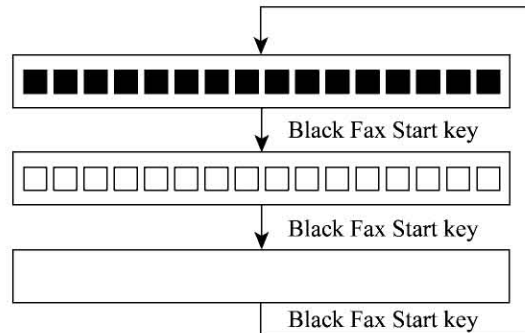

- (3) Press the **Stop** key in any process of the above display cycle. The equipment beeps for one second and returns to the initial stage of the maintenance mode.

5.3.7 Operational Check of Control Panel PCB

■ Function

This function allows you to check the control panel PCB for normal operation.

■ Operating Procedure

- (1) Press the **1** and **3** keys in this order in the initial stage of the maintenance mode.

The "00 " will appear on the LCD.

- (2) Press the keys and buttons in the order designated in the illustration shown below.

The LCD shows the corresponding number in decimal notation each time a key or button is pressed. Check that the displayed number is correct by referring to the illustration below.

If a key or button is pressed out of order, the equipment beeps and displays the "INVALID OPERATE" on the LCD. To return to the status ready to accept key & button entry for operational check, press the **Stop** key.

- (3) After the last number key or button is pressed, the equipment beeps and returns to the initial stage of the maintenance mode.

To terminate this operation, press the **Stop** key. The equipment returns to the initial stage of the maintenance mode.

MFC3100C/MFC580

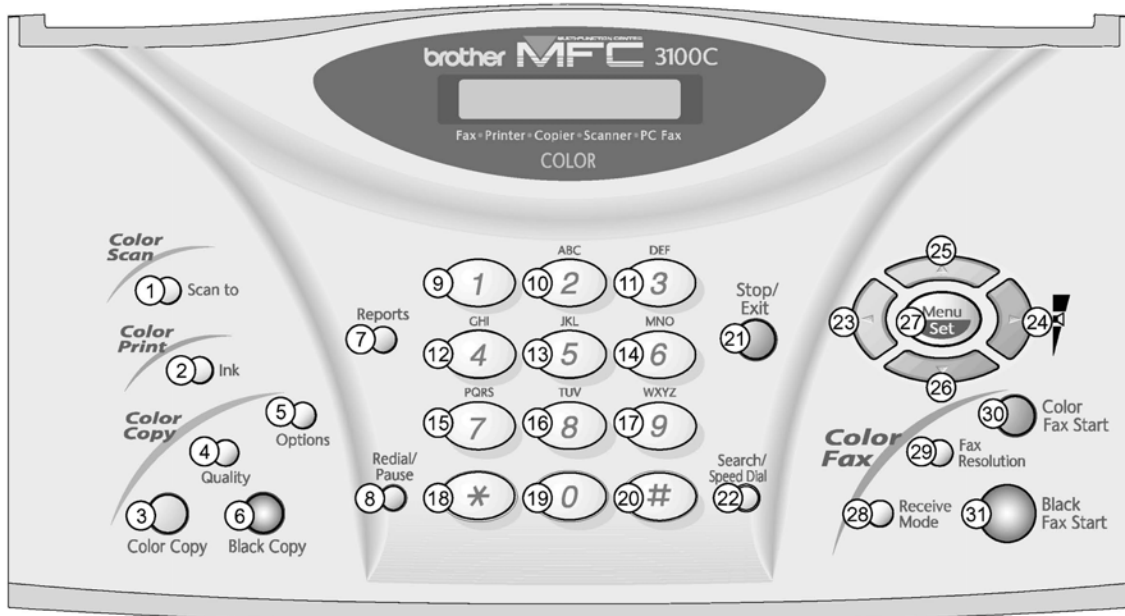

Key & Button Entry Order (1)

FAX1800C

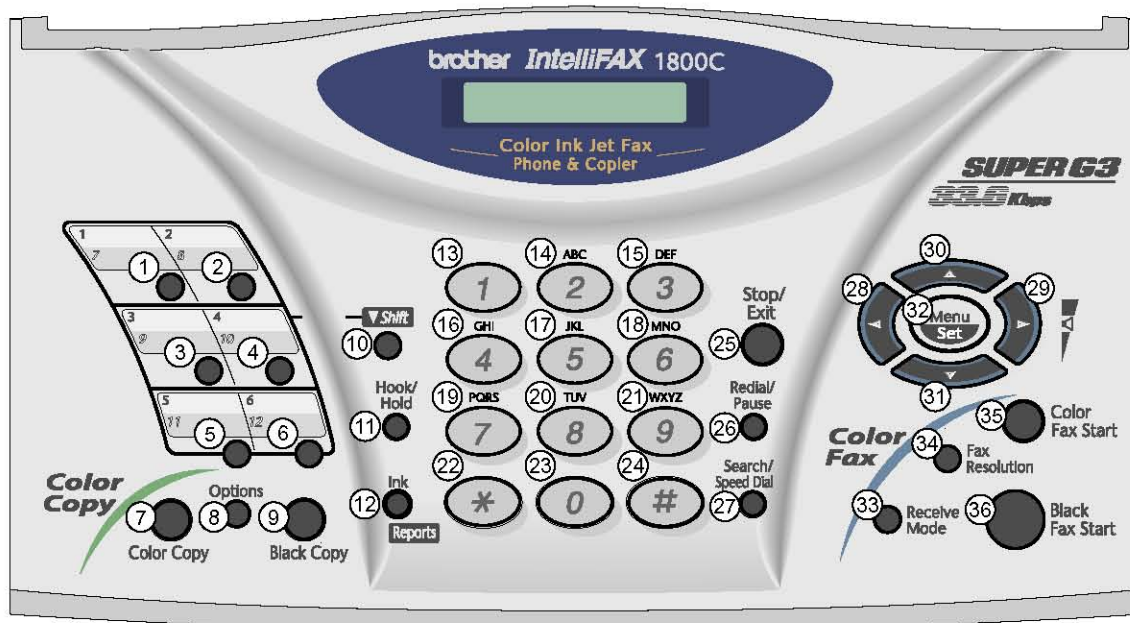

Key & Button Entry Order (2)

5.3.8 Receiver Volume Adjustment (Applicable to the FAX1800C)

■ Function

The HIGH level of the handset receiver's volume will be influenced by the characteristics of the FET on the main PCB, so it requires fine adjustment according to the procedure given below.

■ Operating Procedure

- (1) Connect the telephone line cord to the modular jack of the facsimile equipment and the telephone wall socket.
- (2) Pick up the handset and listen to the dial tone. If the receiver volume is not appropriate, proceed to the following steps:
- (3) Press the **1** and **6** keys in this order in the initial stage of the maintenance mode.

The LCD shows the current receiver volume (default: HIGH).

- (4) If the current receiver volume is not HIGH, use the right or left arrow key to choose HIGH.
- (5) Press the **Start** key.

The equipment enters the receiver volume adjustment mode and shows the PWM duty ratio at the right end of the LCD.

- (6) Adjust the receiver volume by using the **1**, **3**, **4**, or **6** key.

1 key: Decrease 10H

3 key: Increase 10 H

4 key: Decrease 1H

6 key: Increase 1H

- (7) To escape from the receiver volume adjustment mode, press the **Set** key.

The LCD shows the "PWM SETTING." One second later, the LCD returns to the screen shown in step (3).

- (8) To return the equipment to the initial stage of the maintenance mode, press the **Stop** key.

5.3.9 Sensor Operational Check

■ Function

This function allows you to check the following:

- Document front sensor
- Document rear sensor
- Cover/panel open sensor
- Registration sensor
- Paper width sensor
- Purge cam HP switch
- Pump switching cam HP switch
- Head dimple contact
- Black ink cartridge sensor
- Yellow ink cartridge sensor
- Cyan ink cartridge sensor
- Magenta ink cartridge sensor
- Head driver chip temperature sensors
- Hook switch*

(*Provided in the FAX1800C)

■ Operating Procedure

- (1) Press the **3** and **2** keys in this order in the initial stage of the maintenance mode. The equipment sounds 1100 Hz and 400 Hz tones cyclically through the following volumes for testing the speaker:

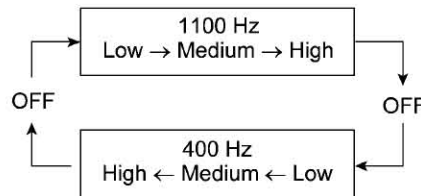

NOTE: To stop beeping, press the **Menu** key.

If the sensing status are as listed below, the LCD will show the following two letter strings which can be switched by pressing the **Black Fax Start** key:

MFC3100C/MFC580: "DFDRCVRSPPWP1P2HD" and "IKIYICIMVT"

FAX1800C: "HKDFDRCVRSPPWHDVT" and "P1P2IKIYICIM"

Given below is the relationship between the LCD indication, sensor name and sensor status.

LCD	Sensors	Sensing status
HK	Hook switch*	On-hook state.
DF	Document front sensor	No document detected.
DR	Document rear sensor	No document detected.
CV	Cover/panel open sensor	Top cover and control panel ASSY closed.
RS	Registration sensor	No recording paper detected.
PW	Paper width sensor	No paper detected.
P1	Purge cam HP switch	Purge cam placed in the home position.
P2	Pump switching cam HP switch	Pump switching cam placed in the home position.
HD	Head dimple contact	Head detected.
IK	Black ink cartridge sensor	Black ink cartridge loaded.
IY	Yellow ink cartridge sensor	Yellow ink cartridge loaded.
IC	Cyan ink cartridge sensor	Cyan ink cartridge loaded.
IM	Magenta ink cartridge sensor	Magenta ink cartridge loaded.
VT	Head driver chip temperature sensors	Driver chip temperature within the allowable range

- (2) Change the detecting conditions (e.g., pick up the handset*, insert paper through the document sensors, registration sensor or paper width sensor, open the top cover or control panel ASSY, and remove the print head or ink cartridges) and then check that the indication on the LCD changes according to the sensor states.
- (3) To stop this operation and return the equipment to the initial stage of the maintenance mode, press the **Stop** key.

5.3.10 Fine Adjustment of Scanning Start/End Position

■ Function

This function allows you to adjust the scanning start/end position.

■ Operating Procedure

- (1) Press the **5** and **4** keys in this order in the initial stage of the maintenance mode.

The "SCAN START ADJ." appears on the LCD. After two seconds, the current scanning position correction value appears.

You may adjust the correction value to 11 levels from +5 to -5 (mm).

- (2) To increase the correction value, press the left arrow key; to decrease it, press the right arrow key.

If you press the **Stop** key, the equipment returns to the initial stage of the maintenance mode without making change of the correction value.

- (3) Press the **Set** key.

The "ACCEPTED" appears on the LCD. After one second, the equipment returns to the initial stage of the maintenance mode.

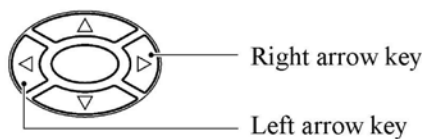
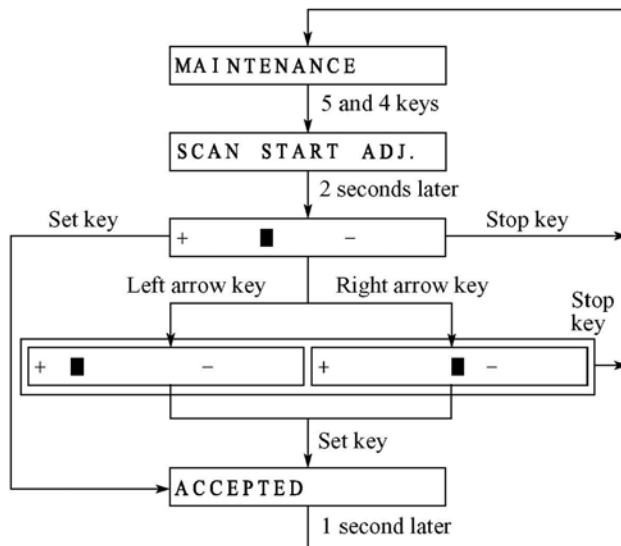

NOTE: The relationship between the scanning start/end positions and their correction values is shown below.

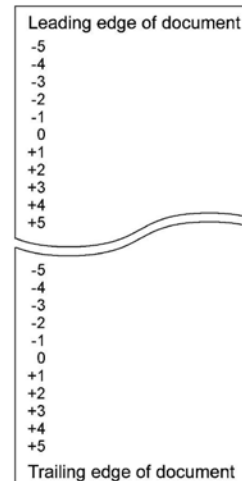

5.3.11 CIS Scanner Area Setting

■ Function

The equipment sets the CIS scanner area and stores it into the EEPROM.

■ Operating Procedure

(1) Press the **5** key twice in the initial stage of the maintenance mode.

The "SCANNER AREA SET" will appear on the LCD.

The equipment checks and sets the area to be scanned.

If no error is noted, the equipment returns to the initial stage of the maintenance mode.

If any error is noted, the "SCANNER ERROR" will appear on the LCD. To return the equipment to the initial stage of the maintenance mode, press the **Stop** key.

5.3.12 Setting the Sensing Reference Level of the Ink Empty Sensor

■ Function

This function allows you to set the sensing reference level of the ink empty sensor which apply when the controller judges whether there is ink in the ink cartridge. The setting procedure requires a foam-empty cartridge as a reference cartridge.

NOTE: If you replace the main PCB or ink empty sensor, carry out this procedure.

■ Operating Procedure

Handling notes for the reference cartridge: Shown below is a foam-empty cartridge to be used for setting the sensing reference level of the ink empty sensor. Do not touch section "x" or "y."

If any dust or dirt is found on "x" or "y," wipe it off with a soft cloth. If "x" is scratched, replace the cartridge with a new one. Using such a scratched cartridge will fail to set correct reference level. After completion of the setting procedure, store the cartridge in the container.

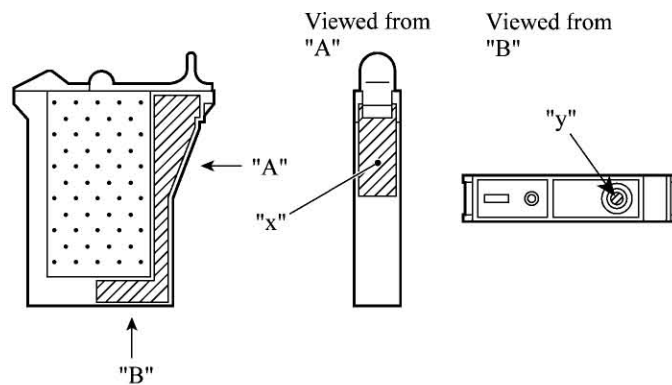

Foam-empty cartridge

- (1) Press the 5 and 7 keys in this order in the initial stage of the maintenance mode.
- (2) Open the control panel and top cover.
The carriage automatically moves left to the ink replacement position.
- (3) Remove the yellow ink cartridge.
The LCD shows "SET F.EMP CART!!."
NOTE: When this message is displayed, do not load or unload any other ink cartridges.
- (4) Set the foam-empty cartridge into the yellow ink cartridge position.
The LCD shows "CLOSE COVER!!."
- (5) Close the top cover and control panel.
The equipment shows the "-INKEMP CHECK-" and starts setting the sensing level for the foam-empty cartridge.
If the equipment completes setting normally, it beeps and displays the "INKEMP TST:OK!."
If it fails, the "INKEMP F.EMP:NG!" appears, so press the Stop key and go back to step (1).
- (6) Open the control panel and top cover, and remove the foam-empty cartridge.
- (7) Load the yellow ink cartridge removed in step (3) back into place.
- (8) Press the Stop key to return to the initial stage of the maintenance mode.

5.3.13 Alignment of Vertical Print Lines

■ Function

This function allows you to align vertical lines printed in the forward and backward direction of the carriage.

NOTE: Before this alignment job, be sure to correct the positioning error of the print head. Refer to CHAPTER 4, Section 4.3 "ADJUSTMENT."

■ Operating Procedure

- (1) Press the **6** and **5** keys in this order in the initial stage of the maintenance mode.
The equipment prints out a set of vertical alignment check patterns which consist of No. 1 to No. 9 lines for each of the 600 dpi and 1200 dpi.
If the vertical alignment is ON, No. 5 line (each in the 600 dpi and 1200 dpi printouts) shows vertically aligned lines as given on the next page.
The LCD shows the "600DPI NO.(1-9)."
- (2) Check the printed vertical alignment check patterns for the 600 dpi and find which number line shows full alignment. If the line is other than No. 5, enter that line number by using the numerical keys.
The LCD shows the "1200DPI NO.(1-9)."
- (3) For the 1200 dpi, perform the same operation as in step (2).
The equipment automatically returns to the initial stage of the maintenance mode.

NOTE: If No. 1 line or No. 9 line is fully aligned so that you press the **1** or **9** key in the above procedure, then go back to step (1) to confirm that No. 5 line becomes aligned.

600DPI

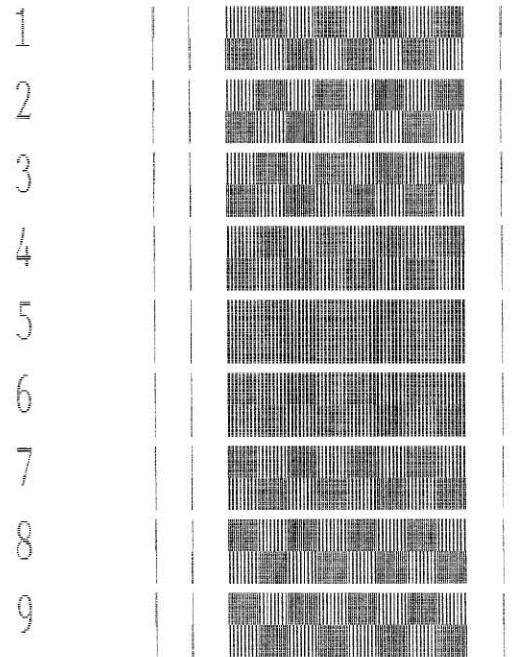

1200DPI

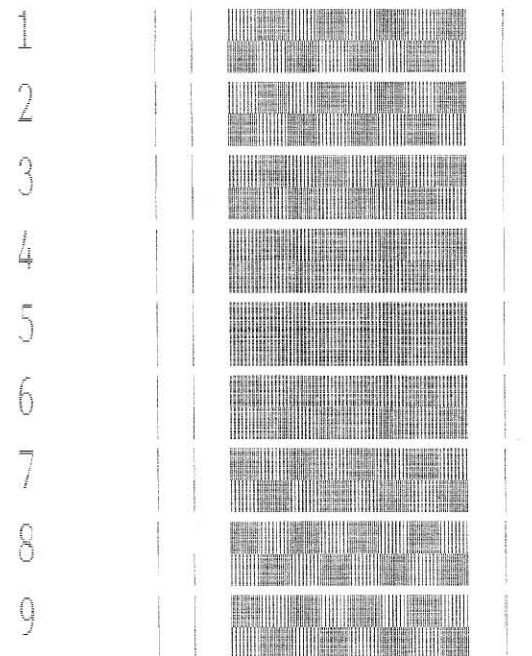

Vertical Alignment Check Pattern

5.3.14 Updating of Head Property Information

■ Function

To keep the print quality, the controller optimizes the head drive strength, ink jet-out timing, and other drive conditions according to the electromechanical properties unique to individual print heads and ambient temperature. The head property information is stored in the EEPROM of the main PCB.

If you replace the print head unit and/or main PCB of the machine, then you need to update the head property according to the procedure given here.

TIP: You may update the head property information from a PC connected to the facsimile machine. For the procedure, refer to CHAPTER 2, Section 2.3.

■ Operating Procedure

- (1) Press the **6** and **8** keys in this order in the initial stage of the maintenance mode.
- (2) Press the **2, 5, 8, 0** keys in this order.

The facsimile machine shows the current head property information (13-digit code, e.g., 45352DABB485F) stored in the EEPROM on the LCD and becomes ready to accept entry.

- (3) Check the head property code printed on the bar code label attached to the print head unit. Out of the 13-digit property code (enclosed with asterisks, e.g., *66667F657031H*), type upper 12 digits (e.g., 66667F657031).

NOTE: To enter letters "A" through "F," press the 1 through 6 keys while holding down the # key, respectively.

- (4) Press the **Set** key.

The machine beeps, shows the "INPUT ACCEPTED" on the LCD, and writes the entered property code into the EEPROM. Then the machine returns to the initial stage of the maintenance mode.

NOTE: If the entered data contains any checksum error, the machine beeps, shows the "INPUT ERROR," and then returns to the ready-to-enter state. Go back to step (3).

5.3.15 Initial Adjustment of PWM Value (Aging of the Carriage)

■ Function

This function obtains the initial value of the PWM by aging the carriage and writes it onto the EEPROM, as well as checking the head drive voltage level.

This aging procedure should be performed if you replace the print head, carriage ASSY, carriage motor, or encoder strip or if you loosen the timing belt.

NOTE: Opening the top cover or the control panel during the aging procedure will result in an error. If you perform this aging procedure with either of them opened, the equipment will slowly age the carriage resulting in an error after completion of the aging.

■ Operating Procedure

- (1) Press the 6 and 9 keys in this order in the initial stage of the maintenance mode.

The equipment starts aging the carriage, showing the "CR AGING" on the LCD.

After writing the initial value of the PWM onto the EEPROM and checking the head drive voltage level, the equipment automatically returns to the initial stage of the maintenance mode.

If any error occurs, the equipment beeps and shows some message, e.g., "OK30 NG15 NG07" on the LCD. This sample message indicates that the speed variation is within the allowable range when the carriage travels at high speed of 30 inches/sec.; however, it is out of the range at medium or low speed of 15 inches/sec. or 7 inches/sec.

To return to the initial stage of the maintenance mode, press the **Stop** key.

5.3.16 EEPROM Customizing

■ Function

This function allows you to customize the EEPROM according to language, function settings, and firmware switch settings. The customizing codes list is given in Appendix 1.

NOTE: If you replace the main PCB, be sure to carry out this procedure.

■ Operating Procedure

- (1) Press the **7** and **4** keys in this order in the initial stage of the maintenance mode.

The current customizing code (e.g., B001 in the case of MFC3100C U.S.A. versions) appears.

- (2) Enter the desired customizing code (e.g., 2002 in the case of MFC3100C Canadian versions).

NOTE: To enter letters "A" through "F," press the **1** through **6** keys while holding down the **#** key, respectively.

The newly entered code appears.

NOTE: *If a wrong 4-digit code is entered, the equipment will malfunction.*

- (3) Press the **Black Fax Start** key.

The equipment saves the setting and returns to the initial stage of the maintenance mode.

If you press the **Stop** key or no keys are pressed for one minute in the above procedure, the equipment stops the procedure and returns to the initial stage of the maintenance mode.

5.3.17 Display of the Equipment's Log Information

■ Function

The equipment may display the its log information on the LCD.

■ Operating Procedure

- (1) Press the **8** and **0** keys in this order in the initial stage of the maintenance mode.
The USB serial number appears on the LCD.
- (2) Press the **Black Fax Start** key. Each time the **Black Fax Start** key is pressed, one of the following log information items appears on the LCD in the order given below.
 - 1) Ink cartridge drop count, indicating how many droplets have been jetted out from each of the ink cartridges*¹
 - 2) Ink drop count after near-empty, indicating how many droplets have been jetted out from each of the ink cartridges*¹ after the ink empty sensor detects near-empty
 - 3) Total ink drop count, indicating how many droplets the equipment has been jetted out from each of the ink cartridges*¹ since produced
 - 4) Jam count, indicating how many times a paper jam has been occurred
 - 5) Total page count, indicating how many pages have been printed since the equipment was produced
 - 6) PC print page count, indicating how many pages the equipment has been printed as an output device of the connected PC
 - 7) Copy page count, indicating how many copies have been made
 - 8) FAX page count, indicating how many received FAX pages have been printed
 - 9) Purge count, indicating how many times the purge operation has been carried out
 - 10) Wiper count, indicating how many times the wiper operation has been carried out
 - 11) Ink cartridge change count, indicating how many times ink cartridge replacement has been made for each color*¹
 - 12) Error code of the most recent machine error*²
 - 13) Error code of the most recent communications error*³
 - 14) ADF jam count, indicating how many times a document jam has been occurred
 - 15) ADF page count, indicating how many documents have been fed
- (3) To stop this operation and return to the equipment to the initial stage of the maintenance mode, press the **Stop** key.

*¹ To check each of the four ink cartridges, press the **Menu** key. Pressing the key cycles through black, yellow, cyan, and magenta.

*² When a machine error code is displayed, pressing the **Menu** key toggles between the latest error and 2nd latest error.

*³ When a communications error code is displayed, pressing the **Menu** key cycles through the latest error, 2nd latest error, and 3rd latest error.

5.3.18 Equipment Error Code Indication

■ Function

This function displays an error code of the last error on the LCD.

■ Operating Procedure

- (1) Press the **8** and **2** keys in this order in the initial stage of the maintenance mode.
The LCD shows the "MACHINE ERROR X X."
- (2) To stop this operation and return the equipment to the initial stage of the maintenance mode, press the **Stop** key.

5.3.19 Output of Transmission Log to the Telephone Line

■ Function

This function outputs the transmission log (that the equipment has stored about the latest transmission) to the telephone line. It allows the service personnel to receive the transmission log of the user's equipment at a remote location and use it for analyzing problems arising in the user's equipment.

■ Operating Procedure

- (1) If the user's equipment has a transmission-related problem, call the user's equipment at a remote location from your equipment.
- (2) If the line is connected, have the user perform the following:
 - 1) American models: Press the **Menu**, **Receive Mode**, and **0** keys in this order.
European models: Press the **Menu**, **Tel/R**, and **0** keys in this order.
 - 2) Press the **8** and **7** keys in this order.

The above operation makes the user's equipment send CNG to your equipment for sending the transmission log.
- (3) If you hear the CNG sent from the user's equipment, press the **Black Fax Start** key of your equipment.

Your equipment will start to receive the transmission log from the user's equipment.

5.3.20 Cancellation of the Pin TX Lock Mode (Not applicable to American models)

■ Function

This procedure can cancel the Pin TX lock mode. Use this procedure if the user forgets his/her password entered when setting the Pin TX lock mode so as not to exit from the mode.

NOTE: Carrying out this procedure will lose passwords previously entered but retain FAX messages received in the Pin TX lock mode.

■ Operating Procedure

- (1) When the PIN TX LOCK is displayed on the LCD, press the **Menu** and **#** keys *at the same time*. Within two seconds, start to press the **2**, **7**, **9**, **0**, and **0** keys.

The Pin TX lock mode will be canceled and the equipment returns to the calendar clock screen.

CHAPTER 6 ERROR INDICATION AND TROUBLESHOOTING

CONTENTS

6.1	ERROR INDICATION.....	6-1
6.1.1	Equipment Errors.....	6-1
[1]	Error messages on the LCD.....	6-1
[2]	Error codes shown in the "MACHINE ERROR <u>X</u> <u>X</u> " message.....	6-4
6.1.2	Communications Errors.....	6-8
6.2	TROUBLESHOOTING.....	6-15
6.2.1	Introduction.....	6-15
6.2.2	Precautions.....	6-15
6.2.3	Checking prior to Troubleshooting.....	6-15
6.2.4	Troubleshooting Procedures.....	6-17
[1]	Control panel related.....	6-17
[2]	Telephone related.....	6-17
[3]	Communications related.....	6-18
[4]	Paper/document feeding related.....	6-18
[5]	Print-image related.....	6-19
[6]	PC-driven printing.....	6-22

6.1 ERROR INDICATION

To help the user or the service personnel promptly locate the cause of a problem (if any), the facsimile equipment incorporates the self-diagnostic functions which display error messages for equipment errors and communications errors.

For the communications errors, the equipment also prints out the transmission verification report and the communications list.

6.1.1 Equipment Errors

If an equipment error occurs, the facsimile equipment emits an audible alarm (continuous beeping) for approximately 4 seconds and shows the error message on the LCD. For the error messages, see [1] below.

To display detailed error information, use the maintenance-mode function code 82 described in CHAPTER 5, Subsection 5.3.18 (that is, make the equipment enter the maintenance mode and then press the 8 and 2 keys). Following the MACHINE ERROR, one of the error codes listed in [2] will appear on the LCD.

[1] Error messages on the LCD

Messages on the LCD	Probable Cause
<p>CHECK CARTRIDGE</p> <p>Open cover, then reinstall ink cartridge.</p> <p>(These messages appear alternately.)</p>	<p>Any of the ink cartridges is not loaded.</p>
<p>CHECK DOCUMENT</p> <p>Remove documents, then press STOP KEY.</p> <p>(These messages appear alternately.)</p>	<p>■ Document jam</p> <p>(1) The document length exceeds the limitation (400 or 90 cm) registered by firmware switch WSW16. (Refer to Appendix 2.)</p> <p>(Both the document front and rear sensors stay ON even after the document has been fed by the registered length.)</p> <p>(2) The document rear sensor detects no trailing edge of a document after the document has been fed by 400 cm.</p> <p>(The document rear sensor stays ON even after the document has been fed when the document front and rear sensors were OFF and ON, respectively.)</p>

Messages on the LCD	Probable Cause
<p>CHECK DOCUMENT Remove documents, then press STOP KEY. (These messages appear alternately.)</p>	<p>■ Document loading error</p> <p>(1) The document rear sensor detects no leading edge of a document within 10 seconds from the start of document loading operation. (The document rear sensor stays OFF even after the document has been fed when the document front sensor was ON.)</p> <p>(2) The loaded document is too short. (Since the document is shorter than the distance between the document front and rear sensors, the document front sensor is turned OFF before the document rear sensor is turned ON.)</p>
<p>CHECK PAPER Reload paper, then press FAX START. (These messages appear alternately.)</p>	<p>The registration sensor detects no recording paper loaded in the auto sheet feeder (ASF).</p>
<p>COOLING DOWN WAIT FOR A WHILE (These messages appear alternately.)</p>	<p>The temperature inside the machine is too high.</p>
<p>COVER OPEN PLS CLOSE COVER (These messages appear alternately.)</p>	<p>The cover/panel open sensor detects that the top cover or control panel is not closed.</p>
<p>INK EMPTY CYAN INK EMPTY MAGENT INK EMPTY YELLOW INK EMPTY BLACK</p>	<p>The ink dot counter (for the indicated color) in the EEPROM on the main PCB has counted up the specified number of dots, meaning that the ink has run out. Once any of these messages is displayed, color printing is no longer possible.</p>
<p>LOW TEMPERATURE Room temperature is below spec. (These messages appear alternately.)</p>	<p>The temperature inside the machine is too low.</p>

Messages on the LCD	Probable Cause
NEAR EMPTY CYAN NEAR EMPTY MGENT NEAR EMPTY YELLW NEAR EMPTY BLACK	The ink empty sensor detects that the ink cartridge (cyan, magenta, yellow, or black) is near empty. Even if any of these messages is displayed, color printing is still possible.
PAPER JAM Open cover, then remove jammed paper. (These messages appear alternately.)	The registration sensor detects that a paper jam has occurred.
PC BUSY OR FAIL	After connected with the host computer, the equipment has received no response from the computer. (A communications error has occurred.)
PLS OPEN COVER	To display the relating detailed error code, use maintenance-mode function code 82. (Refer to CHAPTER 5, Subsection 5.3.18.) If this message appears, open and close the top cover and control panel. The message may disappear if opening/closing the top cover or control panel removes the error. If the error persists, the "MACHINE ERROR <u>X</u> <u>X</u> " will appear instead of this message.
SCANNER ERROR	In the scanning compensation data list printed by the maintenance-mode function code 05 (refer to CHAPTER 5, Subsection 5.3.2), fifty percent or more of the white level data is faulty. (This message may appear only in the maintenance mode)

If only an alarm beep is heard without any message on the LCD when the equipment is turned on, then the ROM or RAM will be defective.

[2] Error codes shown in the "MACHINE ERROR X X " message

If the LCD shows the "PLS OPEN COVER" message, you can display the detailed error code following the MACHINE ERROR, by using the maintenance-mode function code 82 described in CHAPTER 5, Section 5.3.18.

NOTE: When checking a PCB as instructed in the "Check:" column, check its harness also.

NOTE: To check sensors, use the maintenance-mode function code 32 described in CHAPTER 5, Section 5.3.9 (that is, press the 3 and 2 keys in the maintenance mode).

Error Code (Hex)	Error factor	Check:
25	Ink cartridges had already been loaded when the power was first applied.	Reload ink cartridges, referring to the Owner's Manual.
26	The black ink has run out.	<ul style="list-style-type: none"> • Ink cartridges • Cartridge PCB • Head flat cables • Main PCB • Ink empty sensor
27	The yellow ink has run out.	
28	The cyan ink has run out.	
29	The magenta ink has run out.	
30	The carriage cannot travel to the right or left.	<ul style="list-style-type: none"> • Carriage ASSY • Encoder strip (Any stains or scratches? Hooked correctly?) • Carriage motor • Main PCB • Power supply PCB • Purge unit • Main chassis
31	After driven by the specified number of pulses, the carriage does not stop (since it cannot detect the left end of the travel).	
33	During carriage travel except printing operation, the carriage suddenly stops or the travel speed decreases abnormally.	
35	The carriage stops during low-speed travel.	
3C	During printing operation, the carriage travel speed decreases abnormally.	
41	The head drive voltage has not been turned from Low to High within the specified time.	<ul style="list-style-type: none"> • Carriage ASSY • Main PCB • Print head unit • Power supply PCB
42	The head drive voltage has not been turned from High to Low within the specified time.	
43	Head thermister broken.	<ul style="list-style-type: none"> • Print head unit • Carriage ASSY • Main PCB
44	Head thermister short-circuited or error in its related parameters stored in the EEPROM of the main PCB	
45	Flushing operation abnormally ended. (The head temperature has arisen abnormally.)	<ul style="list-style-type: none"> • Print head unit

Error Code (Hex)	Error factor	Check:
46	The number of performed purge sequences has reached the limit.	<ul style="list-style-type: none"> • Ink absorber box • Main PCB
47	Head parameters stored in the EEPROM are invalid. (This code may appear only in the maintenance mode.)	<ul style="list-style-type: none"> • Print head unit • Main PCB • Power supply PCB
4D	Error in the head drive voltage parameter stored in the EEPROM but not accessible at the user site. (This code may appear only in the maintenance mode.)	<ul style="list-style-type: none"> • Main PCB
4E	Out of the allowable range of the head drive voltage designed for individual print head properties. (This code may appear only in the maintenance mode.)	<ul style="list-style-type: none"> • Main PCB • Print head unit
50	The purge cam HP switch does not come ON even after the purge cam has been driven by the specified number of pulses.	<ul style="list-style-type: none"> • Purge unit • Purge-related gears on the main chassis (Purge bevel gear A, ASF/purge idle gear, and ASF-purge switching gear 23) • Main chassis • Paper feed motor • Main PCB
51	The purge cam HP switch does not go OFF even after the purge cam has been driven by the specified number of pulses.	
52	The pump switching cam HP switch does not come ON even after the switching cam has been driven by the specified number of pulses.	
53	The pump switching cam HP switch does not go OFF even after the switching cam has been driven by the specified number of pulses.	
7D	Any of the ink dot counters has counted up to the specified number of dots, meaning the end of the head service life.	<ul style="list-style-type: none"> • Print head unit • Ink absorber box
7E	No head parameters stored in the EEPROM. (This code may appear only in the maintenance mode.)	<ul style="list-style-type: none"> • Print head unit • Main PCB
7F	Print engine error.	<ul style="list-style-type: none"> • Main PCB
80	At the start of recording operation, it is detected that paper is smaller than A4 size in length or width.	<ul style="list-style-type: none"> • Paper width sensor • Paper size
83	Recording paper jam. (At the retry of paper pulling-in operation, the registration sensor is not OFF.)	<ul style="list-style-type: none"> • Registration sensor actuator • Main PCB

Error Code (Hex)	Error factor	Check:
84	Recording paper jam. (The paper width sensor and/or registration sensor has detected a paper jam.)	<ul style="list-style-type: none"> • Paper width sensor actuator • Registration sensor actuator • Main PCB
88	Recording paper jam. (Even after paper pulling-in operation, the registration sensor is still OFF.)	
A1	Top cover or control panel opened.	<ul style="list-style-type: none"> • Cover/panel open sensor actuator • Main PCB • Top cover and control panel
A2	Document too long to scan.	<ul style="list-style-type: none"> • Document front sensor actuator • Document rear sensor actuator • Control panel PCB • Document sensor PCB • Document feed roller • Scanner motor • Main PCB
A3	Document not detected by the document rear sensor.	
A4	50% or more faulty of white level data.	<ul style="list-style-type: none"> • CIS unit • Main PCB
A7	One-line feeding timeout.	
A8	One-line scanning timeout.	
AC	Less than 50% faulty of white level data.	<ul style="list-style-type: none"> • CIS unit • Main PCB
B9	Light emission intensity error of the LED array (Exceeding the upper limit).	<ul style="list-style-type: none"> • CIS unit • Main PCB
BB	White level data value too low.	<ul style="list-style-type: none"> • CIS unit • Main PCB • Document pressure bar (any stains?)

Error Code (Hex)	Error factor	Check:
BD	Black level data value too high.	<ul style="list-style-type: none"> • CIS unit • Main PCB
D*	Modem error.	<ul style="list-style-type: none"> • Main PCB
E4	Out of recording paper.	<ul style="list-style-type: none"> • ASF • Registration sensor actuator • Document feed roller • Main PCB
E6	Write error in EEPROM.	<ul style="list-style-type: none"> • Main PCB
E8	Data scanning error during transmission.	<ul style="list-style-type: none"> • CIS unit • Main PCB
EA	Document removed at phase B.	
F3 F5	Internal software error.	<ul style="list-style-type: none"> • Replace the main PCB if this error occurs frequently.
F6	PC interface error.	<ul style="list-style-type: none"> • Interface cable • Main PCB
FF	Memory management error.	<ul style="list-style-type: none"> • Replace the main PCB if this error occurs frequently.

6.1.2 Communications Errors

If a communications error occurs, the facsimile equipment

- ① emits an audible alarm (intermittent beeping) for approximately 4 seconds,
- ② displays the corresponding error message, and
- ③ prints out the transmission verification report if the equipment is in sending operation.

■ Definition of Error Codes on the Communications List

(1) Calling

Code 1	Code 2	Causes
10	08	Wrong number called.
11	01	No dial tone detected before start of dialing.
11	02	Busy tone detected before dialing.
11	03	2nd dial tone not detected.
11	05	No loop current detected.*
11	06	Busy tone detected after dialing or called.
11	07	No response from the remote station in sending.
11	10	No tone detected after dialing.
17	07	No response from the calling station in receiving.

*Available in German versions only.

(2) Command reception

Code 1	Code 2	Causes
20	01	Unable to detect a flag field.
20	02	Carrier was OFF for 200 ms or longer.
20	03	Abort detected ("1" in succession for 7 bits or more).
20	04	Overrun detected.
20	05	A frame for 3 seconds or more received.
20	06	CRC error in answerback.
20	07	Undefined command received.
20	08	Invalid command received.
20	09	Command ignored once for document setting or for dumping-out at turn-around transmission.
20	0A	T5 time-out error
20	0B	CRP received.
20	0C	EOR and NULL received.

(3) Compatibility [checking the NSF and DIS]

Code 1	Code 2	Causes
32	01	Remote terminal only with V.29 capability in 2400 or 4800 bps transmission.
32	02	Remote terminal not ready for polling.
32	10	Remote terminal not equipped with password function or its password switch OFF.
32	11	Remote terminal not equipped with or not ready for confidential mailbox function.
32	12	Remote terminal not equipped with or not ready for relay broadcasting function.
32	13	No confidential mail in the remote terminal.
32	14	The available memory space of the remote terminal is less than that required for reception of the confidential or relay broadcasting instruction.
32	18	Remote terminal not equipped with color function.

(4) Instructions received from the remote terminal [checking the NSC, DTC, NSS, and DCS]

Code 1	Code 2	Causes
40	02	Illegal coding system requested.
40	03	Illegal recording width requested.
40	05	ECM requested although not allowed.
40	06	Polled while not ready.
40	07	No document to send when polled.
40	10	Nation code or manufacturer code not coincident.
40	13	Polled by any other manufacturers' terminal while waiting for secure polling.
40	17	Invalid resolution selected.
40	20	Invalid full-color mode requested.

(5) Command reception [checking the NSF and DIS after transmission of NSS and DCS]

Code 1	Code 2	Causes
50	01	Vertical resolution capability changed after compensation of background color.

(6) ID checking

Code 1	Code 2	Causes
63	01	Password plus "lower 4 digits of telephone number" not coincident.
63	02	Password not coincident.
63	03	Polling ID not coincident.

(7) DCN reception

Code 1	Code 2	Causes
74		DCN received.

(8) TCF transmission/reception

Code 1	Code 2	Causes
80	01	Fallback impossible.

(9) Signal isolation

Code 1	Code 2	Causes
90	01	Unable to detect video signals and commands within 6 seconds after CFR is transmitted.
90	02	Received PPS containing invalid page count or block count.

(10) Video signal reception

Code 1	Code 2	Causes
A0	03	Error correction sequence not terminated even at the final transmission speed for fallback.
A0	11	Receive buffer empty. (5-second time-out)
A0	12	Receive buffer full during operation except receiving into memory.
A0	13	Decoding error continued on 500 lines.
A0	14	Decoding error continued for 10 seconds.
A0	15	Time-out: 5 seconds or more for one-line transmission.
A0	16	RTC not found and carrier OFF signal detected for 6 seconds.
A0	17	RTC found but no command detected for 60 seconds.
A0	18	Receive buffer full during receiving into memory.
A0	19	No video data to be sent
A0	20	Unable to continue to receive color FAX (Remaining ink insufficient)
A8	01	RTN, PIN, or ERR received at the calling terminal.*
A9	01	RTN, PIN, or ERR received at the called terminal.*

* Available in German versions only

(11) General communications-related

Code 1	Code 2	Causes
B0	02	Unable to receive the next-page data.
B0	03	Unable to receive polling even during turn-around transmission due to call reservation.
B0	04	PC interface error.

(12) Maintenance mode

Code 1	Code 2	Causes
E0	01	Failed to detect 1300 Hz signal in burn-in operation.
E0	02	Failed to detect PB signals in burn-in operation.

(13) Equipment error

Code 1	Code 2	Causes
FF	<u>X</u> <u>X</u>	Equipment error (For <u>X</u> <u>X</u> , refer to Subsection 6.1.1 [2].)

6.2 TROUBLESHOOTING

6.2.1 Introduction

This section gives the service personnel some of the troubleshooting procedures to be followed if an error or malfunction occurs with the facsimile equipment. It is impossible to anticipate all of the possible problems which may occur in future and determine the troubleshooting procedures, so this section covers some sample problems. However, those samples will help service personnel pinpoint and repair other defective elements if he/she analyzes and examines them well.

6.2.2 Precautions

Be sure to observe the following to prevent the secondary troubles from happening:

- (1) Always unplug the AC power cord from the outlet when removing the covers and PCBs, adjusting the mechanisms, or conducting continuity testing with a circuit tester.
- (2) When disconnecting the connectors, do not pull the lead wires but hold the connector housings.
- (3)
 - Before handling the PCBs, touch a metal portion of the machine to discharge static electricity charged in your body.
 - When repairing the PCBs, handle them with extra care.

After repairing the defective section, be sure to check again if the repaired section works correctly. Also record the troubleshooting procedure so that it would be of use for future trouble occurrence.

6.2.3 Checking prior to Troubleshooting

Prior to proceeding to the troubleshooting procedures given in Subsection 6.2.4, make the following initial checks:

Environmental conditions

Check that:

- (1) The machine is placed on a flat, firm surface.
- (2) The machine is used in a clean environment at or near normal room temperature (10°C to 35°C) with normal relative humidity (20 to 80%).
- (3) The machine is not exposed to direct sunlight or harmful gases.

Power requirements

Check that:

- (1) The power supply specified on the rating plate located on the bottom of the machine is used. The supply voltage stays within the rating $\pm 10\%$.
- (2) Each voltage level on AC input lines and DC lines is correct.
- (3) All cables and harnesses are firmly connected.
- (4) None of the fuses are blown.

Recording paper

Check that:

- (1) A recommended type of recording paper is used.
- (2) The recording paper is not dampened.

Ink cartridges

- (1) Check that all of four ink cartridges are loaded.

Print head

- (1) Check that the print head is installed on the carriage correctly. (Check the dimple contact between the print head PCB and the carriage PCB.)
- (2) Repeat the head purging operation several times.
- (3) Clean the print surface of the print head unit. (Refer to page 6-23.)

6.2.4 Troubleshooting Procedures

[1] Control panel related

Trouble	Check:
(1) LCD shows nothing.	<ul style="list-style-type: none"> • Panel-main harness • Control panel PCB • Power supply PCB • Main PCB
(2) Control panel inoperative.	<ul style="list-style-type: none"> • Panel-main harness • Control panel PCB • FPC key • Main PCB

[2] Telephone related

Trouble	Check:
(1) No phone call can be made.	<ul style="list-style-type: none"> • FPC key • Control panel PCB • NCU PCB • Main PCB
(2) Speed dialing or one-touch dialing will not work.	<ul style="list-style-type: none"> • Ordinary dialing function (other than the speed and one-touch dialing) <p>If it works normally, check the main PCB; if not, refer to item (1) above.</p>
(3) Speaker silent during on-hook dialing.	<ul style="list-style-type: none"> • Ordinary dialing function (Pick up the handset and press the numerical keys.) <p>If it works normally, proceed to the following checks; if not, refer to item (1) above.</p>
(4) Dial does not switch between tone and pulse.	<ul style="list-style-type: none"> • Main PCB
(5) Telephone does not ring.	<ul style="list-style-type: none"> • Ringer • NCU PCB • Main PCB

[3] Communications related

Trouble	Check:
(1) No tone is transmitted.	<ul style="list-style-type: none"> • Main PCB • NCU PCB

[4] Paper/document feeding related

Trouble	Check:
(1) Neither "COPY: PRESS COPY" nor "FAX: NO. & START" message appears although documents are set.	<ul style="list-style-type: none"> • Sensors by using the maintenance-mode function code 32. (Refer to CHAPTER 5, Subsection 5.3.9.) • Document front sensor actuator and document rear sensor actuator <ul style="list-style-type: none"> • Main PCB
(2) Document not fed.	<ul style="list-style-type: none"> • ADF and its related sections • Scanner motor and its harness • Document feed rollers and their related gears • Main PCB
(3) Document double feeding	<ul style="list-style-type: none"> • ADF parts
(4) Document jam	<ul style="list-style-type: none"> • Scanner motor
(5) Recording paper not fed.	<ul style="list-style-type: none"> • ADF-related gears • Main PCB
(6) Recording paper jam	<ul style="list-style-type: none"> • Paper feeding mechanism • Eccentric bushing R and L (Alignment with markings made on the main chassis)



[5] Print-image related

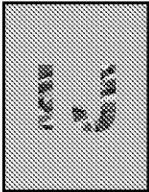
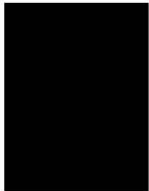

If the received or sent image has any problem, first make a copy with the facsimile equipment.

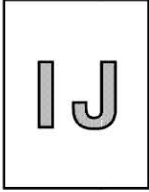
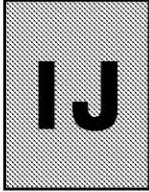
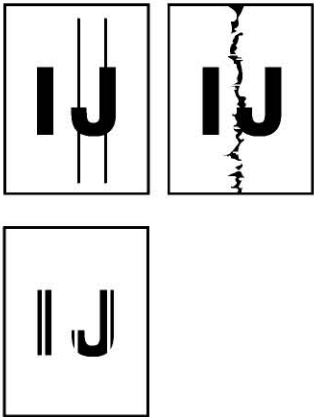
If the copied image is normal, the problem may be due to the remote terminal; if it is abnormal, proceed to the following checks:

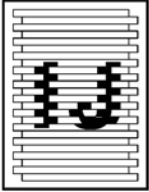
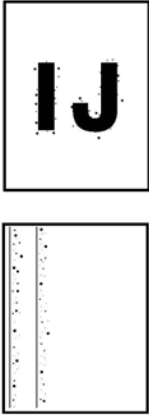
Trouble	Action to be taken
<p>(1) Completely blank</p> 	<p><u>At the scanner</u></p> <p>Check the following components:</p> <ul style="list-style-type: none"> - CIS harness - Main PCB - CIS unit <p><u>At the printer</u></p> <ul style="list-style-type: none"> • Check the ink cartridges. If any cartridges have run out of ink, replace them. • Check the dimple contact between each of the print head PCB and the mating carriage PCB. Clean it if contaminated. (If the problem persists, replace the carriage ASSY.) • Check the connection of the head flat cables on the main PCB. (If either of those cables is broken or damaged, replace it.) • Replace the main PCB. • Clean the head caps and wiper of the purge unit with a Rubycel stick. For the cleaning procedure, refer to "Cleaning the purge unit" given on page 6-23.
<p>(2) Random color</p> 	<p><u>At the scanner</u></p> <p>Check the following components:</p> <ul style="list-style-type: none"> - CIS harness - CIS unit - Main PCB <p><u>At the printer</u></p> <p>Check the following components:</p> <ul style="list-style-type: none"> - Print head unit - Main PCB - Carriage ASSY
<p>(3) All black</p> 	<p><u>At the scanner</u></p> <p>Check the following components:</p> <ul style="list-style-type: none"> - CIS harness - CIS unit - Main PCB <p><u>At the printer</u></p> <p>Check the following components:</p> <ul style="list-style-type: none"> - Print head unit - Main PCB - Carriage ASSY

Trouble	Action to be taken
<p>(4) Light</p> 	<p><u>At the scanner</u></p> <p>Check the following components:</p> <ul style="list-style-type: none"> - CIS unit - Main PCB <p><u>At the printer</u></p> <p>Check the following components:</p> <ul style="list-style-type: none"> - Ink cartridges - Print head unit - Main PCB - Power supply PCB - Print head parameters (to be installed to the main PCB from the connected PC. Refer to CHAPTER 2, Section 2.2.)
<p>(5) Dark</p> 	<p><u>At the scanner</u></p> <p>Check the following components:</p> <ul style="list-style-type: none"> - CIS unit - Main PCB <p><u>At the printer side</u></p> <ul style="list-style-type: none"> • For each of the four ink-jet units, perform the head purging operation several times to remove dust or air bubbles from its nozzles. If the problem persists, replace the print head unit. • Check the paper feed-related rollers. • Replace the main PCB and power supply PCB.
<p>(6) Black or blurred vertical stripes</p> 	<p><u>At the scanner</u></p> <p>Check the following components:</p> <ul style="list-style-type: none"> - CIS unit <p><u>At the printer side</u></p> <ul style="list-style-type: none"> • Check whether paper is in abnormal contact with any other components during ejecting. • Check the encoder strip for stains or scratches. (If the encoder strip is not hooked properly, correct it.)

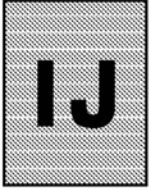
Trouble	Action to be taken
<p>(7) Print edges not aligned</p> 	<p><u>At the printer</u></p> <ul style="list-style-type: none"> • Check the alignment of vertical print lines by using the maintenance-mode function code 65. (Refer to CHAPTER 5, Subsection 5.3.13). • Check the print head unit. • Check the encoder strip for stains or scratches. (If the encoder strip is not hooked properly, correct it.)
<p>(8) Ink splash</p> 	<p><u>At the printer</u></p> <ul style="list-style-type: none"> • For each of the four ink-jet units, perform the head purging operation several times to remove dust or air bubbles from its nozzles. • Check the ink cartridges. Any of them has run out of ink or the ink viscosity has been increased, so replace it. • Replace the print head unit. • Replace the main PCB. • Replace the power supply PCB. • Check that the eccentric bushings R and L are aligned with markings made on the main chassis to adjust the head-platen gap.
<p>(9) Random missing dots</p> 	<p><u>At the printer</u></p> <ul style="list-style-type: none"> • For each of the four ink-jet units, perform the head purging operation several times to remove dust or air bubbles from its nozzles. • Check the ink cartridges. If any cartridges have run out of ink, replace them. • Check the dimple contact between each of the print head PCB and the mating carriage PCB. Clean it if contaminated. • Replace the print head unit. (If the problem persists, replace the carriage ASSY.) • Check the connection of the head flat cables on the main PCB. (If either of those cables is broken or damaged, replace it.) • Replace the main PCB. • Clean the head caps and wiper of the purge unit with a Rubycel stick. For the cleaning procedure, refer to "Cleaning the purge unit" given on page 6-23.

Trouble	Action to be taken
<p>(10) White horizontal streaks</p> 	<ul style="list-style-type: none"> • For each of the four ink-jet units, perform the head purging operation several times to remove dust or air bubbles from its nozzles. • Replace the print head unit. • Check the paper feed-related rollers. • Clean the head caps and wiper of the purge unit with a Rubycel stick. For the cleaning procedure, refer to "Cleaning the purge unit" given on the next page.
<p>(11) Stained leading edge of recording paper</p> 	<p><u>At the printer</u></p> <ul style="list-style-type: none"> • Clean the nozzle ends of the ink-jet units. • Check that the eccentric bushings R and L are aligned with markings made on the main chassis to adjust the head-platen gap.

[6] PC-driven printing

Trouble	Action to be taken
<p>(1) PC-driven printing is impossible.</p>	<ul style="list-style-type: none"> • Interface with the host computer • PC interface cable • Main PCB • Centronics interface • USB interface

Cleaning the purge unit

- (1) Unplug the machine's power cord from the wall socket.
- (2) Plug the power cord again. When you hear the carriage moving out of the home position for initialization, then unplug the power cord again. The carriage will stop at the middle of the travel.
- (3) Open the top cover.
- (4) Clean the two head caps and wiper of the purge unit with a "Rubycel" stick that is a head cleaner stick provided as a spare part.

NOTE: Do not use a cotton swab that may leave lint on the cleaned sections. Lint left on the purge unit will affect the print performance.

NOTE: Use a new Rubycel stick and do not use the used one for any other purge units.

NOTE: During the cleaning jobs, take care not to touch the head caps or wiper directly by hand or scratch their surfaces. Do not remove them from the head cap holder.

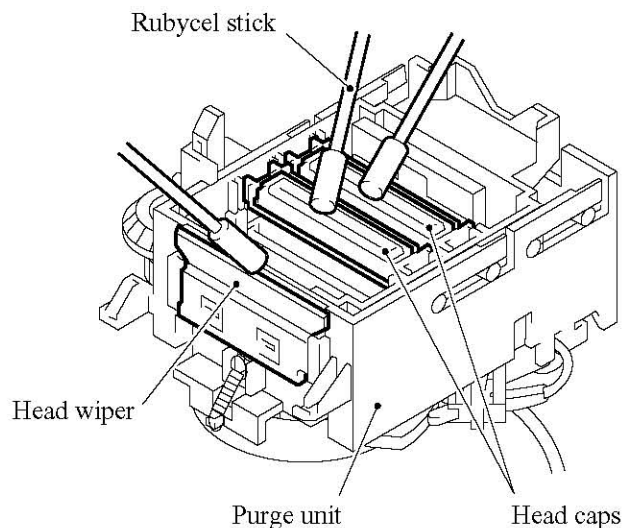

Cleaning the print head unit

- (1) Remove the print head unit from the carriage. (Refer to CHAPTER 4, Section 4.1.1.)
- (2) Soak a Rubycel stick in "Glycerol cleaner."
- (3) Clean the printing surface of the print head unit by rolling the Rubycel stick lightly on the printing surface.

NOTE: Do not use a cotton swab that may leave lint on the cleaned sections. Lint left on the purge unit will affect the print performance.

NOTE: Use a new Rubycel stick and do not use the used one for any other print heads.

NOTE: During the cleaning jobs, take care not to scratch the surface of the print head.

EEPROM CUSTOMIZING CODES

This function allows you to customize the EEPROM according to language, function settings, and firmware switch settings.

■ Operating Procedure

← Within 2 seconds →

- (1) Press the **Menu**, *****, **2**, **8**, **6**, and **4** keys in this order to make the facsimile equipment enter the maintenance mode.

The equipment beeps for approx. one second and displays "■■ MAINTENANCE ■■" on the LCD.

- (2) Press the **7** and **4** keys in this order in the initial stage of the maintenance mode.

The current customizing code (e.g., B001 in the case of MFC3100C U.S.A. versions) appears.

- (3) Enter the desired customizing code (e.g., 2002 in the case of MFC3100C Canadian version).

The newly entered code appears.

NOTE: If a wrong 4-digit code is entered, the equipment will malfunction.

- (4) Press the **Black Fax Start** key.

The equipment saves the setting and returns to the initial stage of the maintenance mode.

If you press the **Stop** key or no keys are pressed for one minute in the above procedure, the equipment stops the procedure and returns to the initial stage of the maintenance mode.

■ EEPROM Customizing Codes List

(1) MFC3100C

Versions	Model
	MFC3100C
U.S.A.	B001 *
CANADA	2002
AUSTRALIA	2006
ASIA (SINGAPORE, HONG KONG)	2040
NEW ZEALAND	2027

(2) MFC580

Versions	Model
	MFC580
GERMANY	2003
U.K.	2004
FRANCE	2005
BELGIUM	2008
NETHERLANDS	2009
SWITZERLAND	2010
IRELAND	2004
DENMARK	2057
AUSTRIA	2003
SPAIN	2015
ITALY	2016
SOUTH AFRICA	2004
EURO GENERIC	2054
PAN-NORDIC	2057

(3) FAX1800C

Versions	Model
	FAX1800C
U.S.A.	B001 *

* To enter letters "A" through "F," press the 1 through 6 keys while holding down the # key, respectively.

WSW No.	Function	Reference Page
WSW01	Dial pulse setting	2
WSW02	Tone signal setting	3
WSW03	PABX mode setting	4
WSW04	TRANSFER facility setting	5
WSW05	1st dial tone and busy tone detection	6
WSW06	Pause key setting and 2nd dial tone detection	8
WSW07	Dial tone setting 1	10
WSW08	Dial tone setting 2	11
WSW09	Protocol definition 1	12
WSW10	Protocol definition 2	13
WSW11	Busy tone setting	14
WSW12	Signal detection condition setting	15
WSW13	Modem setting	16
WSW14	AUTO ANS facility setting	17
WSW15	REDIAL facility setting	18
WSW16	Function setting 1	19
WSW17	Function setting 2	20
WSW18	Function setting 3	21
WSW19	Transmission speed setting	22
WSW20	Overseas communications mode setting	23
WSW21	TAD setting 1	24
WSW22	ECM and copy resolution setting	24
WSW23	Communications setting	25
WSW24	TAD setting 2	26
WSW25	TAD setting 3	26
WSW26	Function setting 4	27
WSW27	Function setting 5	28
WSW28	Function setting 6	29
WSW29	Function setting 7	30
WSW30	Not used.	30
WSW31	Function setting 9	31
WSW32	Function setting 10	32
WSW33	Function setting 11	33
WSW34	Function setting 12	34
WSW35	Not used.	34
WSW36	Function setting 14	35
WSW37	Function setting 15	36
WSW38	Not used.	36
WSW39	Not used.	36
WSW40	Not used.	36
WSW41	Not used.	36
WSW42	Function setting 20	37
WSW43	Function setting 21	37
WSW44	Not used.	37
WSW45	Not used.	37
WSW46	Monitor of power ON/OFF state and parallel port kept at high	38
WSW47	Paper handling for a feed error and delay of FAX line disconnection	39
WSW48	Not used.	39
WSW49	Not used.	39
WSW50	Not used.	39

WSW01 (Dial pulse setting)

Selector No.	Function	Setting and Specifications
1 2	Dial pulse generation mode	No. 1 2 0 0 : N 0 1 : N+1 1 0 : 10-N 1 1 : N
3 4	Break time length in pulse dialing	No. 3 4 0 0 : 60 ms 0 1 : 67 ms 1 0 : 40 ms (for 16 PPS) 1 1 : 64 ms (at 106-ms intervals)
5 6	Inter-digit pause	No. 5 6 0 0 : 800 ms 0 1 : 850 ms 1 0 : 950 ms 1 1 : 600 ms
7	Switching between pulse (DP) and tone (PB) dialing, by the function switch	0: Yes 1: No
8	Default dialing mode, pulse (DP) or tone (PB) dialing	0: PB 1: DP

- Selectors 1 and 2: Dial pulse generation mode**

These selectors set the number of pulses to be generated in pulse dialing.

N: Dialing "N" generates "N" pulses. (Dialing "0" generates 10 pulses.)

N + 1: Dialing "N" generates "N + 1" pulses.

10 - N: Dialing "N" generates "10 - N" pulses.

- Selectors 3 and 4: Break time length in pulse dialing**

These selectors set the break time length in pulse dialing.

(Example: If "1," "2," and "3" are dialed when N is set by selectors 1 and 2.)

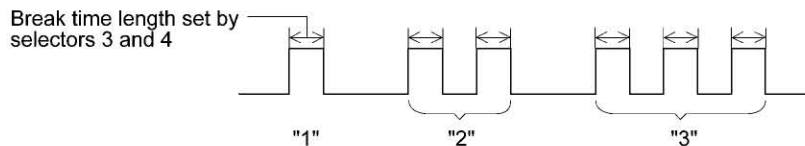

- Selectors 5 and 6: Inter-digit pause**

These selectors set the inter-digit pause in pulse dialing.

(Example: If "1," "2," and "3" are dialed when N is set by selectors 1 and 2.)

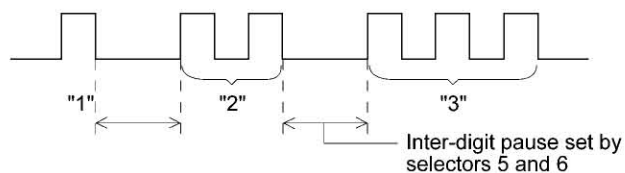

- **Selector 7: Switching between pulse (DP) and tone (PB) dialing, by the function switch**
This selector determines whether or not the dialing mode may be switched between the pulse (DP) and tone (PB) dialing by using the function switch.
- **Selector 8: Default dialing mode, pulse (DP) or tone (PB) dialing**
This selector sets the default dialing mode (pulse dialing or tone dialing) which may be changed by the function switch. If the user switches it with the function switch when selector 7 is set to "0," the setting specified by this selector will also be switched automatically.

WSW02 (Tone signal setting)

Selector No.	Function	Setting and Specifications
1 2	Tone signal transmission time length	No. 1 2 0 0 : 70 ms 0 1 : 80 ms 1 0 : 90 ms 1 1 : 100 ms
3 4	Min. pause in tone dialing	No. 3 4 0 0 : 70 ms 0 1 : 80 ms 1 0 : 90 ms 1 1 : 140 ms
5 8	Attenuator for pseudo ring backtone to the line (selectable in the range of 0-15 dB)	0: 0 dB 1: 8 dB 0: 0 dB 1: 4 dB 0: 0 dB 1: 2 dB 0: 0 dB 1: 1 dB

- **Selectors 1 through 4: Tone signal transmission time length and Min. pause in tone dialing**
These selectors set the tone signal transmission time length and minimum pause in tone dialing. (Example: If "1," "2," "3," "4," and "5" are dialed.)

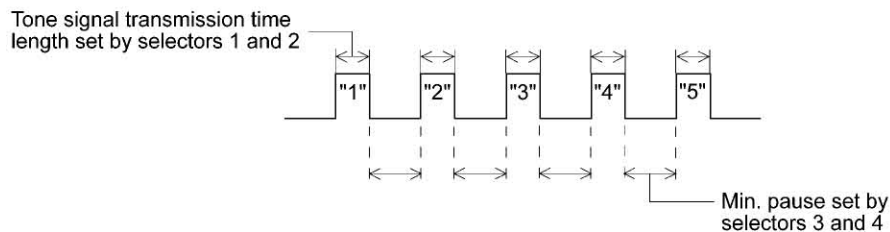

- **Selectors 5 through 8: Attenuator for pseudo ring backtone to the line**
These selectors are used to adjust the sound level of beep generated as a ring backtone in the F/T mode or as a signal during remote control operation or at the start of ICM recording.
Setting two or more selectors to "1" produces addition of attenuation assigned to each selector.

WSW03 (PABX* mode setting)

Selector No.	Function	Setting and Specifications
1	CNG detection when sharing a modular wall socket with a telephone	0: A 1: B
2 4	Min. detection time length of PABX* dial tone, required for starting dialing	No. 2 3 4 0 0 0 : 50 ms 0 0 1 : 210 ms 0 1 0 : 500 ms 0 1 1 : 800 ms 1 0 0 : 900 ms 1 0 1 : 1.5 sec. 1 1 0 : 2.0 sec. 1 1 1 : 2.5 sec.
5	CNG detection when sharing a modular wall socket with a telephone	0: A 1: B
6 7	Dial tone detection in PABX*	No. 6 7 0 0 : No detection (3.5 sec. WAIT) 0 1 : No detection (5 sec. WAIT) 1 0 : No detection (7 sec. WAIT) 1 1 : Detection (Frequency only)
8	Not used.	

* PABX: Private automatic branch exchange

NOTE: Selectors 2 through 4, 6 and 7 are not applicable where no PABX is installed.

● **Selectors 1 and 5: CNG detection when sharing a modular wall socket with a telephone**

These selectors determine whether or not the equipment detects a CNG signal when a line is connected to a telephone sharing a modular wall socket with the equipment. Upon detection of CNG signals by the number of cycles specified by these selectors, the equipment interprets CNG as an effective signal and then starts FAX reception.

Selector		Cycle
No. 1	No. 5	
0 (A)	0 (A)	0.5 cycle
0 (A)	1 (B)	1.0 cycle
1 (B)	0 (A)	1.5 cycles
1 (B)	1 (B)	2.0 cycles

● **Selectors 2 through 4: Min. detection time length of PABX dial tone, required for starting dialing**

Upon detection of the PABX dial tone for the time length set by these selectors, the equipment starts dialing.

These selectors are effective only when both selectors 6 and 7 are set to "1" (Detection).

- **Selectors 6 and 7: Dial tone detection in PABX**

These selectors activate or deactivate the dial tone detection function which detects a dial tone when a line is connected to the PABX.

Setting both of these selectors to "1" activates the dial tone detection function so that the equipment starts dialing upon detection of a dial tone when a line is connected.

Other setting combinations deactivate the dial tone detection function so that the equipment starts dialing after the specified WAIT (3.5, 5.0, or 7.0 sec.) without detection of a dial tone when a line is connected.

WSW04 (TRANSFER facility setting)

Selector No.	Function	Setting and Specifications
1	Earth function in transfer facility	0: Provided 1: Not provided
2 4	Not used.	
5 6	Earth time length for earth function	No. 5 6 0 0 : 200 ms 0 1 : 300 ms 1 0 : 500 ms 1 1 : 700 ms
7 8	Break time length for flash function	No. 7 8 0 0 : 80 ms 0 1 : 110 ms 1 0 : 250 ms 1 1 : 500 ms

NOTE: Selectors 1 and 5 through 8 are not applicable in those countries where no transfer facility is supported.

- **Selector 1: Earth function in transfer facility**

This selector determines whether or not the earth function is added to the transfer setting menu to be accessed by the function switch.

- **Selectors 5 and 6: Earth time length for earth function**

These selectors set the short-circuiting time length of the telephone line (La or Lb) to ground.

This setting is effective only when the earth function is selected for the R key by using the function switch.

- **Selectors 7 and 8: Break time length for flash function**

These selectors set the break time length.

This setting is effective only when the flash function is selected for the Speed Dial key by using the function switch.

WSW05 (1st dial tone and busy tone detection)

Selector No.	Function	Setting and Specifications
1 3	1st dial tone detection	No. 1 2 3 0 0 0 : 3.5 sec. WAIT 0 0 1 : 7.0 sec. WAIT 0 1 0 : 10.5 sec. WAIT 0 1 1 : 14.0 sec. WAIT 1 0 0 : 17.5 sec. WAIT 1 0 1 : 21.0 sec. WAIT 1 1 0 : 24.5 sec. WAIT 1 1 1 : Detection (Without WAIT)
4	Max. pause time allowable for remote ID code detection	0 : 2 seconds 1: 1 second
5 6	Busy tone detection in automatic sending mode	No. 5 6 0 0 : No detection 0 1 : Detection only after dialing 1 0 : No detection 1 1 : Detection before and after dialing
7	Busy tone detection in automatic receiving mode	0 : Yes 1: No
8	Not used.	

NOTE: Selectors 5 through 7 are not applicable in those countries where no busy tone detection is supported.

- **Selectors 1 through 3: 1st dial tone detection**

These selectors activate or deactivate the 1st dial tone detection function which detects the 1st dial tone issued from the PSTN when a line is connected to the PSTN.

Setting all of these selectors to "1" activates the dial tone detection function so that the equipment starts dialing upon detection of a dial tone when a line is connected. (However, in those countries which support no dial tone detection function, e.g., in the U.S.A., setting these selectors to "1" makes the equipment start dialing after a WAIT of 3.5 seconds.) For the detecting conditions of the 1st dial tone, refer to WSW07 and WSW08.

Other setting combinations deactivate the dial tone detection function so that the equipment starts dialing after the specified WAIT (3.5, 7.0, 10.5, 14.0, 17.5, 21.0, or 24.5 seconds) without detection of a dial tone when a line is connected to the PSTN.

- **Selector 4: Max. pause time allowable for remote ID code detection**

This selector sets the maximum pause time allowable for detecting the second digit of a remote ID code after detection of the first digit in remote reception.

If selector 4 is set to "0" (2 seconds), for instance, only a remote ID code whose second digit is detected within 2 seconds after detection of the first digit will become effective so as to activate the remote function.

- **Selectors 5 and 6: Busy tone detection in automatic sending mode**

These selectors determine whether or not the equipment automatically disconnects a line upon detection of a busy tone in automatic sending mode.

Setting selector 6 to "0" ignores a busy tone so that the equipment does not disconnect the line.

Setting selectors 5 and 6 to "0" and "1," respectively, makes the equipment detect a busy tone only after dialing and disconnect the line.

Setting both of selectors 5 and 6 to "1" makes the equipment detect a busy tone before and after dialing and then disconnect the line.

- **Selector 7: Busy tone detection in automatic receiving mode**

This selector determines whether or not the equipment automatically disconnects the line upon detection of a busy tone in automatic receiving mode.

WSW06 (Pause key setting and 2nd dial tone detection)

Selector No.	Function	Setting and Specifications
1 3	Pause key setting and 2nd dial tone detection	No.1 2 3 0 0 0 : No pause 0 0 1 : 3.5 sec. WAIT 0 1 0 : 7 sec. WAIT 0 1 1 : 10.5 sec. WAIT 1 0 0 : 14 sec. WAIT 1 1 0 : 2nd dial tone detection only in pulse dialing (DP) system 1 0 1 : } 2nd dial tone detection 1 1 1 : } both in DP and push-button (PB) dialing system
4 6	Detection of international tone	No.4 5 6 0 0 0 : 50 ms 0 0 1 : 210 ms 0 1 0 : 500 ms 0 1 1 : 800 ms 1 0 0 : 900 ms 1 0 1 : 1.5 sec. 1 1 0 : 2.0 sec. 1 1 1 : 2.5 sec.
7	No. of 2nd dial tone detection times	0: Once 1: Twice
8	2nd dial tone interrupt detecting time	0: 30 ms 1: 50 ms

NOTE: Selectors 4 through 8 are not applicable in those countries where no dial tone detection is supported, e.g., U.S.A.

- **Selectors 1 through 3: Pause key setting and 2nd dial tone detection**

Selectors			
1	2	3	
0	0	0	No WAIT is inserted even if the Pause key is pressed.
0	0	1	If you press the Pause key during dialing, the facsimile equipment will insert WAIT as defined in the above table. If the Pause key is pressed repeatedly, the equipment inserts the specified WAIT multiplied by the number of depressions. It applies also in hook-up dialing.
0	1	0	
0	1	1	
1	0	0	
1	0	1	When these selectors are set to "1, 0, 1": Each time you press the Pause key in dialing, the equipment will wait for the 2nd dial tone to be sent via the communications line regardless of pulse dialing or tone dialing. When these selectors are set to "1, 1, 0": If you press the Pause key in pulse dialing, the equipment will first wait for the 2nd dial tone to be sent via the communications line. After that, pressing the Pause key will cause the equipment to insert a WAIT of 3.5 seconds. In tone dialing, the equipment will insert a WAIT of 3.5 seconds. When these selectors are set to "1, 1, 1": If you press the Pause key, the equipment will first wait for the 2nd dial tone to be sent via the communications line regardless of pulse dialing or tone dialing. After that, pressing the Pause key will cause the equipment to insert a WAIT of 3.5 seconds. (In those countries where no dial tone detection function is supported, setting these selectors to "1, 0, 1," "1, 1, 0," or "1, 1, 1" inserts a WAIT of 3.5 seconds.)
1	1	0	
1	1	1	

- **Selectors 4 through 6: Detection of international tone**

Upon detection of the 2nd dial tone for the time length specified by these selectors, the equipment starts dialing.

This setting is effective only when the 2nd dial tone detection function is activated by selectors 1 through 3 (Setting 101, 110, or 111).

This function does not apply in those countries where no dial tone detection function is supported.

- **Selector 7: No. of 2nd dial tone detection times**

This selector sets the number of dial tone detection times required for starting dialing.

- **Selector 8: 2nd dial tone interrupt detecting time**

This selector sets the allowable time length of an interrupt which should not be interpreted as an interrupt in the 2nd tone dialing.

WSW07 (Dial tone setting 1)

Selector No.	Function	Setting and Specifications
1 2	Frequency band range	No. 1 2 0 0 : Narrows by 10 Hz 0 1 : Initial value 1 X : Widens by 10 Hz
3	Line current detection	0: No 1: Yes
4 6	2nd dial tone detection level (Z = 600 Ω)	No. 4 5 6 0 0 0 : -21 dBm 0 0 1 : -24 dBm 0 1 0 : -27 dBm 0 1 1 : -30 dBm 1 0 0 : -33 dBm 1 0 1 : -36 dBm 1 1 0 : -39 dBm 1 1 1 : -42 dBm
7	1st dial tone interrupt detecting time	0: 30 ms 1: 50 ms
8	Not used.	

NOTE: Selectors 1, 2, 4 through 7 are not applicable in those countries where no dial tone or line current detection is supported, e.g., U.S.A.

NOTE: Selector 3 is not applicable to those models having no loop current detection function.

- **Selectors 1 and 2: Frequency band range**

These selectors set the frequency band for the 1st dial tone and the busy tone (before dialing) to be detected.

This setting is effective only when selectors 1 through 3 of WSW05 are set to "1,1,1."

- **Selector 3: Line current detection**

This selector determines whether or not the equipment should detect a line current before starting dialing.

- **Selectors 4 through 6: 2nd dial tone detection level**

These selectors set the detection level of the 2nd dial tone.

- **Selector 7: 1st dial tone interrupt detecting time**

This selector sets the allowable time length of an interrupt which should not be interpreted as an interrupt in the 1st dial tone dialing.

WSW08 (Dial tone setting 2)

Selector No.	Function	Setting and Specifications
1 3	1st dial tone detection time length	No. 1 2 3 0 0 0 : 50 ms 0 0 1 : 210 ms 0 1 0 : 500 ms 0 1 1 : 800 ms 1 0 0 : 900 ms 1 0 1 : 1.5 sec. 1 1 0 : 2.0 sec. 1 1 1 : 2.5 sec.
4 5	Time-out length for 1st and 2nd dial tone detection	No. 4 5 0 0 : 10 sec. 0 1 : 20 sec. 1 0 : 15 sec. 1 1 : 30 sec.
6 8	Detection level of 1st dial tone and busy tone before dialing	No. 6 7 8 0 0 0 : -21 dBm 0 0 1 : -24 dBm 0 1 0 : -27 dBm 0 1 1 : -30 dBm 1 0 0 : -33 dBm 1 0 1 : -36 dBm 1 1 0 : -39 dBm 1 1 1 : -42 dBm

NOTE: The WSW08 is not applicable in those countries where no dial tone detection is supported, e.g., U.S.A.

- **Selectors 1 through 3: 1st dial tone detection time length**

Upon detection of the 1st dial tone for the time length set by these selectors, the equipment starts dialing.

This setting is effective only when selectors 1 through 3 of WSW05 are set to "1,1,1."

- **Selectors 4 and 5: Time-out length for 1st and 2nd dial tone detection**

These selectors set the time-out length for the 1st and 2nd dial tone detection so that the equipment waits dial tone input for the specified time length and disconnects itself from the line when no dial tone is inputted.

WSW09 (Protocol definition 1)

Selector No.	Function	Setting and Specifications	
1	Frame length selection	0: 256 octets 1: 64 octets	
2	Use of non-standard commands	0: Allowed 1: Prohibited	
3 4	No. of retries	No. 3 4 0 0 : 4 times 0 1 : 3 times 1 0 : 2 times 1 1 : 1 time	
5		T5 timer	0: 300 sec. 1: 60 sec.
6		T1 timer	0: 35 sec. 1: 40 sec.
7 8		Elapsed time for time-out control for no response from the called station in automatic sending mode	No. 7 8 0 0 : { 55 sec. (in U.S.A. and Canadian versions) 60 sec. (in other versions) 0 1 : 140 sec. 1 0 : 90 sec. 1 1 : 35 sec.

NOTE: Selectors 1 through 5 are not applicable in those models which do not support ECM.

- **Selector 1: Frame length selection**

Usually a single frame consists of 256 octets (1 octet = 8 bits). For communications lines with higher bit error rate, however, set selector 1 to "1" so that the facsimile equipment can divide a message into 64-octet frames.

Remarks: The error correction mode (ECM) is a facsimile transmission manner in which the equipment divides a message into frames for transmission so that if any data error occurs on the transmission line, the equipment retransmits only those frames containing the error data.

- **Selector 2: Use of non-standard commands**

If this selector is set to "0," the equipment may use non-standard commands (the machine's native-mode commands, e.g., NSF, NSC, and NSS) for communications. If it is set to "1," the equipment will use standard commands only.

- **Selectors 3 and 4: No. of retries**

These selectors set the number of retries in each specified modem transmission speed.

- **Selector 5: T5 timer**

This selector sets the time length for the T5 timer.

- **Selector 6: T1 timer**

This selector sets the time length for the T1 timer.

- **Selectors 7 and 8: Elapsed time for time-out control**

If the equipment receives no response (no G3 command) from the called terminal in automatic sending during the time set by these selectors, it disconnects the line.

WSW10 (Protocol definition 2)

Selector No.	Function	Setting and Specifications
1	Not used.	
2	Time length from transmission of the last dial digit to CML ON	0: 100 ms 1: 50 ms
3	Time length from CML ON to CNG transmission	0: 2 sec. 1: 4 sec.
4	Time length from CML ON to CED transmission (except for facsimile-to-telephone switching)	0: 0.5 sec. 1: 2 sec.
5 6	No. of training retries	No. 5 6 0 0 : 1 time 0 1 : 2 times 1 0 : 3 times 1 1 : 4 times
7	Encoding system (Compression)	MR 0: Allowed 1: Not allowed
8		MMR 0: Allowed 1: Not allowed

- **Selector 2: Time length from transmission of the last dial digit to CML ON**
This selector sets the time length from when the equipment transmits the last dial digit until the CML relay comes on.
- **Selector 3: Time length from CML ON to CNG transmission**
This selector sets the time length until the equipment transmits a CNG after it turns on the CML relay.
- **Selector 4: Time length from CML ON to CED transmission**
This selector sets the time length until the equipment transmits a CED after it turns on the CML relay. This setting does not apply to switching between facsimile and telephone.
- **Selectors 5 and 6: No. of training retries**
These selectors set the number of training retries to be repeated before automatic fallback.
- **Selectors 7 and 8: Encoding system (Compression)**
This selector determines whether or not use of the MR/MMR coding system will be allowed.

WSW11 (Busy tone setting)

U.S.A. and Canadian versions

Selector No.	Function	Setting and Specifications
1 2	Frequency band range	No. 1 2 0 0 : Narrows by 10 Hz 0 1 : Initial value 1 x : Widens by 10 Hz
3	Not used.	
4	ON/OFF time length ranges (More than one setting allowed)	1: 400-600/400-600 ms
5		1: 175-440/175-440 ms
6		1: 100-1000 ms/17-660 ms
7		1: 110-410/320-550 ms
8		1: 100-660/100-660 ms

Other versions

Selector No.	Function	Setting and Specifications
1 2	Frequency band range	No. 1 2 0 0 : Narrows by 10 Hz 0 1 : Initial value 1 x : Widens by 10 Hz
3	ON/OFF time length ranges (More than one setting allowed)	1: 250-750/250-750 ms
4		1: 400-600/400-600 ms
5		1: 175-440/175-440 ms
6		1: 100-1000 ms/17-660 ms
7		1: 110-410/320-550 ms
8	1: 100-660/100-660 ms	

NOTE: WSW11 is not applicable in those countries where no busy tone detection is supported.

NOTE: The setting of WSW11 is effective only when selectors 5 and 6 of WSW05 are set to "0, 1" or "1, 1" (Busy tone detection).

- **Selectors 1 and 2: Frequency band range**

These selectors set the frequency band for busy tone to be detected.

- **Selectors 4 through 8**
Selectors 3 through 8: ON/OFF time length ranges

These selectors set the ON and OFF time length ranges for busy tone to be detected. If more than one selector is set to "1," the ranges become wider. For example, if selectors 4 and 5 are set to "1," the ON and OFF time length ranges are from 175 to 600 ms.

WSW12 (Signal detection condition setting)

Selector No.	Function	Setting and Specifications
1 2	Min. OFF time length of calling signal (Ci)	No. 1 2 0 0 : 1500 ms 0 1 : 500 ms 1 0 : 700 ms 1 1 : 900 ms
3 4	Max. OFF time length of calling signal (Ci)	No. 3 4 0 0 : 6 sec. 0 1 : 7 sec. 1 0 : 9 sec. 1 1 : 11 sec.
5 6	Detecting time setting	No. 5 6 0 0 : 800 ms (1000 ms*) 0 1 : 200 ms 1 0 : 250 ms 1 1 : 150 ms
7 8	Not used.	

*1000 ms in Chinese versions.

- Selectors 1 through 4: Min. and max. OFF time length of calling signal (Ci)**

If the equipment detects the OFF state of calling signal (Ci) for a time length which is greater than the value set by selectors 1 and 2 and less than the value set by selectors 3 and 4, it interprets the Ci signal as OFF.

- Selectors 5 and 6: Detecting time setting**

These selectors set the time length required to make the equipment acknowledge itself to be called. That is, if the equipment continuously detects calling signals with the frequency set by selectors 1 through 4 of WSW14 during the time length set by these selectors 5 and 6, it acknowledges the call.

WSW13 (Modem setting)

Selector No.	Function	Setting and Specifications
1 2	Cable equalizer	No. 1 2 0 0 : 0 km 0 1 : 1.8 km 1 0 : 3.6 km 1 1 : 5.6 km
3 4	Reception level	No. 3 4 0 0 : -43 dBm 0 1 : -47 dBm 1 0 : -49 dBm 1 1 : -51 dBm
5 8	Modem attenuator	0: 0 dB 1: 8 dB 0: 0 dB 1: 4 dB 0: 0 dB 1: 2 dB 0: 0 dB 1: 1 dB

The modem should be adjusted according to the user's line conditions.

- **Selectors 1 and 2: Cable equalizer**

These selectors are used to improve the pass-band characteristics of analogue signals on a line. (Attenuation in the high-band frequency is greater than in the low-band frequency.)

Set these selectors according to the distance from the telephone switchboard to the facsimile equipment.

- **Selectors 3 and 4: Reception level**

These selectors set the optimum receive signal level.

- **Selectors 5 through 8: Modem attenuator**

These selectors are used to adjust the transmitting level of the modem when the reception level at the remote station is improper due to line loss. This function applies for G3 protocol signals.

Setting two or more selectors to "1" produces addition of attenuation assigned to each selector.

This setting will be limited if selector 8 of WSW23 is set to "0."

WSW14 (AUTO ANS facility setting)

Selector No.	Function	Setting and Specifications
1 2	Frequency band selection (Lower limit)	No. 1 2 0 0 : 13 Hz 0 1 : 15 Hz 1 0 : 23 Hz 1 1 : 20 Hz
3 4	Frequency band selection (Upper limit)	No. 3 4 0 0 : 30 Hz 0 1 : 55 Hz 1 X : 70 Hz
5 8	No. of rings in AUTO ANS mode	No. 5 6 7 8 0 0 0 0 : Fixed to once 0 0 0 1 : Fixed to 2 times 0 0 1 0 : Fixed to 3 times 0 0 1 1 : Fixed to 4 times 0 1 0 0 : 1 to 2 times 0 1 0 1 : 1 to 3 times 0 1 1 0 : 1 to 4 times 0 1 1 1 : 1 to 5 times 1 0 0 0 : 2 to 3 times 1 0 0 1 : 2 to 4 times 1 0 1 0 : 2 to 5 times 1 0 1 1 : 2 to 6 times 1 1 0 0 : 1 to 10 times 1 1 0 1 : 2 to 10 times 1 1 1 0 : 3 to 5 times 1 1 1 1 : 4 to 10 times

- **Selectors 1 through 4: Frequency band selection**

These selectors are used to select the frequency band of calling signals for activating the AUTO ANS facility.

In the French versions, if the user sets the PBX to OFF from the control panel, the setting made by selectors 1 and 2 will take no effect and the frequency's lower limit will be fixed to 32 Hz. (Even if the setting made by these selectors does not apply, it will be printed on the configuration list.)

- **Selectors 5 through 8: No. of rings in AUTO ANS mode**

These selectors set the number of rings to initiate the AUTO ANS facility.

WSW15 (REDIAL facility setting)

Selector No.	Function	Setting and Specifications
1 2	Selection of redial interval	No. 1 2 0 0 : 5 minutes 0 1 : 1 minute 1 0 : 2 minutes 1 1 : 3 minutes
3 6	No. of redialings	No. 3 4 5 6 0 0 0 0 : 16 times 0 0 0 1 : 1 times 0 0 1 0 : 2 times 0 0 1 1 : 3 times 1 1 1 1 : 15 times
7	Redialing for no response sent from the called terminal	0: Redialing 1: No redialing
8	Not used.	

- **Selectors 1 through 6: Selection of redial interval and No. of redialings**

The equipment redials by the number of times set by selectors 3 through 6 at intervals set by selectors 1 and 2.

- **Selector 7: Redialing for no response sent from the called terminal**

This selector determines whether or not the equipment redials if no G3 command response comes from the called station after dialing within the time length set by selectors 7 and 8 of WSW09.

WSW16 (Function setting 1)

Selector No.	Function	Setting and Specifications
1	Not used.	
2	ITU-T (CCITT) superfine recommendation	0: OFF 1: ON
3 6	Not used.	
7	Max. document length limitation	0: 400 cm 1: 90 cm
8	Stop key pressed during reception	0: Not functional 1: Functional

- **Selector 2: ITU-T (CCITT) superfine recommendation**

If this selector is set to "1," the equipment communicates in ITU-T (CCITT) recommended superfine mode (15.4 lines/mm). If it is set to "0," it communicates in native superfine mode.

- **Selector 7: Max. document length limitation**

This selector is used to select the maximum length of a document to be sent.

- **Selector 8: Stop key pressed during reception**

If this selector is set to "1," pressing the **Stop** key can stop the current receiving operation. The received data will be lost.

WSW17 (Function setting 2)

Selector No.	Function	Setting and Specifications
1 2	Off-hook alarm	No. 1 2 0 0 : No alarm 0 1 : Always valid 1 X : Valid except when 'call reservation' is selected.
3 4	Not used.	
5	Calendar clock type	0: U.S.A. type 1: European type
6	Not used.	
7	Non-ring reception	0: OFF 1: ON
8	Not used.	

NOTE: Selector 4 is not applicable to those models having a 2-row LCD.

- **Selectors 1 and 2: Off-hook alarm**

These selectors activate or deactivate the alarm function which sounds an alarm when the communication is completed with the handset being off the hook.

- **Selector 5: Calendar clock type**

If this selector is set to "0" (USA), the MM/DD/YY hh:mm format applies; if it is set to "1" (Europe), the DD/MM/YY hh:mm format applies: DD is the day, MM is the month, YY is the last two digits of the year, hh is the hour, and mm is the minute.

- **Selector 7: Non-ring reception**

Setting this selector to "1" makes the equipment receive calls without ringer sound if the ring delay is set to 0.

WSW18 (Function setting 3)

Selector No.	Function	Setting and Specifications
1	Not used.	
2 3	Detection enabled time for CNG and no tone	No. 2 3 0 0 : 40 sec. 0 1 : 0 sec. (No detection) 1 0 : 5 sec. 1 1 : 80 sec.
4 5	Not used.	
6	Registration of station ID	0: Permitted 1: Prohibited
7 8	Tone sound monitoring	No. 7 8 0 X : No monitoring 1 0 : Up to phase B at the calling station only 1 1 : All transmission phases both at the calling and called stations

- **Selectors 2 and 3: Detection enabled time for CNG and no tone**

After the line is connected via the external telephone or by picking up the handset of the facsimile equipment, the equipment can detect a CNG signal or no tone for the time length specified by these selectors. The setting specified by these selectors becomes effective only when selector 8 of WSW20 is set to "1."

- **Selector 6: Registration of station ID**

Setting this selector to "0" permits the registration of station ID for Austrian and Czech versions.

- **Selectors 7 and 8: Tone sound monitoring**

These selectors set monitoring specifications of the tone sound inputted from the line.

WSW19 (Transmission speed setting)

Selector No.	Function	Setting and Specifications
1 3	First transmission speed choice for fallback	No. 1 2 3 No. 4 5 6 0 0 0 : 2,400 bps 0 0 1 : 4,800 bps 0 1 0 : 7,200 bps 0 1 1 : 9,600 bps 1 0 0 : 12,000 bps 1 0 1 : } 1 1 0 : } 14,400 bps 1 1 1 : }
4 6	Last transmission speed choice for fallback	
7	Not used.	
8	V. 17 mode	0: Permitted 1: Prohibited

- Selectors 1 through 6: First and last choices of transmission speed for fallback**

These selectors are used to set the MODEM speed range. With the first transmission speed choice specified by selectors 1 through 3, the equipment attempts to establish the transmission link via the MODEM. If the establishment fails, the equipment automatically steps down to the next lowest speed and attempts to establish the transmission link again. The equipment repeats this sequence while stepping down the transmission speed to the last choice specified by selectors 4 through 6.

If the MODEM always falls back to a low transmission speed (e.g., 4,800 bps), set the first transmission speed choice to the lower one (e.g., modify it from 12,000 bps to 7,200 bps) in order to deactivate the high-speed MODEM function and reduce the training time for shorter transmission time.

Generally, to save the transmission time, set the last transmission speed choice to a higher one.

WSW20 (Overseas communications mode setting)

Selector No.	Function	Setting and Specifications
1	EP* tone prefix	0: OFF 1: ON
2	Overseas communications mode (Reception)	0: 2100 Hz 1: 1100 Hz
3	Overseas communications mode (Transmission)	0: OFF 1: Ignores DIS once.
4 5	Min. time length from reception of CFR to start of transmission of video signals	No. 4 5
		0 0 : 100 ms
		0 1 : 200 ms
		1 0 : 300 ms
		1 1 : 400 ms
6 7	Not used.	
8	CNG detection on/off	0: OFF 1: ON

* EP: Echo protection

- **Selector 1: EP tone prefix**

Setting this selector to "1" makes the equipment transmit a 1700 Hz echo protection (EP) tone immediately preceding training in V.29 modulation system to prevent omission of training signals.

Prefixing an EP tone is effective when the equipment fails to transmit at the V.29 modem speed and always has to fall back to 4800 bps transmission.

- **Selectors 2 and 3: Overseas communications mode**

These selectors should be used if the facsimile equipment malfunctions in overseas communications. According to the communications error state, select the signal specifications.

Setting selector 2 to "1" allows the equipment to use 1100 Hz CED signal instead of 2100 Hz in receiving operation. This prevents malfunctions resulting from echoes, since the 1100 Hz signal does not disable the echo suppressor (ES) while the 2100 Hz signal does.

Setting selector 3 to "1" allows the equipment to ignore a DIS signal sent from the called station once in sending operation. This operation suppresses echoes since the first DIS signal immediately follows a 2100 Hz CED (which disables the ES) so that it is likely to be affected by echoes in the disabled ES state. However, such a disabled ES state will be removed soon so that the second and the following DIS signals are not susceptible to data distortion due to echoes. Note that some models when called may cause error by receiving a self-outputted DIS.

- **Selectors 8: CNG detection on/off**

If this selector is set to "1," the equipment detects a CNG signal according to the condition preset by selectors 2 and 3 of WSW18 after a line is connected. If it is set to "0," the equipment detects a CNG signal as long as the line is connected.

WSW21 (TAD setting 1)

Selector No.	Function	Setting and Specifications
1 7	Not used.	
8	Erasure of message stored in the memory after the message transfer	0: Yes 1: No

- **Selector 8: Erasure of message stored in the memory after the message transfer**

Setting this selector to "0" will erase the message recorded in the memory after the document retrieval feature transfers the message.

WSW22 (ECM and copy resolution setting)

Selector No.	Function	Setting and Specifications
1	ECM* in sending	0: ON 1: OFF
2	ECM* in receiving	0: ON 1: OFF
3	Call Waiting Caller ID	0: ON 1: OFF
4	Not used.	
5 8	Acceptable TCF bit error rate (%) (Only at 4800 bps)	0: 0% 1: 8% 0: 0% 1: 4% 0: 0% 1: 2% 0: 0% 1: 1%

* ECM: Error correction mode

NOTE: Selector 3 is applicable to the American versions only.

NOTE: Selectors 5 through 8 are applicable to the Chinese, Taiwanese and Asian versions only.

- **Selector 3: Call Waiting Caller ID**

Setting this selector to "0" allows the user to decide whether or not to interrupt the current call when a new call comes in. If Call Waiting Caller ID service is available in the area and the user subscribes to it, he/she can see information about his/her incoming call on the LCD.

- **Selectors 5 through 8: Acceptable TCF bit error rate (%)**

Setting two or more selectors to "1" produces addition of percent assigned to each selector. If you set selectors 7 and 8 to "1," the acceptable TCF bit error rate will be 3%.

WSW23 (Communications setting)

Selector No.	Function	Setting and Specifications
1	Starting point of training check (TCF)	0: From the head of a series of zeros 1: From any arbitrary point
2 3	Allowable training error rate	No. 2 3 0 0 : 0% 0 1 : 0.5% 1 0 : 1% 1 1 : 2%
4 5		No. 4 5 0 0 : 16% 0 1 : 14% 1 0 : 10% 1 1 : 8%
6 7	Not used.	
8	Limitation of attenuation level	0: Yes 1: No

NOTE: Selector 8 is not applicable to the French versions.

- **Selector 1: Starting point of training check (TCF)**

At the training phase of receiving operation, the called station detects for 1.0 second a training check (TCF) command, a series of zeros which is sent from the calling station for 1.5 seconds to verify training and give the first indication of the acceptability of the line.

This selector sets the starting point from which the called station should start counting those zeros. If this selector is set to "0," the called station starts counting zeros 100 ms after the head of a series of zeros is detected.

If it is set to "1," the called station starts counting zeros upon detection of 10-ms successive zeros 50 ms after the head of a series of zeros is detected. In this case, if the detection of 10-ms successive zeros is too late, the data counting period will become less than 1.0 second, making the called station judge the line condition unacceptable.

- **Selectors 2 and 3: Allowable training error rate**

The called station checks a series of zeros gathered in training (as described in Selector 1) according to the allowable training error rate set by these selectors. If the called station judges the line condition to be accepted, it responds with CFR; if not, it responds with FTT.

- **Selectors 4 and 5: Decoding error rate for transmission of RTN**

The facsimile equipment checks the actual decoding errors and then transmits an RTN according to the decoding error rate (Number of lines containing an error per page ÷ Total number of lines per page) set by these selectors.

- **Selector 8: Limitation of attenuation level**

Setting this selector to "0" limits the transmitting level of the modem to 10 dB.

This setting has priority over the settings selected by WSW02 (selectors 5 through 8) and WSW13 (selectors 5 through 8).

WSW24 (TAD setting 2)

Selector No.	Function	Setting and Specifications
1 2	Not used.	
3 4	Time length from CML ON to start of pseudo ring backtone transmission	No. 3 4 0 0 : 4 sec. 0 1 : 3 sec. 1 0 : 2 sec. 1 1 : 1 sec.
5 8	Not used.	

- Selectors 3 and 4: Time length from CML ON to start of pseudo ring backtone transmission**

These selectors set the length of time from CML-ON up to the start of pseudo ring backtone transmission.

In those versions which have an OGM facility, the settings made by these selectors also apply to the length of time from CML-ON up to the start of OGM transmission.

WSW25 (TAD setting 3)

Selector No.	Function	Setting and Specifications
1 4	Not used.	
5 7	Pause between paging number and PIN	No. 5 6 7 0 0 0 : 2 sec. 0 0 1 : 4 sec. 0 1 0 : 6 sec. 0 1 1 : 8 sec. 1 0 0 : 10 sec. 1 0 1 : 12 sec. 1 1 0 : 14 sec. 1 1 1 : 16 sec.
8	Not used.	

NOTE: Selectors 5 through 7 are applicable only to the U.S.A. versions.

- Selectors 5 through 7: Pause between paging number and PIN**

These selectors set the pause time between a telephone number being paged and PIN (private identification number) for the paging feature.

WSW26 (Function setting 4)

Selector No.	Function	Setting and Specifications																									
1 2	Not used.																										
3	Dialing during document reading into the temporary memory in in-memory message transmission	0: Disabled 1: Enabled																									
4 5	No. of CNG cycles to be detected (when the line is connected via the external telephone except in the external TAD mode or via the built-in telephone)	<table> <tr> <td>No.4</td> <td>5</td> <td></td> <td></td> <td></td> </tr> <tr> <td>0</td> <td>0</td> <td>:</td> <td>0.5</td> <td>(A)</td> </tr> <tr> <td>0</td> <td>1</td> <td>:</td> <td>1</td> <td>(B)</td> </tr> <tr> <td>1</td> <td>0</td> <td>:</td> <td>1.5</td> <td>(C)</td> </tr> <tr> <td>1</td> <td>1</td> <td>:</td> <td>2</td> <td>(D)</td> </tr> </table>	No.4	5				0	0	:	0.5	(A)	0	1	:	1	(B)	1	0	:	1.5	(C)	1	1	:	2	(D)
No.4	5																										
0	0	:	0.5	(A)																							
0	1	:	1	(B)																							
1	0	:	1.5	(C)																							
1	1	:	2	(D)																							
6 8	Not used.																										

- **Selector 3: Dialing during document reading into the temporary memory in in-memory message transmission**

If this selector is set to "0," the facsimile equipment waits for document reading into the memory to complete and then starts dialing. This enables the equipment to list the total number of pages in the header of the facsimile message.

- **Selectors 4 and 5: No. of CNG cycles to be detected**

The equipment interprets a CNG as an effective signal if it detects a CNG signal by the number of cycles specified by these selectors when the line is connected via the external telephone except in the external TAD mode or via the built-in telephone.

WSW27 (Function setting 5)

Selector No.	Function	Setting and Specifications
1	Not used.	
2	Ringer OFF setting	0: Yes 1: No
3	Not used.	
4	Detection of distinctive ringing pattern	0: Yes 1: No
5 8	Not used.	

NOTE: Selector 4 is applicable only to the U.S.A. versions.

- **Selector 2: Ringer OFF setting**

This selector determines whether or not the ringer can be set to OFF.

- **Selector 4: Detection of distinctive ringing pattern**

If this selector is set to "1," the equipment detects only the number of rings; if it is set to "0," the equipment detects the number of rings and the ringing time length to compare the detected ringing pattern with the registered distinctive one.

WSW28 (Function setting 6)

Selector No.	Function	Setting and Specifications
1 3	Transmission level of DTMF high-band frequency signal	No. 1 2 3 0 0 0 : 0 dB 0 0 1 : +1 dB 0 1 0 : +2 dB 0 1 1 : +3 dB 1 0 0 : 0 dB 1 0 1 : -1 dB 1 1 0 : -2 dB 1 1 1 : -3 dB
4 6	Transmission level of DTMF low-band frequency signal	No. 4 5 6 0 0 0 : 0 dB 0 0 1 : +1 dB 0 1 0 : +2 dB 0 1 1 : +3 dB 1 0 0 : 0 dB 1 0 1 : -1 dB 1 1 0 : -2 dB 1 1 1 : -3 dB
7 8	Not used.	

- **Selectors 1 through 6: Transmission level of DTMF high-/low-band frequency signal**

These selectors are intended for the manufacturer who tests the equipment for the Standard. Never access them.

WSW29 (Function setting 7)

Selector No.	Function	Setting and Specifications
1 6	Not used.	
7	Impedance switching control in pulse dialing	0: OFF 1: ON
8	Prompt beep when the memory area for the activity report becomes full	0: No 1: Yes

NOTE: Selectors 7 and 8 are applicable only to the European versions.

- **Selector 8: Prompt beep for activity report**

This selector determines whether or not the equipment will beep if the memory area for the activity report becomes full, for prompting you to print out the report. (Printing it out will clear the memory area.)

WSW30

Selector No.	Function	Setting and Specifications
1 8	Not used.	

WSW31 (Function setting 9)

Selector No.	Function	Setting and Specifications
1	Not used.	
2	Default reduction rate for failure of automatic reduction during recording	0: 100% 1: 70%
3	Not used.	
4	Ink empty sensor	0: Yes 1: No
5	Minimum short-OFF duration in distinctive ringing	0: 130 ms 1: 90 ms
6 8	Not used.	

NOTE: Selector 5 is applicable only to the U.S.A. versions.

- **Selector 2: Default reduction rate for failure of automatic reduction during recording**

This selector sets the default reduction rate to be applied if the automatic reduction function fails to record one-page data sent from the calling station in a single page of the current recording paper.

If it is set to "0," the equipment records one-page data at full size (100%) without reduction; if it is set to "1," the equipment records it at 70% size.

- **Selector 5 Minimum short-OFF duration in distinctive ringing**

The ringer pattern consists of short and long rings, e.g., short-short-long rings. This selector sets the minimum OFF duration following a short ring in order to avoid missing ringer tones in distinctive ringing.

If this selector is set to "1," when the short-OFF duration is a minimum of 90 ms long, then the equipment will interpret the short-OFF as OFF.

WSW32 (Function setting 10)

Selector No.	Function	Setting and Specifications
1 4	Not used.	
5 6	Default resolution	No. 5 6 0 0 : Standard 0 1 : Fine 1 0 : Super fine 1 1 : Photo
7 8	Default contrast	No. 7 8 0 X : Automatic 1 0 : Super light 1 1 : Super dark

- **Selectors 5 and 6: Default resolution**

These selectors set the default resolution which applies when the equipment is turned on or completes a transaction.

- **Selectors 7 and 8: Default contrast**

These selectors set the default contrast which applies when the equipment is turned on or completes a transaction.

WSW33 (Function setting 11)

Selector No.	Function	Setting and Specifications
1 3	Not used.	
4 5	FAX receiving speed to be kept within the transmission speed limit to the PC	No. 4 5 0 0 : 14,400 bps 0 1 : 12,000 bps 1 0 : 9,600 bps 1 1 : 7,200 bps
6	Report output of polled transmission requests	0: Yes 1: No
7 8	Not used.	

- **Selectors 4 and 5: FAX receiving speed to be kept within the transmission speed limit to the PC**

To transmit FAX data being received from other facsimile equipment to the connected PC, you may need to keep the FAX receiving speed within the transmission speed limit to the PC. In an initial negotiation sequence for transmission, the equipment responds to the calling station with the allowable FAX receiving speed specified by these selectors.

WSW34 (Function setting 12)

Selector No.	Function	Setting and Specifications
1 3	Not used.	
4 5	No. of CNG cycles to be detected (when the line is connected via the external telephone in the external TAD mode or via the facsimile equipment in F/T mode)	No.4 5 0 0 : 0.5 (A) 0 1 : 1 (B) 1 0 : 1.5 (C) 1 1 : 2 (D)
6 7	Number of DTMF tone signals for inhibiting the detection of CNG during external TAD operation	No.6 7 0 0 : 3 0 1 : 2 1 0 : 1 1 1 : OFF
8	Not used.	

● **Selectors 4 and 5: No. of CNG cycles to be detected**

The equipment interprets a CNG as an effective signal if it detects a CNG signal by the number of cycles specified by these selectors when the line is connected via the external telephone in the external TAD mode or via the facsimile equipment in F/T mode.

● **Selectors 6 and 7: Number of DTMF tone signals for inhibiting the detection of CNG during external TAD operation**

If the equipment receives this specified number of DTMF tone signals during external TAD operation, it will not detect CNG afterwards.

If these selectors are set to "1, 1," the CNG detection will not be inhibited.

WSW35

Selector No.	Function	Setting and Specifications
1 8	Not used.	

WSW36 (Function setting 14)

Selector No.	Function	Setting and Specifications
1	ECP mode*	0: ON 1: OFF
2	Recovery from Inactive PC Interface	0: Disabled 1: Enabled
3	PC Power-off Recognition Time	0: Normal 1: Long
4	Not used.	
5	Escape from phase C	0: Yes 1: No
6 8	Lower limit of frequency to be ignored after detection of calling signals (Ci)	No. 6 7 8 0 0 0 : 0 (Not ignored) 0 0 1 : 4 (448 Hz) 0 1 0 : 8 (244 Hz) 0 1 1 : 12 (162 Hz) 1 0 0 : 16 (122 Hz) 1 0 1 : 20 (97 Hz) 1 1 0 : 24 (81 Hz) 1 1 1 : 28 (69 Hz)

*ECP (Enhanced Capabilities Port)

- **Selector 1: ECP mode**

The ECP mode enhances the normal bidirectional communications between the facsimile equipment and the connected PC for higher transmission speed.

- **Selector 2: Recovery from Inactive PC Interface**

If the facsimile equipment recognizes via the STB signal line that the connected PC is powered off, it will turn the PC interface outputs Low to protect the PC from hazards that could be caused by weak electric current accidentally flown from the equipment.

This selector determines whether the equipment should recover from the inactive PC interface to normal interfacing state upon receipt of data from the PC.

- **Selector 3: PC Power-off Recognition Time**

This selector sets the time length from when the equipment detects the PC powered off until it recognizes the detected state as power-off.

If selector 2 is set to "0," it is recommended that selector 3 be set to "1"; otherwise, the equipment may mistakenly detect PC powered off.

- **Selector 5: Escape from phase C**

This selector determines whether or not the equipment will escape from phase C when it detects an RTC (Return to Control) in non-ECM mode or an RCP (Return to Control Partial page) in ECM mode.

- **Selectors 6 through 8:** Lower limit of frequency to be ignored after detection of calling signals (Ci)

At the start of reception, if the equipment detects the frequency of calling signals (Ci) specified by selectors 1 through 4 of WSW14, it will start the ringer sounding. When doing so, the equipment may fail to detect the calling signals normally due to noises superimposed at the time of reception. To prevent it, use selectors 6 through 8 of WSW36.

If the equipment detects higher frequencies than the lower limit specified by these selectors, it will regard them as noise and interpret that detecting state as being normal, allowing the ringer to keep sounding (until the equipment starts automatic reception of FAX data if in the FAX mode or enters the TAD mode if set in the TEL mode, according to the preset number of ringers).

WSW37 (Function setting 15)

Selector No.	Function	Setting and Specifications
1	Printout of the stored image data of an unsent document onto an error report	0: No 1: Yes
2	Erasure of the stored image data of an unsent document at the time of the subsequent in-memory message transmission	0: No 1: Yes
3 8	Not used.	

- **Selector 1:** Printout of the stored image data of an unsent document onto an error report

This selector determines whether or not the 1st-page image data of a document will be printed out onto the error report if the document image data stored in the temporary memory cannot be transmitted normally.

- **Selector 2:** Erasure of the stored image data of an unsent document at the time of the subsequent in-memory message transmission

If in-memory message transmission fails repeatedly when selector 1 is set to "1," the temporary memory will be occupied with image data. Setting selector 2 to "1" will automatically erase the stored 1st-page image data of an unsent document at the time of the subsequent in-memory message transmission only when recording paper or toner runs out.

WSW38 to WSW41

Selector No.	Function	Setting and Specifications
1 8	Not used.	

WSW42 (Function setting 20)

Selector No.	Function	Setting and Specifications
1 3	Not used.	
4	JBIG coding	0: Disabled 1: Enabled
5 8	Not used.	

WSW43 (Function setting 21)

Selector No.	Function	Setting and Specifications
1	Not used.	
2 3	Wait time for PC-Fax reception (Class 2) and FPTS command transmission	No. 2 3 0 0 : 50 ms 0 1 : 100 ms 1 0 : 150 ms 1 1 : 0 ms
4 6	Not used.	
7	Automatic start of remote maintenance	0: No 1: Yes
8	JPEG coding	0: Disabled 1: Enabled

● **Selector 8: JPEG coding**

Setting this selector to "0" disables the equipment from sending/receiving JPEG color images and from receiving JPEG monochrome images.

WSW44 to WSW45

Selector No.	Function	Setting and Specifications
1 8	Not used.	

WSW46 (Monitor of power ON/OFF state and parallel port kept at high)

Selector No.	Function	Setting and Specifications
1 2	Monitoring the PC ON/OFF state	No. 1 2 0 0 : Disabled 0 1 : Monitor SELECT IN 1 0 : Monitor STROBE 1 1 : Monitor both SELECT IN and STROBE
3	Parallel port output pins kept at high level	0: Enabled 1: Disabled
4	Previous filtering parameters for white level compensation	0: Enabled 1: Disabled
5	Not used.	
6 8	Delay time at the start of scanning for making a single copy	No. 6 7 8 0 0 0 : No delay time 0 0 1 : 1 sec. 0 1 0 : 2 sec. 0 1 1 : 3 sec. 1 0 0 : 4 sec. 1 0 1 : 5 sec. 1 1 0 : 6 sec. 1 1 1 : 7 sec.

NOTE: Selector 4 is not applicable to models equipped with a flat-bed scanner.

- **Selectors 1 and 2: Monitoring the PC ON/OFF state**
For the related functions, refer to WSW36, selectors 2 and 3.
- **Selector 3: Parallel port output pins kept at high level**
Setting this selector to "0" will keep all parallel output pins of the facsimile equipment at high level. Use this setting if Resource Manager (bundled with MFC models) installed to WindowsNT running on the connected PC fails to monitor the power ON/OFF state of the facsimile equipment.
- **Selector 4: Previous filtering parameters for white level compensation**
At the start of scanning operation, the equipment usually initializes white and black level data stored in the EEPROM by scanning the while-level reference film attached to the document pressure bar. After long use of the equipment, however, the film may be contaminated with dust or dirt. Accordingly, incorrect white level data will be set up so that white vertical streaks will be brought on the scanning result.

Setting this selector to "0" (Enabled) will apply previously saved white level data instead of new incorrect compensation.
- **Selectors 6 through 8: Delay time at the start of scanning for making a single copy**
According to the setting made by these selectors, the MFC models may delay the scanning start timing to prevent the carriage drive vibration from affecting the document scanning. No setting change is required unless otherwise specified by Brother.

WSW47 (Paper handling for a feed error and delay of FAX line disconnection)

Selector No.	Function	Setting and Specifications
1	Handling paper at the occurrence of a paper feed timing error	0: Eject paper w/o print 1: Print on the current paper
2	Not used.	
3 4	Delay of FAX line disconnection when switching to the pseudo-ringing external telephone	No. 3 4 0 0 : 200 ms 0 1 : 400 ms 1 0 : 700 ms 1 1 : 1000 ms
5 8	Not used.	

NOTE: Selector 1 is applicable only to models equipped with a flat-bed scanner.

NOTE: Selectors 3 and 4 are applicable only to models supporting pseudo-ringing of a connected external telephone.

- **Selector 1: Handling paper at the occurrence of a paper feed timing error**

When feeding paper to the print start position, the equipment might cause a feed timing error so that the registration sensor goes ON signaling the presence of paper. This selector determines whether the equipment will print on the current paper or eject the current paper without printing and print on the next paper.

- **Selectors 3 and 4: Delay of FAX line disconnection when switching to the pseudo-ringing external telephone**

When the equipment receives a phone call, it can make the connected external telephone ring (so called pseudo-ringing). During pseudo-ringing, if you pick up the handset of the external telephone, the line might be disconnected due to cut-off of the line current.

To hold the line, the equipment may supply line current by making use of the pulse generator circuit that forms a parallel loop. This way the FAX line disconnection may be delayed. These selectors determine the delay period.

WSW48 to WSW50

Selector No.	Function	Setting and Specifications
1 8	Not used.	

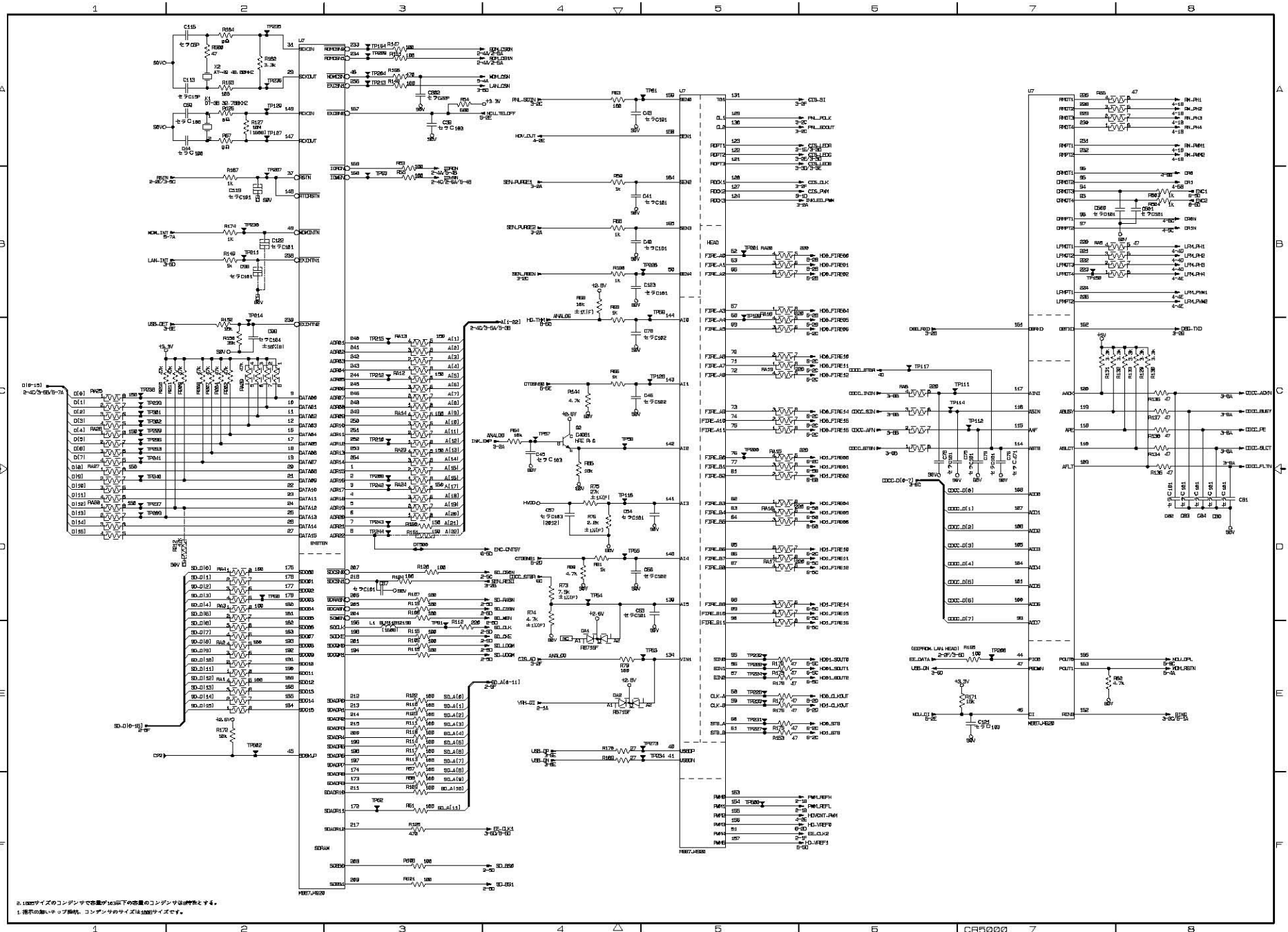

1. 1000サイズのコンデンサで容量が100以下の容量のコンデンサはすべてとする。
2. 指示の無いトップ面は、コンデンサのサイズは5000サイズです。

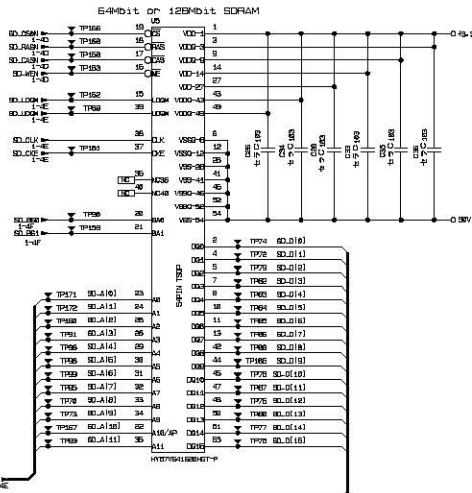
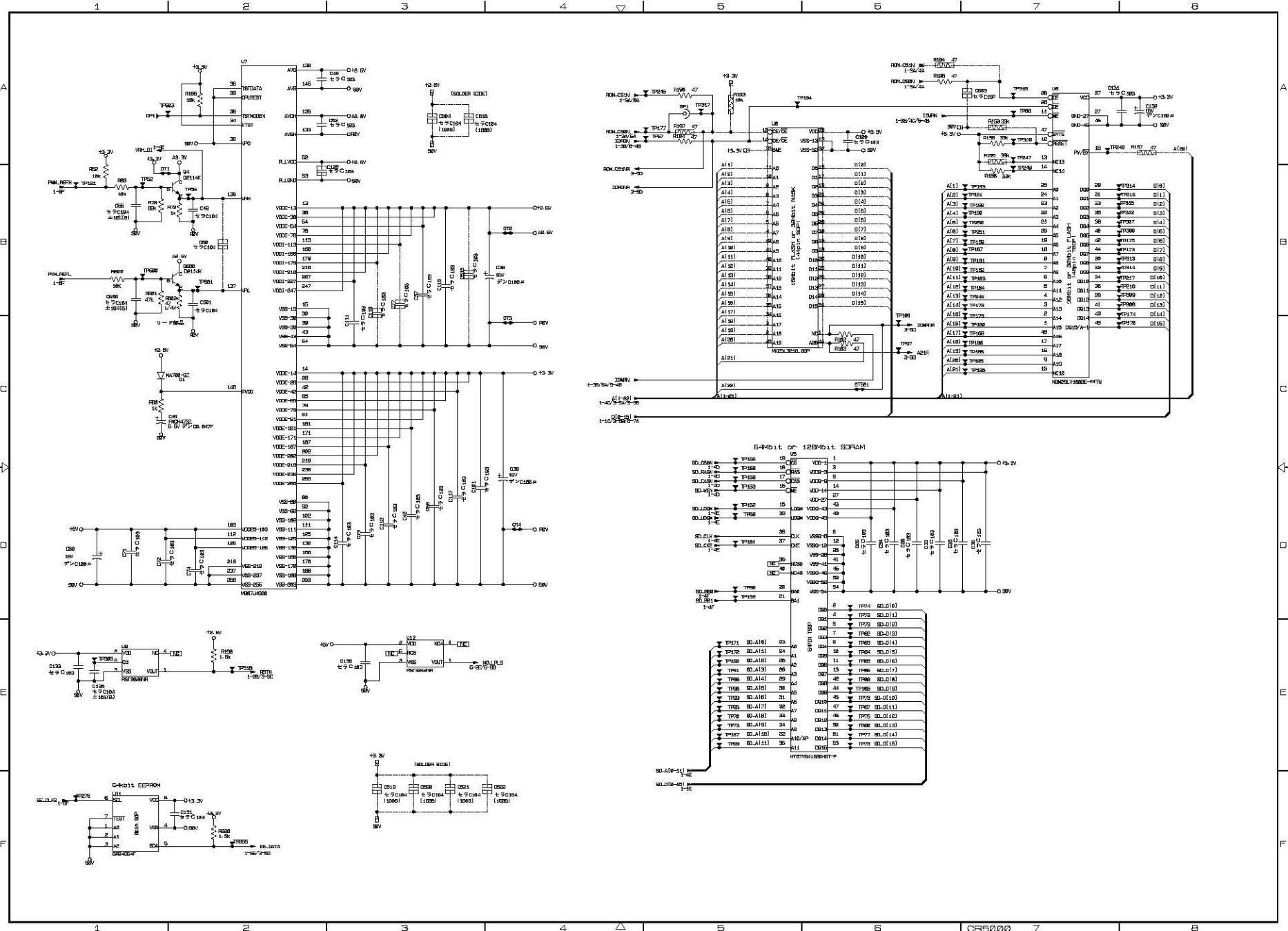

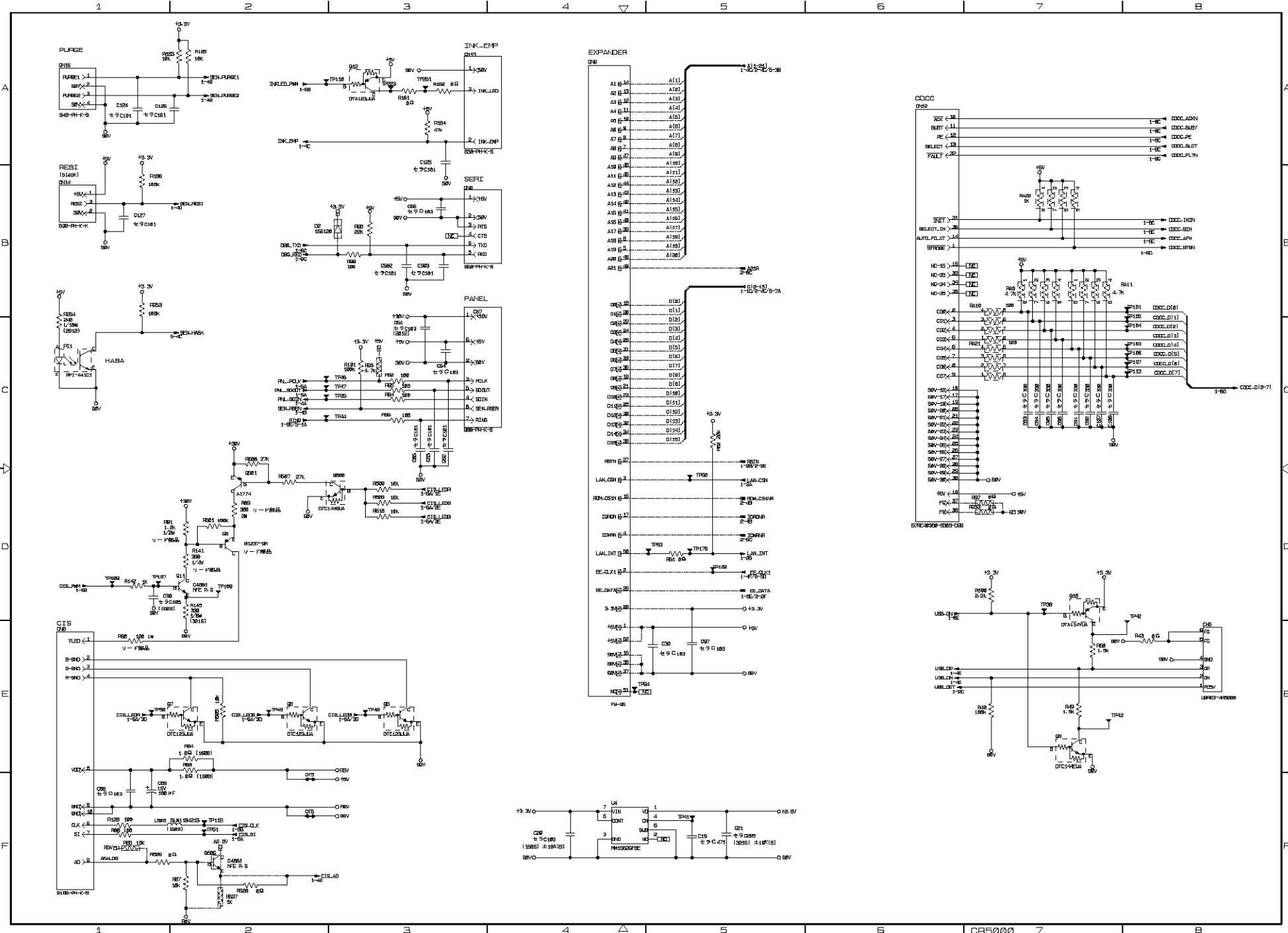

A. Main PCB (4/6)
(MFC3100C/MFC580)

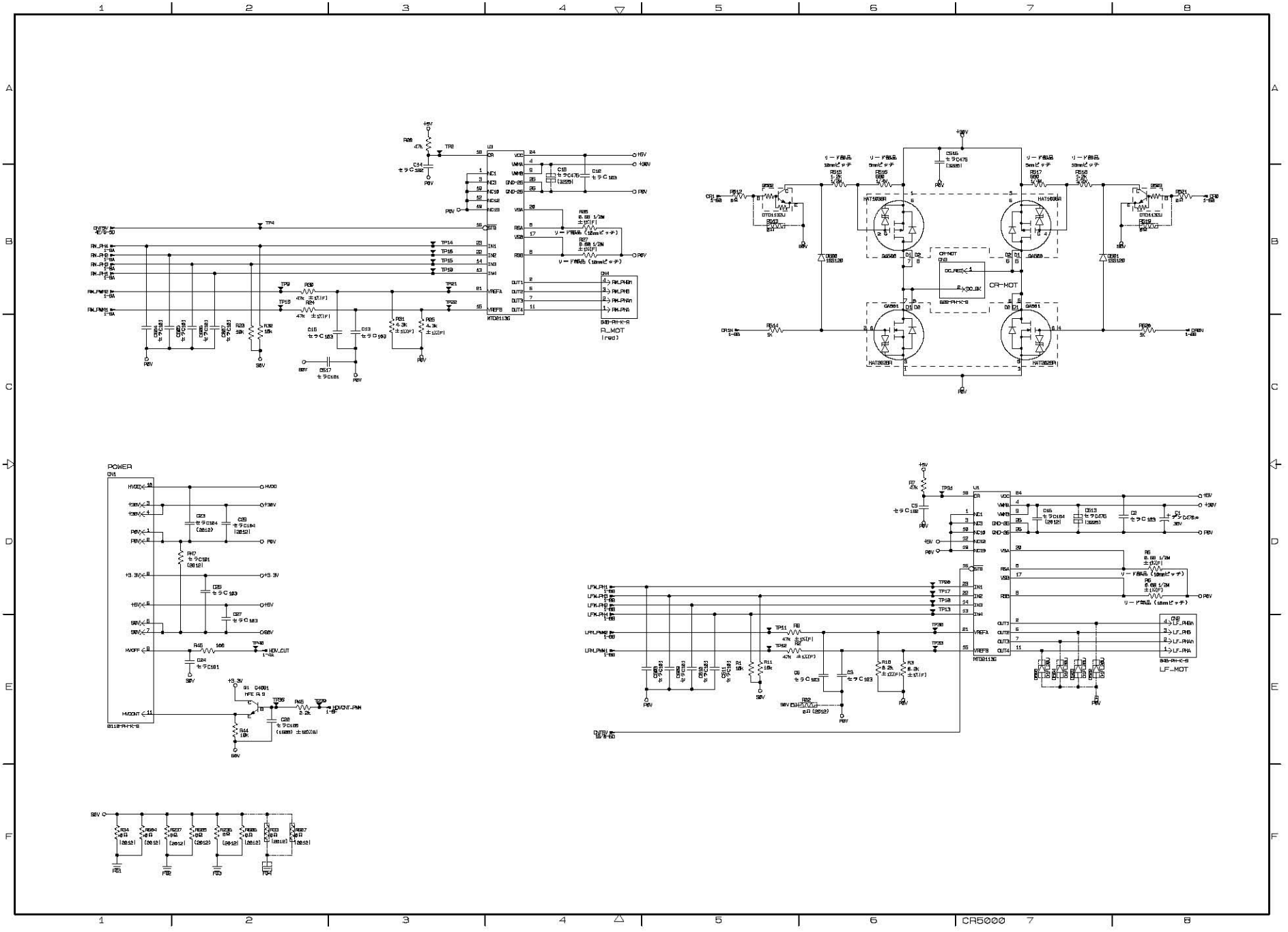

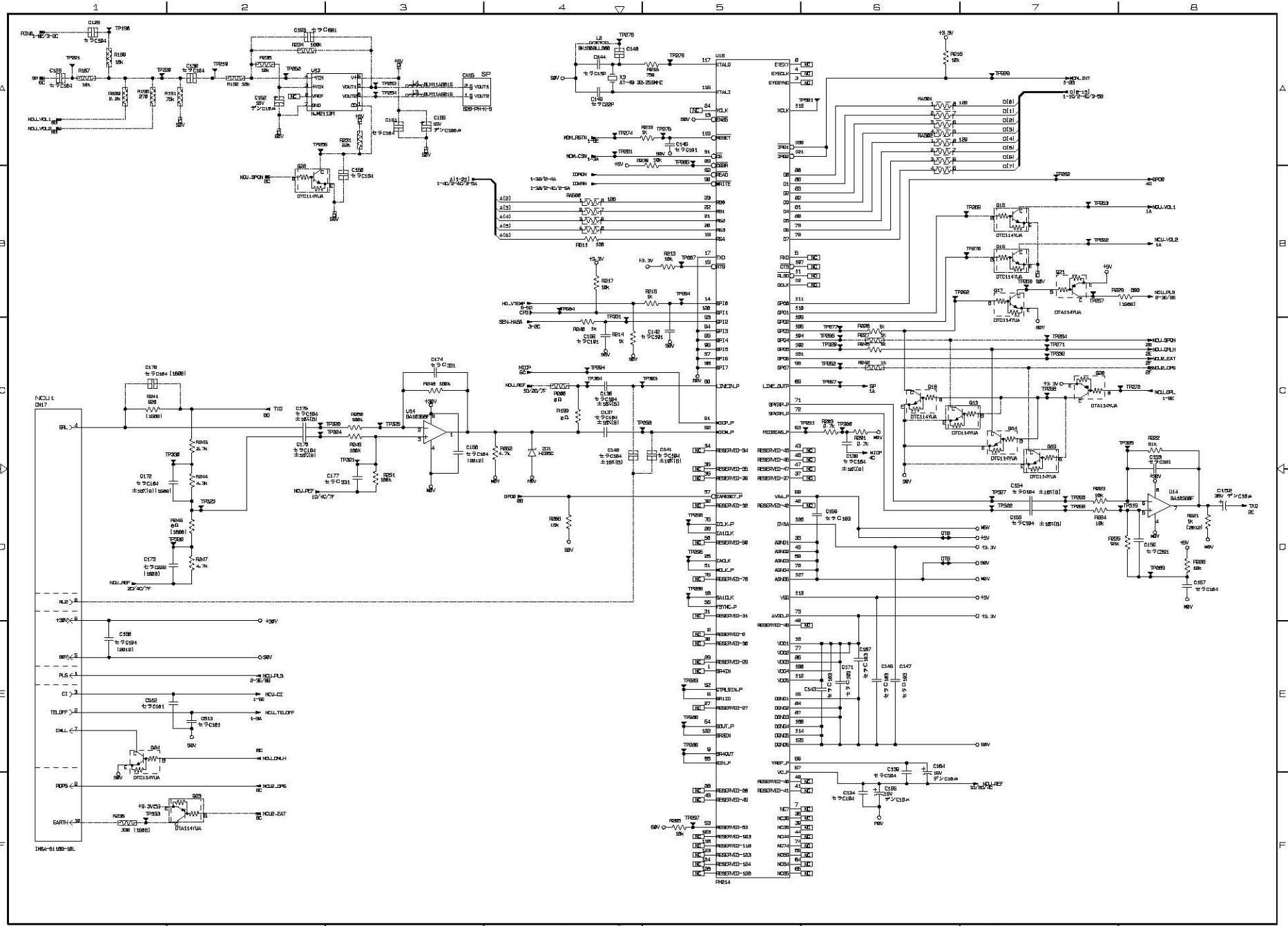

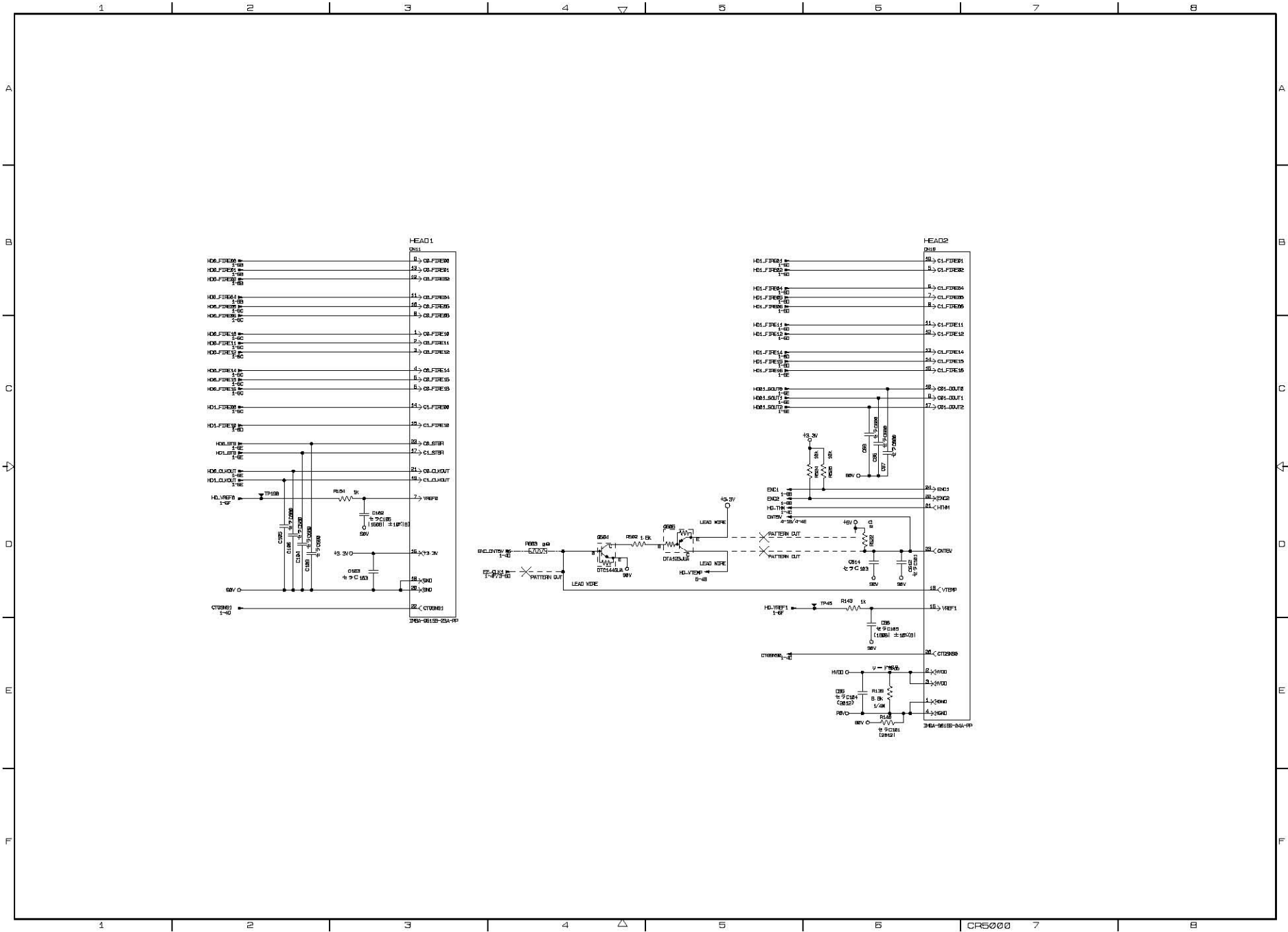

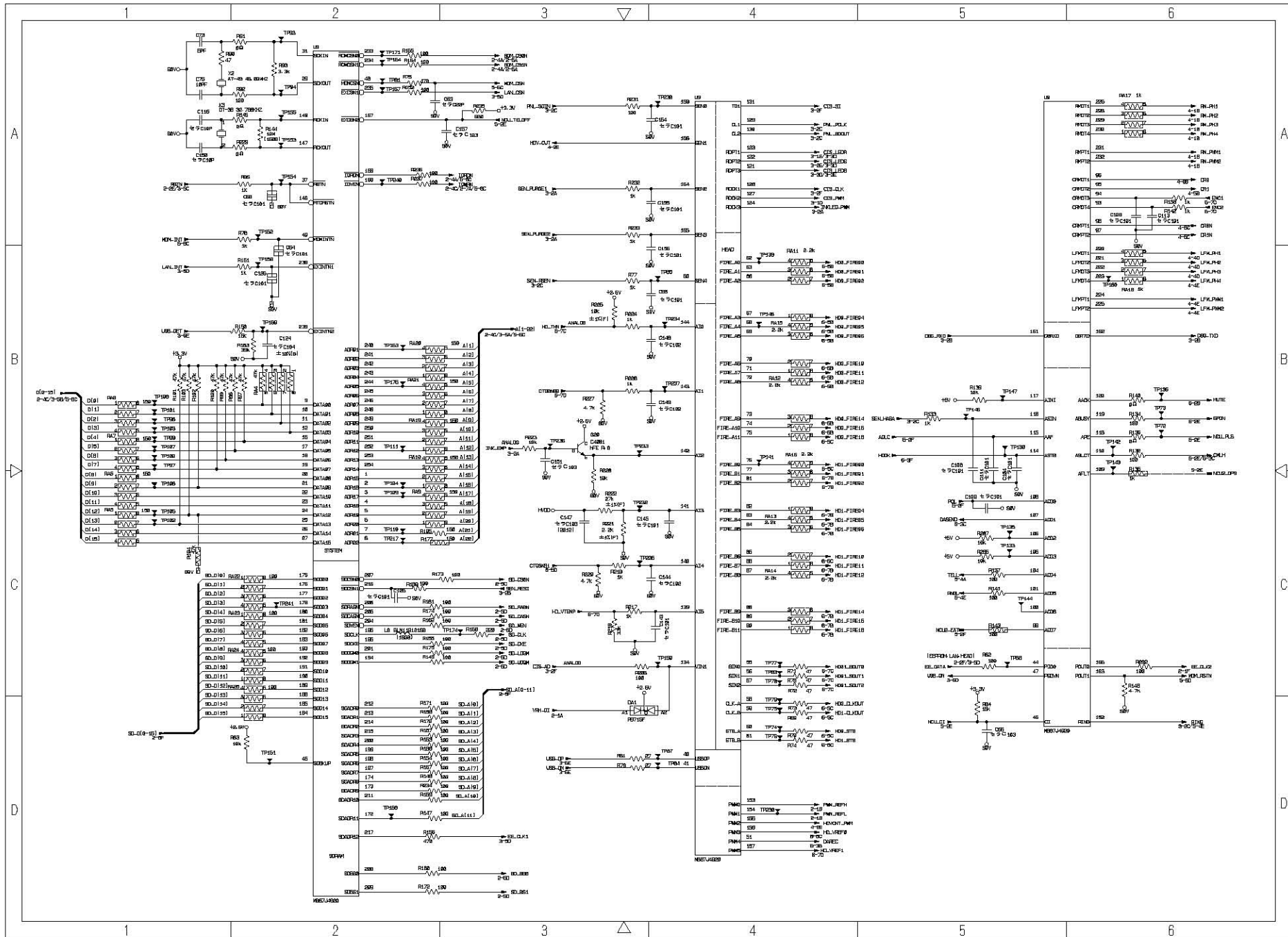

A

B

C

D

A

B

C

D

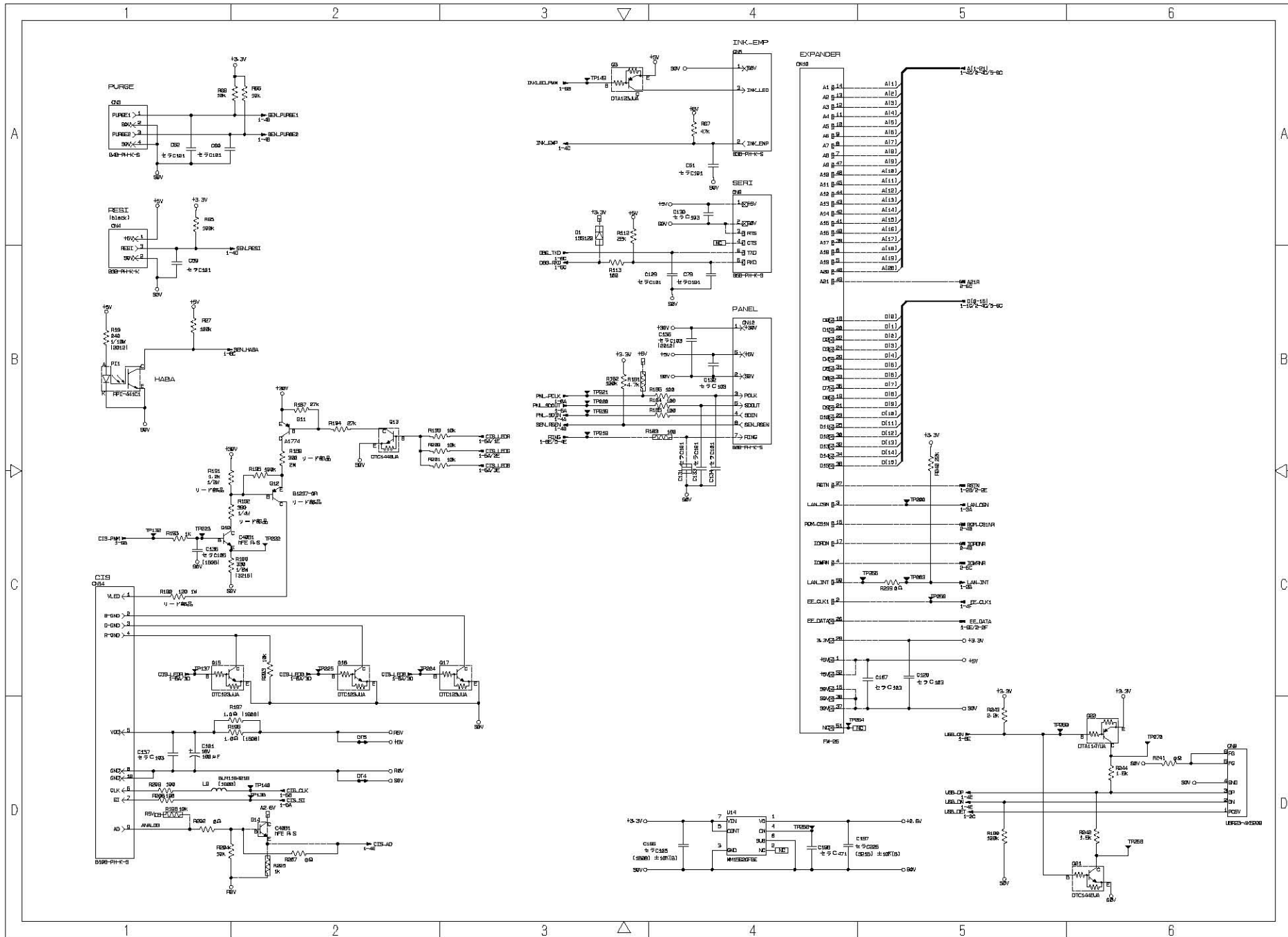

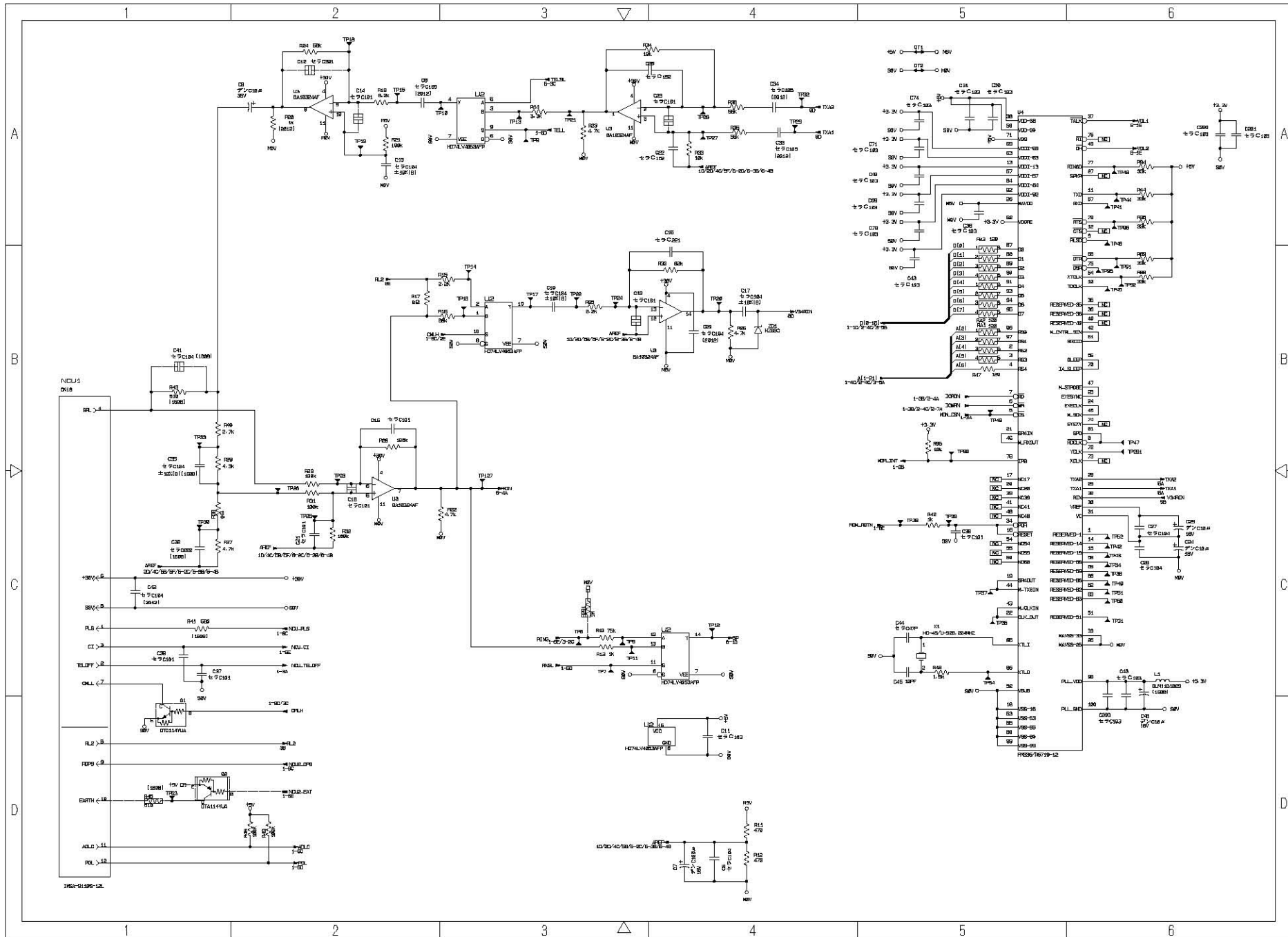

B. NCU PCB
(MFC3100C/MFC580)

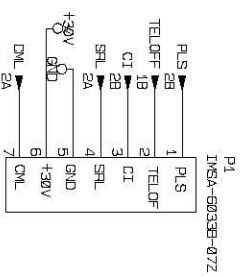
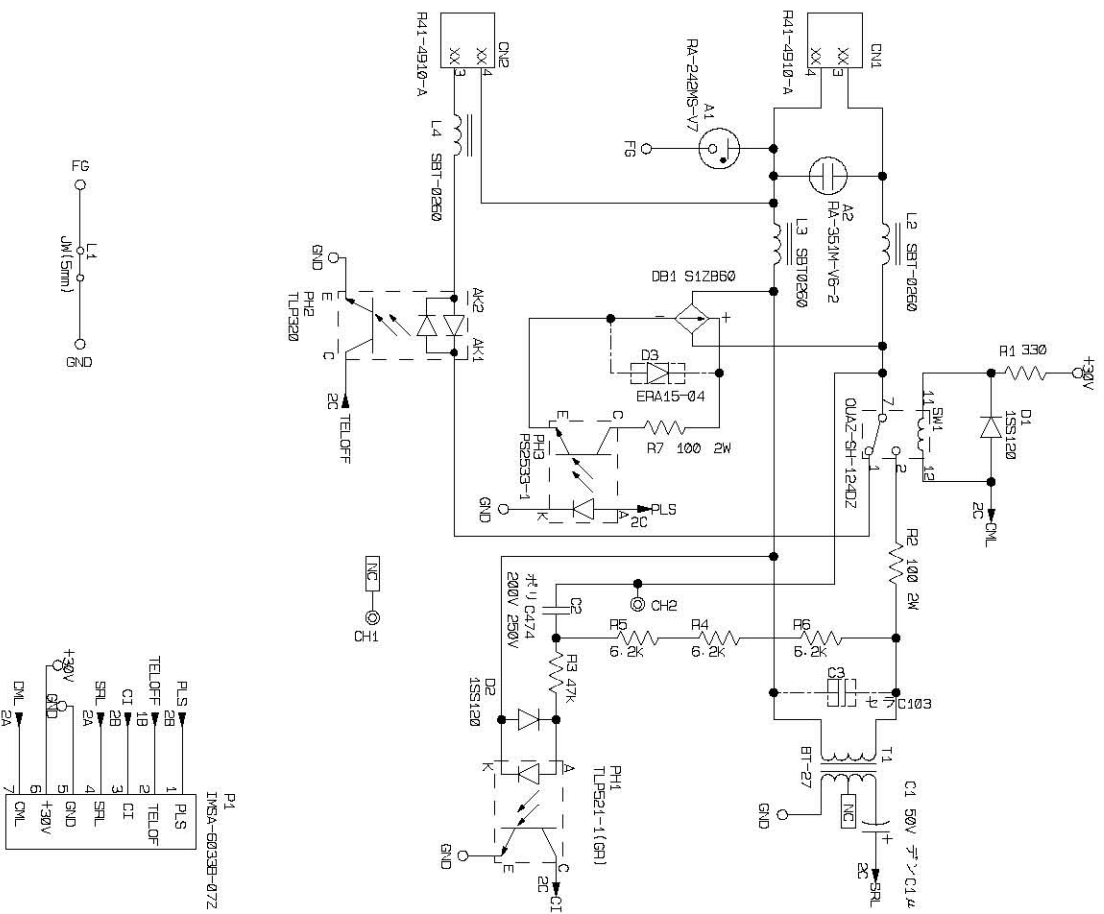

B. NCU PCB
(FAX1800C)

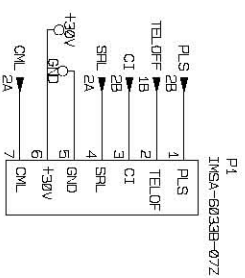
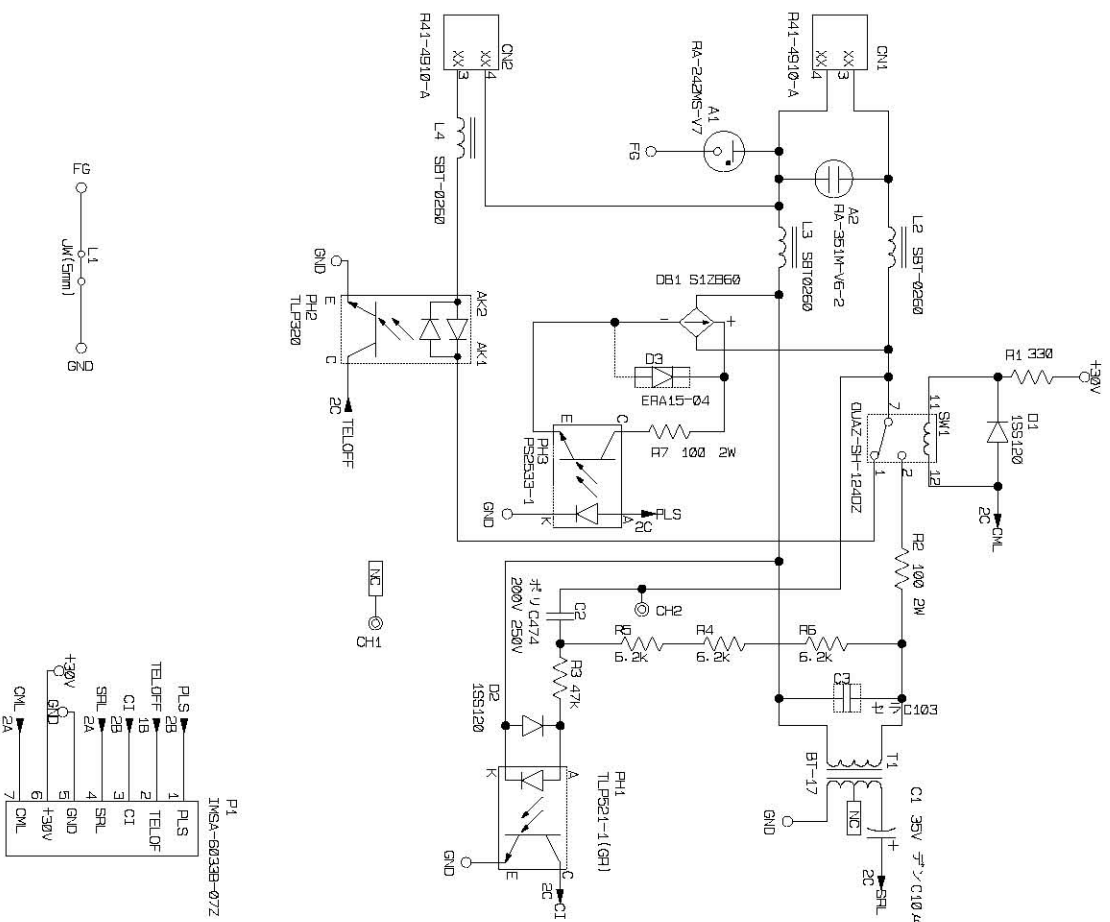

C. Control Panel PCB
(MFC3100C/MFC580)

指示の無いチップ部品のサイズは、全て1608とする。

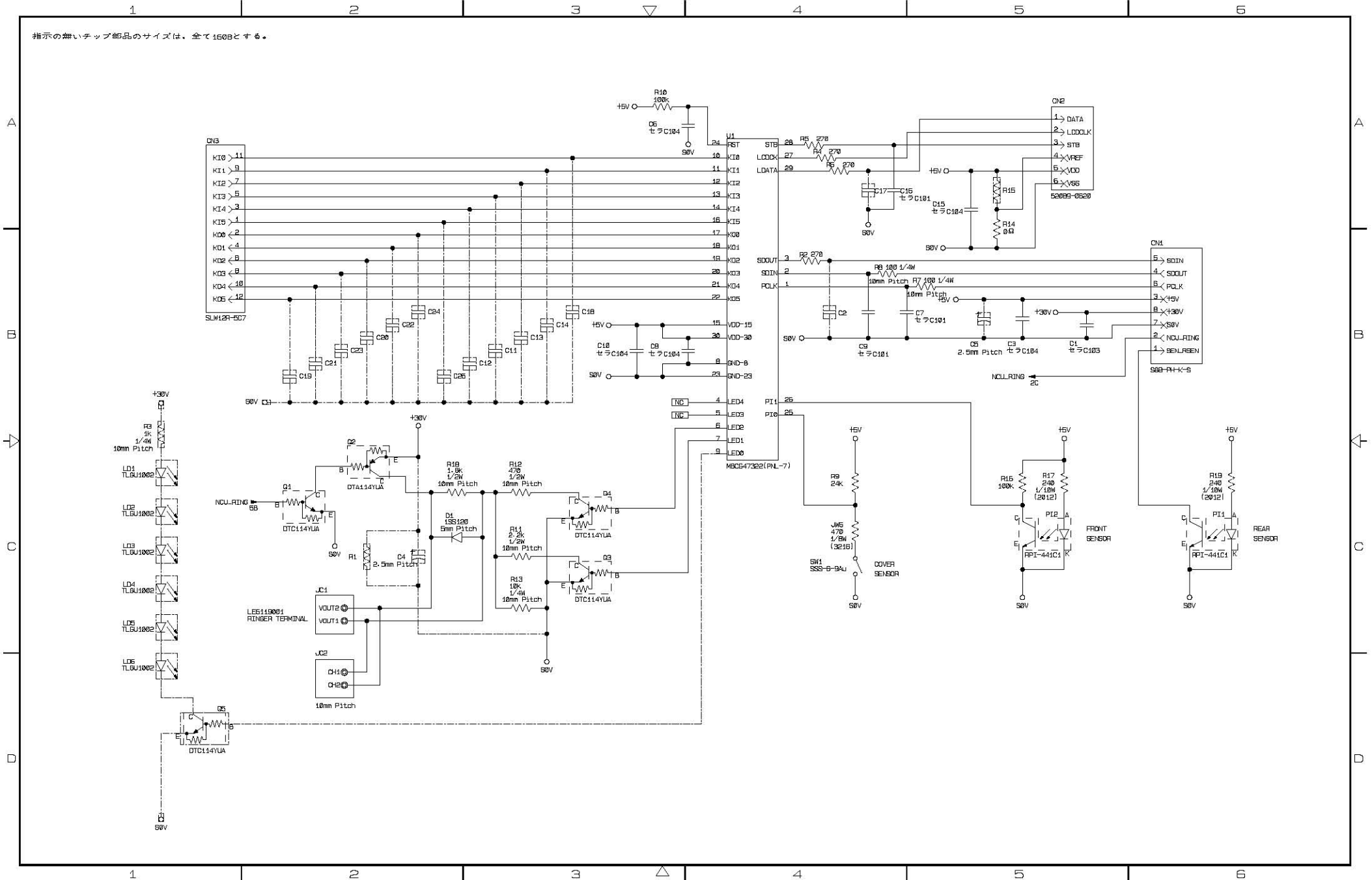

C. Control Panel PCB
(FAX1800C)

